

# External Payloads Proposer's Guide to the International Space Station

---

## International Space Station Program

### Baseline

August 2017

National Aeronautics and Space Administration  
International Space Station Program  
Johnson Space Center  
Houston, Texas

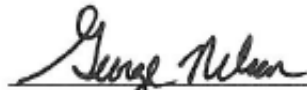


REVISION AND HISTORY

REV.	DESCRIPTION	PUB. DATE
-	Initial Release (Reference per SSCD 15774, EFF. 09-29-2017) Public access authorization obtained via the Document Availability Authorization Control Number: "40352"	10-02-17

**EXTERNAL PAYLOADS PROPOSER'S GUIDE TO  
THE INTERNATIONAL SPACE STATION  
PREFACE**

SSP 51071, External Payloads Proposer's Guide to the International Space Station is a Team Controlled document developed and maintained under the ISS Technology Science Research Office. Configuration control of this document is the responsibility of the ISS Technology Science Research Office and is under the control of the ISS Research Integration Office/OZ. Any changes or revisions must be approved by the ISS Research Integration Office/OZ. When a change is deemed appropriate, the document will be updated accordingly and the most up to date version will be made available to the users. The users should ensure that the most current version of the document is being used.

  
\_\_\_\_\_  
George Nelson  
Manager, ISS Technology Science Research Office  
National Aeronautics and Space Administration

9/21/17  
Date

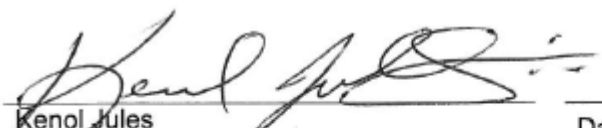
**EXTERNAL PAYLOADS PROPOSER'S GUIDE TO  
THE INTERNATIONAL SPACE STATION  
FORWARD**

The International Space Station (ISS) is a \$100 Billion science platform developed by NASA together with a host other nations to provide both an earth like laboratory environment as well as a space (vacuum) environment for scientists to perform their science. The ISS resides in a 51.6 degree inclined low earth orbit with an average altitude of 400 km. This unique location provides the ISS with a repetitive good earth and space viewing along with a good microgravity environment for conducting life, physical, Earth and space science research. The ISS, being a science platform, provides all of the resources that a science package (or instrument) would expect from an earth like laboratory such as power, data, cooling, commanding and other accommodation needs.

The ISS Program has a very thorough integration and interface process that an instrument package goes through once it has been selected to be operated on ISS. That integration and interface process is well documented through several ISS specific documents. This ISS Proposers Guide is not an integration and interface document and therefore should not be used as such. It is specifically designed to help the scientists in their early stage of proposal writing and submission to NASA Announcement of Opportunity (AO) and other government agencies in the field of Earth Science, Heliophysics and Astrophysics. As such, this Proposers Guide is strictly for ISS external Payloads.

The information contained in this Proposers Guide regarding the ISS resource capability, performance and environment has been reviewed by the ISS Research Integration Office (RIO), formerly known as the "Payloads Office", to ensure that it is accurate and reflect the current state of ISS. We strongly encourage the science community to make use of the ISS technical interface information contained in this Proposers Guide when developing their ISS instrument proposals, and, of course, the ISS Research Integration Office is always happy to help you if you need additional help using the information herein. Please do not hesitate to contact the RIO for any additional help.

Wishing you all the best with you proposals.

  
Date 09/21/17  
Kenol Jules  
ISS External Payloads Portfolio Manager  
NASA Johnson space Center  
Houston, TX 77058  
Phone: (281) 244-5516  
[Kenol.jules-1@nasa.gov](mailto:Kenol.jules-1@nasa.gov)

INTERNATIONAL SPACE STATION PROGRAM  
EXTERNAL PAYLOADS PROPOSER'S GUIDE  
TO THE INTERNATIONAL SPACE STATION  
CONCURRENCE  
AUGUST 2017

Prepared by:

Kenol Jules  
BOOK MANAGER

023  
ORG

  
SIGNATURE

09/21/17  
DATE

DQA:

Delegated Representative  
DOCUMENT MANAGEMENT

          
ORG

  
SIGNATURE

09-25-17  
DATE

## TABLE OF CONTENTS

PARAGRAPH		PAGE
1.0	INTRODUCTION .....	1-1
2.0	GENERAL INFORMATION FOR OPERATING ON ISS.....	2-1
2.1	HOW TO GET STARTED.....	2-1
2.2	ISS FEASIBILITY RESOURCE ACCOMMODATION ASSESSMENT PROCESS.....	2-2
2.3	WHAT YOU SHOULD KNOW .....	2-5
2.4	ORGANIZATIONAL ROLES/RESPONSIBILITIES .....	2-7
2.5	ROLES/RESPONSIBILITIES OF PAYLOAD PROVIDERS.....	2-8
3.0	COMMON ACCOMMODATIONS, RESOURCES, AND ENVIRONMENTS APPLICABLE TO ALL ISS EXTERNAL SITES .....	3-1
3.1	COMMON ACCOMMODATIONS AND RESOURCES APPLICABLE TO ALL ISS EXTERNAL SITES .....	3-4
3.1.1	ISS ROBOTICS OVERVIEW.....	3-4
3.1.2	WIRELESS CAPABILITY .....	3-11
3.1.3	ATTITUDE AND POINTING .....	3-13
3.1.4	ATTITUDE/ALTITUDE ADJUSTMENTS/CORRECTIONS.....	3-14
3.1.5	OVERVIEW OF ISS GUIDANCE, NAVIGATION, AND CONTROL (GN&C).....	3-16
3.2	ENVIRONMENTS APPLICABLE TO ALL ISS EXTERNAL SITES.....	3-25
3.2.1	MICROGRAVITY ENVIRONMENT .....	3-25
3.2.2	MICROMETEOROIDS/ORBITAL DEBRIS.....	3-27
3.2.3	MAGNETIC FIELD AND GRAVITATIONAL FIELD .....	3-29
3.2.4	ATOMIC OXYGEN .....	3-29
3.2.5	ON-ORBIT MINIMUM PRESSURE ENVIRONMENT.....	3-29
3.2.6	SPACE SINK TEMPERATURE .....	3-29
3.2.7	ELECTROMAGNETIC RADIATION (EMR).....	3-29
3.2.8	CONTAMINATION .....	3-29
3.2.9	IONOSPHERIC PLASMA EFFECTS AND SPACECRAFT CHARGING.....	3-34
4.0	EXTERNAL PAYLOAD SITES, ACCOMMODATIONS AND INTERFACES .....	4-1
4.1	INTEGRATED TRUSS ASSEMBLY/EXPRESS LOGISTICS CARRIER .....	4-3
4.1.1	INTRODUCTION .....	4-3
4.1.2	PHYSICAL ACCOMMODATIONS.....	4-3
4.1.3	ROBOTICS.....	4-7
4.1.4	THERMAL .....	4-8
4.1.5	POWER.....	4-10
4.1.6	COMMAND AND DATA HANDLING (C&DH).....	4-13
4.1.7	WIRELESS CAPABILITY .....	4-16
4.1.8	FIELD OF VIEW (FOV) .....	4-16
4.1.9	ELECTROMAGNETIC COMPATIBILITY/ELECTROMAGNETIC INTERFERENCE (EMC/EMI).....	4-20
4.2	JAPANESE EXPERIMENT MODULE-EXTERNAL FACILITY (JEM-EF) .....	4-21
4.2.1	PHYSICAL ACCOMMODATIONS.....	4-22
4.2.2	ROBOTICS.....	4-28
4.2.3	THERMAL .....	4-32

**SSP 51071  
Baseline**

4.2.3.1	PASSIVE THERMAL CONTROL SYSTEM (PTCS) INTERFACE .....	4-33
4.2.3.2	ACTIVE THERMAL CONTROL SYSTEM (ATCS) INTERFACE .....	4-33
4.2.4	POWER .....	4-39
4.2.5	COMMAND AND DATA HANDLING (C&DH).....	4-40
4.2.6	WIRELESS CAPABILITY .....	4-43
4.2.7	FIELD OF VIEW (FOV) .....	4-43
4.2.8	ELECTROMAGNETIC COMPATIBILITY/ELECTROMAGNETIC INTERFERENCE (EMC/EMI).....	4-51
4.3	COLUMBUS EXTERNAL PAYLOAD FACILITY (COLUMBUS-EPF) .....	4-51
4.3.1	PHYSICAL ACCOMMODATIONS.....	4-55
4.3.2	ROBOTICS (SSRMS/SPDM (DEXTRE)) .....	4-57
4.3.3	THERMAL .....	4-58
4.3.4	POWER (AND ELECTRICAL INTERFACES) .....	4-60
4.3.5	COMMAND AND DATA HANDLING (C&DH).....	4-63
4.3.6	WIRELESS CAPABILITY .....	4-65
4.3.7	FIELDS OF VIEW (FOV).....	4-65
4.3.8	ELECTROMAGNETIC COMPATIBILITY/ELECTROMAGNETIC INTERFERENCE (EMC/EMI).....	4-69
5.0	INTEGRATION AND OPERATIONS .....	5-1
5.1	INTEGRATION .....	5-1
5.1.1	INTEGRATION TEMPLATE (REFERENCE MILESTONES).....	5-1
5.1.2	ENGINEERING INTEGRATION (EI) PROCESS.....	5-4
5.1.2.1	ISS INTERFACE REQUIREMENTS (ITA USING THE ELC) .....	5-4
5.1.2.2	PD-DEVELOPED INTERFACE CONTROL DOCUMENTS.....	5-4
5.1.2.3	VERIFICATION .....	5-5
5.1.3	VERIFICATION INTERFACE TESTING (PART OF VERIFICATION PROCESS) .....	5-7
5.1.3.1	PHYSICAL INTEGRATION FACILITIES .....	5-9
5.1.3.2	JEM-EF ENGINEERING INTEGRATION PROCESS.....	5-9
5.1.3.3	COLUMBUS ATTACHED MODULE ENGINEERING INTEGRATION PROCESS.....	5-9
5.1.3.4	PAYLOAD-TO-LAUNCH VEHICLE/VISITING VEHICLE INTEGRATION .....	5-10
5.2	ISS OPERATIONS .....	5-10
5.2.1	OVERVIEW – ISS INTEGRATED MISSION ELEMENTS .....	5-10
5.2.2	PAYLOAD OPERATIONS INTEGRATION FUNCTION (POIF).....	5-11
5.2.3	MISSION OPERATIONS FUNCTIONS .....	5-13
5.2.4	PAYLOAD DEVELOPER REQUIREMENTS FOR OPERATIONS .....	5-15
5.2.5	DATA FLOW PLANNING .....	5-17
5.2.6	DATA DOWNLINK CAPABILITY .....	5-17
5.2.7	ADDITIONAL OPERATIONAL CONSIDERATIONS – RESOURCE SHARING .....	5-18
5.2.8	EVA OPERATIONS.....	5-19
5.2.9	CONTINGENCY EVA (AS REQUIRED).....	5-20
5.2.10	VISITING VEHICLE TIMELINE .....	5-20
5.2.11	OPERATIONS PRODUCT SUMMARY .....	5-20
5.2.12	END OF MISSION.....	5-21
6.0	LAUNCH VEHICLES AND VISITING VEHICLES SUPPORTING ISS EXTERNAL PAYLOADS .....	6-1

**SSP 51071  
Baseline**

6.1	OVERVIEW .....	6-1
6.1.1	FALCON 9 LAUNCH VEHICLE .....	6-2
6.1.2	DRAGON.....	6-4
6.2	LAUNCH AND INTEGRATION OVERVIEW.....	6-5
6.2.1	GENERAL LAUNCH MILESTONES.....	6-5
6.2.2	INTEGRATION SCHEDULE.....	6-6
6.2.3	MISSION PROFILE .....	6-6
6.2.4	IMPORTANT INFORMATION REGARDING DOCKING .....	6-8
6.3	CUSTOMER ACCOMMODATIONS .....	6-9
6.3.1	CARGO INTERFACE .....	6-9
6.3.2	POWER ACCOMMODATIONS .....	6-10
6.4	ANALYTICAL DATA PRODUCTS .....	6-11
6.5	SPACEX PROVIDED HARDWARE .....	6-11
7.0	FLIGHT AND GROUND SAFETY PROCESS .....	7-1
7.1	ROLES AND RESPONSIBILITIES .....	7-1
7.1.1	FLIGHT SAFETY.....	7-1
7.1.2	GROUND SAFETY.....	7-2
7.1.3	GROUND SAFETY AT INTERNATIONAL PARTNERS LAUNCH SITES .....	7-2
7.1.4	GROUND SAFETY AT NON-KSC U.S. LAUNCH SITES.....	7-2
7.2	FLIGHT SAFETY.....	7-2
7.3	GROUND SAFETY.....	7-3
7.4	SAFETY DATA PACKAGES .....	7-3
7.5	REQUIREMENTS.....	7-4
7.5.1	FLIGHT.....	7-4
7.5.2	GROUND.....	7-4
7.6	SAFETY IDENTIFICATION AND ANALYSIS .....	7-5
7.7	SUMMARY .....	7-6
8.0	ISS PROGRAM-PROVIDED HARDWARE.....	8-1
8.1	ISS-PROVIDED HARDWARE .....	8-1
8.2	ISS-PROVIDED SIMULATORS.....	8-1
8.3	INTERNATIONAL PARTNER FACILITIES.....	8-3
8.4	SUMMARY .....	8-3
9.0	PAYLOAD DEVELOPER-PROVIDED HARDWARE .....	9-1
10.0	ACRONYMS/ABBREVIATIONS .....	10-1
11.0	REFERENCE .....	11-1

**TABLE**

2.2-1	LIST OF ITEMS TYPICALLY REQUIRED TO COMPLETE THE ISS FEASIBILITY ASSESSMENT PROCESS.....	2-5
3.0-1	ON-ORBIT PAYLOAD RESOURCES .....	3-2
3.1.3-1	ISS ATTITUDE AND POINT ENVIRONMENT .....	3-13
3.1.3-2	GN&C PERFORMANCE REGARDING JITTER.....	3-14
3.1.5-1	TEA RANGES AND TYPICAL/PREDICTED PERFORMANCE.....	3-20
3.1.5-2	ATTITUDE AND RATE CONTROLLER REQUIREMENTS AND PREDICTED PERFORMANCE.....	3-21



**SSP 51071  
Baseline**

3.1.5-3	ISS POSITION AND ATTITUDE.....	3-22
3.1.5-4	BROADCAST TIME DESCRIPTION .....	3-23
3.1.5-5	TIME DISTRIBUTION OF ISS ATTITUDE AND EPHEMERIS STATE KNOWLEDGE AND CONTROL DATA .....	3-23
3.1.5-6	SPECIFICATIONS AND PREDICTIONS OF ATTITUDE RATES .....	3-24
3.2.1-1	ON-ORBIT RANDOM VIBRATION ENVIRONMENT .....	3-25
3.2.8-1	2015 CONTAMINATION FORECAST MAP SUMMARY .....	3-33
3.2.8-2	2016 CONTAMINATION FORECAST MAP SUMMARY .....	3-33
3.2.8-3	2017 CONTAMINATION FORECAST MAP SUMMARY .....	3-33
3.2.8-4	PREDICTED VERSUS MEASURED CONTAMINANT DEPOSITION ON MISSE 2 .....	3-34
4.0-1	ISS EXTERNAL CAPABILITIES COMPARISON .....	4-2
4.1.2-1	ALLOWABLE MASS AND C.G. LOCATION OF EXPA PAYLOADS.....	4-7
4.1.4-1	THERMAL ENVIRONMENT PARAMETERS .....	4-10
4.1.4-2	ISS FLIGHT ATTITUDES .....	4-10
4.1.5-1	EXPA POWER CONNECTORS .....	4-13
4.1.6-1	EXPA C&DH CONNECTORS .....	4-15
4.1.8-1	INDEX OF ELC FISH-EYE FOV IMAGES.....	4-16
4.2.1-1	DETAILED SUMMARY FOR EACH JEM-EF SITE .....	4-24
4.2.3-1	THERMAL-OPTICAL CHARACTERISTICS OF EXPERIMENT PAYLOAD OUTER SURFACES .....	4-33
4.2.3.2-1	ATCS FLUID INTERFACE COOLANT SUPPLY CHARACTERISTICS .....	4-35
4.2.3.2-2	DIFFERENTIAL PRESSURE AND SCHEMATIC.....	4-35
4.2.3.2-3	CLEANLINESS REQUIREMENTS FOR EXPERIMENT PAYLOAD FLUID SYSTEMS .....	4-36
4.2.3.2-4	ALLOWABLE LEAK FOR EXPERIMENT PAYLOAD .....	4-37
4.2.3.2-5	THERMAL ENVIRONMENT PARAMETERS .....	4-39
4.2.3.2-6	ISS FLIGHT ATTITUDES .....	4-39
4.2.7-1	SUMMARY OF THESE FISH-EYE FOV IMAGES.....	4-44
4.3.3-1	THERMAL ENVIRONMENT PARAMETERS .....	4-60
4.3.3-2	ISS FLIGHT ATTITUDES .....	4-60
4.3.7-1	INDEX OF COLUMBUS-EPF FISH-EYE FOV IMAGES .....	4-65
6.1.2-1	DRAGON OVERVIEW .....	6-5
6.2.1-1	MAJOR LAUNCH VEHICLE MILESTONES.....	6-6
8.1-1	ISS HARDWARE AVAILABLE AS GFE .....	8-1

**FIGURE**

3.0-1	EXTERNAL PAYLOAD ATTACHMENT LOCATIONS.....	3-2
3.0-2	ISS ORBIT.....	3-2
3.0-3	ISS C&DH ARCHITECTURE DIAGRAM.....	3-3
3.1.1-1	ISS DEXTRE .....	3-5
3.1.1-2	DEXTRE OTCM .....	3-6
3.1.1-3	DEXTRE INTERFACES .....	3-7
3.1.1-4	OTCM CLEARANCE ENVELOPE.....	3-7
3.1.1-5	RMCT CLEARANCE ENVELOPE .....	3-8
3.1.1-6	ISS SSRMS .....	3-9
3.1.1-7	SSRMS GRAPPLE FIXTURES .....	3-9

**SSP 51071  
Baseline**

3.1.1-8	ISS CANADA ARM 2 PICKS UP DEXTRE.....	3-10
3.1.9	DEXTRE REMOVES PAYLOAD FROM DRAGON .....	3-10
3.1.1-10	DEXTRE CARRIES PAYLOAD TO SITE .....	3-11
3.1.1-11	PAYLOAD IS INSTALLED INTO SITE .....	3-11
3.1.4-1A	ISS ALTITUDE PROFILE .....	3-15
3.1.4-1B	ISS REFERENCE TRAJECTORY ATTITUDE PROFILE .....	3-15
3.1.4-2	+XVV ORIENTATION OF ISS .....	3-16
3.1.5-1	ISS GN&C SYSTEM.....	3-17
3.1.5-2	LVLH REFERENCE .....	3-17
3.1.5-3	ISS DYNAMIC REFERENCES.....	3-18
3.1.5-4	NATURAL TEA RANGES.....	3-20
3.2.1-1	TYPICAL ELC MICROGRAVITY ENVIRONMENT.....	3-26
3.2.1-2	TYPICAL MICROGRAVITY ENVIRONMENT FOR JEM-EF .....	3-27
3.2.1-3	COLUMBUS MICROGRAVITY ENVIRONMENT .....	3-27
3.2.2-1	ARTIFICIAL SPACE DEBRIS ENVIRONMENT .....	3-28
3.2.8-1	PAYLOAD MAPPING SITES (ELCS 1-4).....	3-32
3.2.8-2	MISSE 8 CONFIGURATION ON ELC2 AND SAMPLE SURFACE ANALYSIS RESULTS ...	3-34
3.2.9-1	IONOSPHERE REFERENCE POTENTIAL-1.....	3-35
3.2.9-2	IONOSPHERE REFERENCE POTENTIAL-2.....	3-35
4.1.1-1	ELC LOCATIONS ON ISS.....	4-3
4.1.2-1	ELC LOCATION ON ISS .....	4-4
4.1.2-2	ELC LOCATION ON ISS .....	4-5
4.1.2-3	EXPA PAYLOAD ENVELOPE.....	4-5
4.1.2-4	GENERIC EXPA PAYLOAD COORDINATE SYSTEM .....	4-6
4.1.2-5	AFRAM AND PFRAM EXPENDED VIEW (NOTE: AFRAM ADAPTER PLATE AND THE AFRAM IS CONSIDERED A SINGLE UNIT).....	4-6
4.1.5-1	ISS ITA INTERFACES .....	4-11
4.1.5-2	ISS TO EXPA POWER BLOCK DIAGRAM.....	4-12
4.1.6-1	ISS TO EXPA C&DH BLOCK DIAGRAM .....	4-14
4.1.8-1	ELC-1 OUTBOARD EXPA PAYLOAD ACCOMMODATION FORWARD (RAM) AND NADIR .....	4-16
4.1.8-2	ELC-1 INBOARD EXPA PAYLOAD ACCOMMODATION AFT (WAKE) AND NADIR .....	4-17
4.1.8-3	ELC-2 OUTBOARD EXPA PAYLOAD ACCOMMODATION FORWARD (RAM) AND ZENITH .....	4-17
4.1.8-4	ELC-2 INBOARD EXPA PAYLOAD ACCOMMODATION FORWARD (RAM) AND ZENITH .....	4-18
4.1.8-5	ELC-3 OUTBOARD EXPA PAYLOAD ACCOMMODATION AFT (WAKE) AND ZENITH .....	4-18
4.1.8-6	ELC-3 INBOARD EXPA PAYLOAD ACCOMMODATION FORWARD (RAM) AND ZENITH FOVS.....	4-19
4.1.8-7	ELC-4 INBOARD EXPA PAYLOAD ACCOMMODATION FORWARD (RAM) AND NADIR FOVS.....	4-19
4.1.8-8	ELC-4 INBOARD EXPA PAYLOAD ACCOMMODATION AFT (WAKE) AND NADIR FOVS .....	4-20
4.2-1	ILLUSTRATED JEM-EF OVERVIEW .....	4-22
4.2-2	IMAGE OF JEM-EF FROM SPACE .....	4-22
4.2.1-1	ILLUSTRATED JEM-EF 10 LOCATIONS FOR EXPERIMENTAL PAYLOADS .....	4-23
4.2.1-2	JEM-EF TYPICAL CONFIGURATION.....	4-26

**SSP 51071  
Baseline**

4.2.1-3	PAYLOAD INTERFACE UNIT .....	4-27
4.2.1-4	STANDARD PAYLOAD ENVELOPE AND LOCATION OF THE REQUIRED GF .....	4-27
4.2.1-5	PIU STANDARD ENVELOPE AND GF .....	4-28
4.2.2-1	JEM-EF MA CONFIGURATION .....	4-29
4.2.2-2	SFA CONFIGURATION .....	4-30
4.2.2-3	ILLUSTRATION OF CLEARANCE FOR THE MA AND PAYLOAD GRAPPLING OPERATION .....	4-31
4.2.2-4	PIU DYNAMIC ENVELOPE .....	4-32
4.2.3.2-1	COOLANT PRESSURE DROP REQUIRED IN EXPERIMENT PAYLOAD .....	4-35
4.2.4-1	ELECTRIC POWER CONFIGURATION IN THE JPM .....	4-40
4.2.5-1	POWER AND DATA CONNECTIONS .....	4-41
4.2.7-1	JEM-EF EFU LOCATIONS AND ORIENTATIONS .....	4-44
4.2.7-2	JEM-EF PAYLOAD VOLUME LOCATIONS AND ORIENTATIONS .....	4-45
4.2.7-3	JEM-EF EFU PAYLOAD VOLUME LOCATIONS AND ORIENTATION .....	4-45
4.2.7-4	JEM-EF EFU1 PAYLOAD ACCOMMODATION FORWARD (RAM) AND NADIR) .....	4-46
4.2.7-5	JEM-EF EFU1 PAYLOAD ACCOMMODATION ZENITH .....	4-46
4.2.7-6	JEM-EF EFU2 PAYLOAD ACCOMMODATION NADIR AND ZENITH .....	4-46
4.2.7-7	JEM-EF EFU3 PAYLOAD ACCOMMODATION FORWARD (RAM) AND NADIR) .....	4-47
4.2.7-8	JEM-EF EFU3 PAYLOAD ACCOMMODATION ZENITH .....	4-47
4.2.7-9	JEM-EF EFU4 PAYLOAD ACCOMMODATION NADIR AND ZENITH .....	4-47
4.2.7-10	JEM-EF EFU5 PAYLOAD ACCOMMODATION FORWARD (RAM) AND NADIR) .....	4-48
4.2.7-11	JEM-EF EFU5 PAYLOAD ACCOMMODATION FORWARD ZENITH .....	4-48
4.2.7-12	JEM-EF EFU6 PAYLOAD ACCOMMODATION NADIR AND ZENITH .....	4-48
4.2.7-13	JEM-EF EFU8 PAYLOAD ACCOMMODATION NADIR AND ZENITH .....	4-49
4.2.7-14	JEM-EF EFU9 PAYLOAD ACCOMMODATION FORWARD (RAM) AND NADIR) .....	4-49
4.2.7-15	JEM-EF EFU9 PAYLOAD ACCOMMODATION ZENITH .....	4-50
4.2.7-16	JEM-EF EFU10 PAYLOAD ACCOMMODATION NADIR AND ZENITH .....	4-50
4.2.7-17	JEM-EF EFU11 PAYLOAD ACCOMMODATION FORWARD (RAM) AND ZENITH .....	4-50
4.2.7-18	JEM-EF EFU12 PAYLOAD ACCOMMODATION ZENITH .....	4-51
4.3-1	COLUMBUS EXTERNAL PAYLOAD SITES: SOZ, SOX, SDX, AND SDN .....	4-52
4.3-2 A AND B	COLUMBUS EXTERNAL PAYLOAD SITES .....	4-53
4.3-3	APM/ISS REFERENCE COORDINATE SYSTEM .....	4-53
4.3-4	APM COORDINATE SYSTEM .....	4-54
4.3-5	APM WITH EXTERNAL PAYLOADS AND OTCM LOCATIONS .....	4-54
4.3.1-1	CEPA ISOMETRIC VIEW AND COORDINATE SYSTEM .....	4-55
4.3.1-2	EXTERNAL PAYLOAD TO COLUMBUS ATTACHMENT .....	4-56
4.3.1-3	INTEGRATED EXTERNAL PAYLOAD ENVELOPE .....	4-57
4.3.4-1	INTEGRATED EXTERNAL PAYLOAD SYSTEM INTERFACES .....	4-61
4.3.4-2	ELECTRICAL CONNECTORS .....	4-62
4.3.4-3	EXTERNAL PAYLOAD POWER DISTRIBUTION .....	4-63
4.3.7-1	COLUMBUS-EPF OVERVIEW .....	4-66
4.3.7-2	COLUMBUS-EPF PAYLOAD DIMENSIONS .....	4-67
4.3.7-3	COLUMBUS SDN EXPA PAYLOAD ACCOMMODATION FORWARD (RAM) AND NADIR	4-67
4.3.7-4	COLUMBUS SDX EXPA PAYLOAD ACCOMMODATION FORWARD (RAM) AND NADIR	4-68

**SSP 51071**  
**Baseline**

4.3.7-5	COLUMBUS SOX EXPA PAYLOAD ACCOMMODATION FORWARD (RAM) AND ZENITH .....	4-68
4.3.7-6	COLUMBUS SOZ EXPA PAYLOAD ACCOMMODATION FORWARD (RAM) AND ZENITH .....	4-68
5.1.1-1	ISS INTEGRATION TEMPLATE .....	5-3
5.1.2.3-1	SUMMARY OF VERIFICATION PROCESS .....	5-6
5.1.3-1	TESTING FLOW .....	5-8
5.2-1	ISS OPERATIONS AND MANAGEMENT .....	5-10
5.2.1-1	TYPICAL COMMAND AND TELEMETRY PATH .....	5-11
5.2.2-1	ISS PAYLOAD OPERATIONS ORGANIZATIONAL INTERFACES .....	5-12
5.2.2-2	TYPICAL POIF TO PD-POC INTERFACE AND DATA FLOW .....	5-13
5.2.8-1	ISS U.S. PAST AND PREDICTED EVAS .....	5-19
5.2.10-1	VISITING VEHICLES .....	5-20
5.2.11-1	OPERATIONS PRODUCTS TIMELINE .....	5-21
6.1-1	SPACEX FALCON 9 .....	6-2
6.1.1-1	FALCON 9 LIFTOFF .....	6-3
6.1.1-2	DRAGON .....	6-4
6.3.1-1	DRAGON COMPARTMENTS .....	6-9
6.3.1-2	DRAGON MAJOR COMPONENTS .....	6-10
6.3.1-3	THREE FRAM-BASED UNPRESSURIZED CARGO ITEMS .....	6-10
8.2-1	PORTABLE TEST ENVIRONMENT FOR DEVELOPMENT AND TESTING OF ELC PAYLOADS .....	8-2
8.2-2	ELC SUITCASE SIMULATOR .....	8-2
8.2-3	ELC SIMULATOR .....	8-3
9.0-1	PD-PROVIDED HARDWARE INTERFACE PLANE .....	9-2

## 1.0 INTRODUCTION

The Earth Science External Payload Proposers Guide for the International Space Station (ISS) (the Guide) provides proposers that are new to the ISS world an overview of the capabilities, accommodations, and requirements for operating on the ISS. Proposers typically include Principal Investigators, Payload Developers (PD), Systems Engineers, and others who are instrumental in developing a new proposal. The Guide is intended as a one-stop shop, with a supporting documents list, for developing proposals for operating external payloads on the ISS, and provides an overarching view of the ISS.

The ISS Program provides an infrastructure capable of providing external payloads valuable short- to long-term access to space. The space station, the on-orbit crew, the launch and return vehicles, and the operation control centers all assist in supporting external payloads and their unique operations. The ISS is the only long-duration platform available in the relevant space environment with an integrated space systems architecture that can be used in this capacity.

External payload accommodations are provided at attach sites on the United States (U.S.)-provided Expedite the Processing of Experiments to the Space Station (ExPRESS) Logistics Carrier (ELC) on the Integrated Truss Assembly (ITA), the Japanese Experiment Module-Exposed Facility (JEM-EF) and the Columbus-External Payload Facility (Columbus-EPF).

The external attachment sites accommodate payload carriers on the multiple viewing sites, both zenith and nadir on the ITA sites, using the ELC. The JEM-EF, a back-porch-like attachment to the JEM pressurized module, accommodates multiple payloads, which may be serviced by the crew via the JEM dedicated robotic arm. The Columbus-EPF is another back-porch-like platform that can accommodate two zenith- and two nadir-looking payloads, using similar payload carrier platforms used on the truss sites. Each of these external accommodations are discussed in detail in subsequent sections of this document.

The Guide outlines the roles and responsibilities of several organizations with whom proposers will interface during the payload planning, development, integration, and operations processes. It provides a section dedicated to the “how to get started” process, having your payloads manifested for flight on the ISS, and whom to interface with within the NASA community. The Guide highlights the many products that proposers will either provide inputs to or develop for their own use and identifies services that are available from several NASA ISS Program Office organizations that proposers will use as part of the overall process for operating on the ISS. Finally, it lists several documents that the proposer may elect to review for further details in specific sections, and it provides a list of references that corresponds with the narrative portion of the Guide.

In addition, the Guide provides overviews of the payload physical and engineering integration processes, operations concepts and processes, an overview of both flight and ground safety requirements, and a document tree that provides names and links to

important ISS documents. The Guide highlights hardware that will be required for flying on specific ISS accommodations and hardware that are made available to the PD in simulating ISS interfaces.

This Guide is primarily directed at first-time External Payload proposers. The Guide is NOT a design-to document. The Guide provides a level of detail that should be sufficient in developing a proposal. However, numerous ISS design-to documents exist within the ISS system and this document provides web links to some of these documents that eventually will be required for flying on the ISS.



**Welcome to the world of the International Space Station!**

## 2.0 GENERAL INFORMATION FOR OPERATING ON ISS

### 2.1 HOW TO GET STARTED

The intent of the Proposer's Guide is to provide sufficient detail about the ISS accommodations and interfaces for you to formulate proposals properly, without having to delve deeply into the vast number of ISS payload documents. Examples of the Guide's technical content include: mass and volume allowances, power availability and limitations, data rates, platform stabilization rates, thermal conditions, electromagnetic compatibility (EMC)/electromagnetic interference (EMI) compatibility, observational geometry requirements, launch vibration constraints, etc. It also includes sections on integration, operations, safety, and a list of documents included as references.

The Guide is not a design-to document or a substitute for the vast amount of ISS payload accommodation and interface information that you will need to be familiar with to carry out detailed design, integration, test, and reviews if your proposal is selected.

During the proposal process, you will be required to provide an overview briefing to the ISS Research Integration Office (RIO), located at the Johnson Space Center (JSC), Houston, TX, containing your proposed payload concept. This briefing is important, as the ISS RIO will then conduct a feasibility assessment based on your inputs. The assessment ultimately determines the feasibility of safely conducting your proposed mission on the ISS, and the results of the assessment play a critical part of the proposal approval process. In addition, RIO will provide you specific information required for the feasibility assessment, the completion/submittal timetable, and any meeting or telecom attendance requirements. Subsequently, the ISS RIO will issue an assessment letter following internal review of your information. The assessment letter will address your specific accommodation needs, including any possible exceedances (e.g., on-orbit volume), and will state allowances. Finally, after the feasibility assessment is approved, your proposal must address management, risks, and costs in addition to meeting ISS technical and interface requirements. Details of the ISS Feasibility Resource Accommodation Assessment process is outlined in Paragraph 2.2, ISS Feasibility Resource Accommodation Assessment Process. The ISS RIO, and more specifically, the ISS NASA Science and Technology Office within the ISS RIO, will be your primary point of contact during both the proposal process, and following selection of your payload. For information and to schedule a payload concept briefing, please contact the Manager of that Office. If you are responding to an Announcement of Opportunity (AO), the AO will identify your ISS Program Office Point of Contact.

If selected, an ISS Payload Integration Manager (PIM) will be assigned to your payload by the ISS RIO to address the specifics of what you need following proposal selection. The ISS has many site-specific requirements to be aware of for more detailed design interface information. Two links available for ISS documentation are:

- [http://www.nasa.gov/mission\\_pages/station/research/ops/research\\_information.html#.U6sC9RCiV2B](http://www.nasa.gov/mission_pages/station/research/ops/research_information.html#.U6sC9RCiV2B)
- <https://iss-www.jsc.nasa.gov/nwo/apps/edms/web/> (account application required)

## 2.2 ISS FEASIBILITY RESOURCE ACCOMMODATION ASSESSMENT PROCESS

Since the ISS, as a science platform and is already designed and built, its technical interface requirements and resource accommodation capability are known. Therefore, instruments that are being proposed, designed and built to fly and operate on ISS need to meet a specific set of technical interface requirements and resource accommodation limits (e.g., mass, power, cooling flow rate, etc.). Because of the need to take all of these issues into consideration during the pre-proposal submission phase, all proposed ISS external payloads need to go through an ISS feasibility resource accommodation assessment to determine whether that proposed concept can be accommodated on ISS. This feasibility assessment must be performed before a proposal to fly and operate on ISS is submitted to NASA in response to a NASA AO that lists ISS as a science platform for that AO. The feasibility resource accommodation assessment is performed by the ISS RIO, located at the NASA JSC. The RIO is an office within the ISS Program Office. Upon the completion of the feasibility assessment, a feasibility accommodation assessment letter is issued to the proposal team, which needs to be submitted to NASA as part of the proposal package. Table 2.2-1, List of Items Typically Required to Complete the ISS Feasibility Assessment Process, should be completed and included in your proposal in the section dealing with ISS resource accommodations needed.

In performing the accommodation feasibility assessments, the ISS RIO examines whether the proposed instrument meets the standard interfaces or requires significant non-standard integration. Working with the proposer, RIO will evaluate the proposed dimensions and determine if the instrument is within the standard dimensions or exceeds those dimensions in one or more areas. If the proposed concept exceeds the standard ISS interfaces, RIO will provide an evaluation of how simple or hard it will be to accommodate those non-standard interfaces. The proposers will be made aware of any non-standard interfaces to determine if they can modify their design to stay within the known standard interfaces. Often, non-standard interfaces can be accommodated, but require additional work during the instrument ISS integration process if the instrument is selected to fly and operate on ISS.

### Nominal Data Required From Proposer Team to Perform the Assessment

To perform the feasibility assessment, the proposal team needs to provide specific required information to RIO. Below is an example data set that is required from the proposal teams:

- Payload Upmass (Includes both instrument and ISS Interface Hardware)
- Volumetric Dimensions (both static and dynamic envelopes)
- Power consumption (includes peak power, average power, and survival)
- Data rates (includes average and maximum and any data latency requirements)
- Pointing/viewing needs
- Lifetime required on orbit
- Instrument readiness date (date payload is ready to fly to ISS)
- Return plan



Since the assessment involves a good understanding of the proposed concept being reviewed, instead of providing just the data set as noted above, presentation material (e.g., a PowerPoint® presentation) is preferred as the concept architecture and deployment concept must be understood by the RIO evaluator. Therefore, a presentation is requested from the proposal team, which covers, at a minimum, the following:

1. Payload science objectives, instrument requirements, design and integrated testing, ground operation concept, on-orbit operation concept and commanding approach, ground processing, payload launch vehicle integration and launch, robotic transfer (on-orbit installation--will the payload be built/assembled on-orbit?, removal and disposal), data handling and power system, static volume envelope and on-orbit dynamic volume versus ISS payload envelope requirement, clearly identified ISS interface requirement violation, graphics of the design concept to show how it will be mounted on an ELC Flight Releasable Attach Mechanism (FRAM) or JEM-EF, any envelope dimension violation and potential impact on both launch vehicle integration and on-orbit operations, a list of any instrument-specific constraints levied on ISS, on-orbit life requirement, mass, and whether any active cooling is required.
2. Document all of the ISS interface parameters (data rate, total daily data downlink requirement, Ethernet and/or wireless capability, average power, peak power, survival power, mass, both static and dynamic volume envelope, field of view requirement, instrument expected readiness date for flight, on-orbit operation life requirement—operation end of life, external accommodation sites being requested).

ISS Feasibility Resource Accommodation Assessment Steps:

1. Contact the ISS RIO, at NASA JSC, to start the process. One of the following individuals should be contacted:
  - Kenol Jules (kenol.jules-1@nasa.gov, 281-244-5516)
  - George Nelson (george.nelson-1@nasa.gov, 281-244-8514)
2. Provide background information on the applicable AO that your team is responding, the Headquarters Program Scientist, and Program Executive contacts.
3. Provide the presentation material described above.
4. A telecom will be scheduled between RIO and the proposal team to review the submitted package.
5. RIO will assess the proposed concept's overall design approach and the RIO will inform the proposal team of the suitability of the proposed design concept to be accommodated on the ISS.

To complete the assessment, several follow-up telecoms/telecons, email exchanges, and additional data requests should be anticipated.

1. Once the ISS assessment team has reviewed all potential ISS accommodations and interface issues and have had resultant discussions with the proposal team, a draft preliminary ISS accommodation feasibility letter will be generated by RIO.
2. The draft feasibility letter will be reviewed with the proposer team for any comment. The content of the letter will focus on the issues identified by the assessment team, which will be discussed with the proposal team, and is solely based on the information provided by the proposal team during the assessment process.

3. The preliminary feasibility letter will be signed by the RIO manager and issued to the proposal team to be included as part of the proposal submission to NASA.
4. The whole process can take 6 to 8 weeks, depending on the complexity and maturity of the proposed design concept.

Once all the proposals are submitted to NASA, the ISS specific proposals will be reviewed again (in depth at this time) by RIO in order to issue a final ISS accommodation feasibility letter to NASA management, using information provided in the submitted proposals.

1. If an ISS proposal is selected for funding by NASA, the sponsoring NASA office will initiate contact with RIO to inform ISS of the selection of that proposal.
2. An Authorization to Proceed will be provided to RIO by the sponsoring NASA office to officially assign that instrument on ISS at a specific site, launch vehicle, and proposed flight date.
3. An ISS integration team will be activated by RIO to support the integration process of the selected instrument/payload on ISS.
4. Once the proposer/Principal Investigator/PD team is under contract with the sponsoring NASA office, an ISS kick-off meeting will be held at JSC to start the ISS integration process.

Table 2.2-1 provides a list of items that will be required from the PD to enable the ISS RIO to complete their assessment. The Table should be used in the body of the PD's proposal in the ISS Resource Accommodation Section of their proposals, as it is also used to determine ISS resources being requested by the proposers.

**TABLE 2.2-1 LIST OF ITEMS TYPICALLY REQUIRED TO COMPLETE THE ISS  
FEASIBILITY ASSESSMENT PROCESS**

Item Requested		Units	Value	References (proposal pg, section, ect.)†	Comments
Instrument Readiness Date (Ready to fly date)			Date		
Instrument Life Expectancy on ISS			x-years		
LEO Orbit Altitude	Nominal		miles		
	Acceptable range		miles		
LEO Orbit Inclination	Nominal		degrees		
	Acceptable range		degrees		
Sun Synchronous Orbit Equator	Nominal		xx:xx AM/PM		
	Acceptable range		xx:xx AM/PM		
Sun Synchronous Orbit Ground t	Acceptable range		days		
GEO Longitude	Nominal		degrees		
	Acceptable range		degrees		
Mass (Maximum Expected Value (MEV*))			kg		
Dimensions (l x w x h)			m x m x m		
Footprint Dimensions (l x w)			m x m		
Orbit Average Power (MEV*)			W		
Peak Power (MEV*)			W		
Average Power			W		
Survival Power			W		
Orbit Average Data Rate (Science and health and sta			kbps		
Peak Data Rate (MEV*)			kbps		
Data Interface		1553/ 422/ SpaceWire/ LVDS			
Data downlink to ground Requirement (daily)			GB/per day		
Data Latency Requirement			< x-hours		
Pointing control			degrees		
Pointing knowledge			degrees		
Pointing jitter			arcseconds		
Field Of View (FOV)	Direction		nadir/ zenith/ other		
	Breadth		degrees around nominal		
Sensor or Radiative Cooler Keep	Direction		nadir/ zenith/ other		
	Breadth		degrees around nominal		
Thermal Interface Requirements			Adiabatic/heat transfer required (W)		
ISS a potential platform?			Yes or No		
Any unique constraints the instrument places on ISS			Operational, data required from host (e.g. gyro), EMI/EMC, contamination, radiation, etc.		
Launch Environment Constraints			e.g. vibrations		
Do you have a preferred site/location for your			JEM/ELC/Columbus		
Does your instrument require active cooling?			Yes or No		
Instrument Operational Envelop Violation			mm in x/y/z axes		
*MEV (Maximum Expected Value) = Current Best Estimate (CBE) + Contingency					
† Please provide the location of this data in the body of the proposal (e.g., pages, sections, tables, and/or figures).					

## 2.3 WHAT YOU SHOULD KNOW

Section 3.0, Common Accommodations, Resources, and Environments Applicable to All ISS External Sites, of the Proposers Guide provides information on capabilities, accommodations, and environments common to all external payload sites on the ISS. The three ISS external payloads sites are outlined in Section 4.0, External Payload Sites Accommodations and Interfaces of the Guide, and include accommodations, capabilities, and limitations for each. The three sites identified in Paragraph 4.1,

Integrated Truss Assembly/ExPRESS Logistics Carrier, Paragraph 4.2, Japanese Experiment Module-External Facility (JEM-EF) and Paragraph 4.3, Columbus External Payload Facility (Columbus-EPF).

The ISS interface hardware for the ELC and Columbus are similar. Each site has a robotic interface and arm for installation/removal of payloads. The JEM-EF site has an active cooling loop for payload thermal control, whereas the ELC and Columbus sites are strictly thermally passive.

The ISS Program supplies much of the necessary hardware to attach payloads at these locations at no cost to you. A more detailed list of ISS-provided hardware and PD-supplied hardware is contained in Section 8.0, ISS Program-Provided Hardware and Section 9.0, Payload Developer-Provided Hardware.

Your design considerations must meet ISS requirements for interfaces and must fit into specific mass and volume allocations defined for each ISS external payload site. These three sites also provide power and data connector access. In addition, JEM-EF provides thermal control.

On any of ISS external payload sites, your payload will have neighboring payloads. These neighboring payloads, and the overall ISS performance, may have operational constraints of their own that affect your payload location choice, installation/removal of payload, and/or science operation. Operational constraints will be considered by the ISS RIO in their feasibility study for your proposed payload, and throughout the payload manifesting process. This is a “good neighbor policy.” This policy could impact your science expectations, for example, by limiting field of view (FOV), increasing contamination design sensitivity, decreasing on-orbit data downlink rates and power draw, increasing radiating/EMI/EMC sensitivities, or complicating thermal design. Ultimately, your design will need to conform to the parameters of flight, ground, and launch vehicle/visiting vehicle safety.

At this stage in the proposal process, you must be aware of a few limitations. First, your payload will require use of ISS robotics. For planning purposes, the ISS (ELC) and Columbus sites have no ISS-provided power for 6 hours while undergoing robotic manipulation. For a JEM-EF payload, there is no ISS-provided power for 7 hours. This power limitation is discussed in detail in Section 4.0. Second, carefully examine the ISS accommodations, outlined in Sections 3.0 and 4.0, for each external site. If your payload requirement(s) fall substantially outside the accommodations listed in Section 4.0, contact the Manager, ISS NASA Science and Technology Office. If the requirement is such that it cannot be waived, this might be a determining factor on whether to continue with the proposal process.

The level of effort required for supporting ISS payload analytical and physical integration, and the ISS safety data process, is a substantial effort that requires heavy documentation. For example, if selected, your support of the following will be required: design drawings and schematics of your payload and interface to the ISS; a payload Interface Control Document (ICD) and related ISS ICD's interface traceability; requirement documentation for all verification steps; computer aided design (CAD) and finite element models; materials lists; equipment lists; coupled loads analyses interaction and review of results; stress and thermal analyses for on orbit, robotics, and

launch loads; payload to visiting vehicle hardware and launch vehicle/visiting vehicle ICD information; thermal models; functional and physical configuration audits; safety, physical, and engineering documentation; and Kennedy Space Center (KSC) ground processing. The integration process is outlined in Paragraph 5.1, Integration, of this Guide, and Section 7.0, Flight and Ground Process, provides details for the ISS safety process.

The ISS operations process requires your submittal of data sets and participation in operations discussions and meetings to ensure operations requirements are met. Paragraph 5.2, ISS Operations, outlines the accommodations for ISS payload operations.

Consultation with the ISS RIO is recommended to assist you in producing accurate and complete estimates for your proposed labor, schedule, and cost. A complete understanding of the breadth of the interaction and deliverables with the ISS Program will minimize surprises down the road. Again, Paragraph 5.1 and Section 7.0 will assist you in determining the approximate level of effort required.

*If it is necessary to waive a requirement in your proposal that is determined to be vital to continuing with your proposal effort, please contact the Manager of ISS NASA Science and Technology Office or the point of contact named in the AO.*

For selection of your launch vehicle/visiting vehicle and corresponding integration and safety processes, please refer to Section 6.0, Launch Vehicles and Visiting Vehicles Supporting ISS External Payloads, of the Guide.

## 2.4 ORGANIZATIONAL ROLES/RESPONSIBILITIES

ISS Research Integration Office. The ISS RIO, located within the ISS Program Office, is located at JSC. The ISS RIO, and more specifically, the Manager, ISS NASA Science and Technology Office, will serve as your interface during proposal formulation. After proposal selection, a PIM will be assigned to serve as your primary point of contact for interfacing with the ISS.

The ISS RIO, through the PIM, also functions as the program/technical interface for the launch vehicle/visiting vehicle throughout the process and will provide direction with regard to any launch vehicle/visiting vehicle interface requirements that need your consideration in ground processing launch environments and on-orbit installation and removal operations. ISS RIO ensures that the document is applicable to all external payload users.

Marshall Space Flight Center (MSFC) (Located in Huntsville, AL): The ISS operations function for ISS payloads has been designated to MSFC. Your interface with the ISS/MSFC team will commence during later stages of design/development as outlined in Paragraph 5.2, ISS Operations.

Kennedy Space Center (KSC, FL): KSC functions as the primary ISS facility interface for payload processing and final verification, and launch processing in coordination with the launch vehicle/visiting vehicle provider. Ground processing will involve coordination with NASA, NASA's launch site payload processing personnel, NASA's contracted launch services provider, and the launch range safety office.

Earth Systematic Mission Program Office (Goddard Space Flight Center (GSFC)) (Located in Greenbelt, MD): For questions about the contents of this Guide, please contact the GSFC, Earth Systematic Mission Program Office.

Earth Science Systematic Program (ESSP) (Langley Research Center (LaRC)) (Located in Hampton, VA): ESSP participated in development of the Guide and ensure compatibility to Earth Venture (EV) AOs.

Although the sponsoring organization for the JEM-EF is the Japan Aerospace Exploration Agency (JAXA) and the sponsoring organization for Columbus is the European Space Agency (ESA), for U.S.-sponsored payloads your primary point of contact will continue to be the ISS RIO (JSC) during the proposal process.

## **2.5 ROLES/RESPONSIBILITIES OF PAYLOAD PROVIDERS**

Your responsibility is, simply, to provide the required ISS accommodation resources, technical, management, risk, safety, and cost information in your payload proposal to meet the ISS interface and safety requirements. For any questions on ISS accommodations or interfaces, contact the appropriate organizations as quickly as possible. The ISS Program is fully prepared to help during the proposal process; however, it is your responsibility to develop the necessary knowledge of the ISS to formulate your proposal.

### 3.0 COMMON ACCOMMODATIONS, RESOURCES, AND ENVIRONMENTS APPLICABLE TO ALL ISS EXTERNAL SITES

This section contains very important ISS information, and reviewing this section is the first step in understanding the technical accommodations information that you will utilize for your proposal. Accommodations, interfaces, and environments common to all three external sites are included in this section of the Guide. These include: a general overview of the ISS, the ISS Command & Data Handling (C&DH) system, ISS robotics, ISS Attitude and Pointing, Pointing Accuracy, Micrometeoroid and Orbital Debris, Magnetic Field and Gravitational Field, Electro-Magnetic Radiation, Contamination, Atomic Oxygen, Contingency Extravehicular Activity (EVA), and End of Mission.

#### ISS Overview

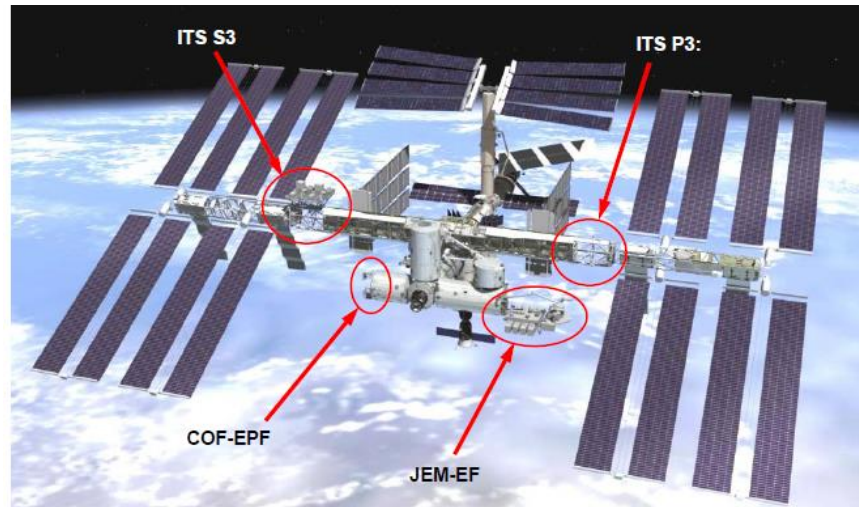
The ISS consists of pressurized modules, external trusses, solar arrays, and many other components. The ISS serves as a microgravity and space environment research laboratory in which crewmembers conduct experiments in numerous scientific disciplines: astronomy, biology, physics, and numerous microgravity research disciplines. It may also be utilized for the testing of spacecraft systems and equipment required for missions to the Moon and Mars.

Since November 2000, the ISS has been continuously occupied, which is the longest continuous human presence in space. The ISS a joint project among five participating space agencies: NASA, State Space Corporation (Roscosmos), JAXA, ESA, and the Canadian Space Agency (CSA). The ownership and use of the ISS is established by intergovernmental treaties and agreements. The ISS maintains an Earth-orbit with an altitude of between 330 km (205 mi) and 425 km (270 mi) by means of re-boost maneuvers, and it completes 15.51 orbits per day.

The Integrated Truss Segment (ITS) provides the backbone structure for the ISS. It attaches the solar and thermal control radiators to the rest of the complex; houses cable distribution trays, EVA support equipment such as hand-holds and lighting; and provides for extravehicular robotic (EVR) accommodations using the Mobile Servicing System (MSS). The ITS also provides logistics and maintenance as well as payload attachment sites. The attachment sites accommodate logistics and maintenance and payloads carriers, both zenith and nadir.

The ELC, which is attached to the ITS, can accommodate multiple payloads, and currently, there are four separate ELC sites on the ISS truss. The JEM-EF, a back-porch-like attachment to the JEM Pressurized Module (JEM-PM), accommodates external payloads, which can be serviced by the crew via the JEM-PM airlock and dedicated robotic arm. The Columbus-EPF is another back-porch-like platform that can accommodate two zenith- and two nadir-looking payloads.

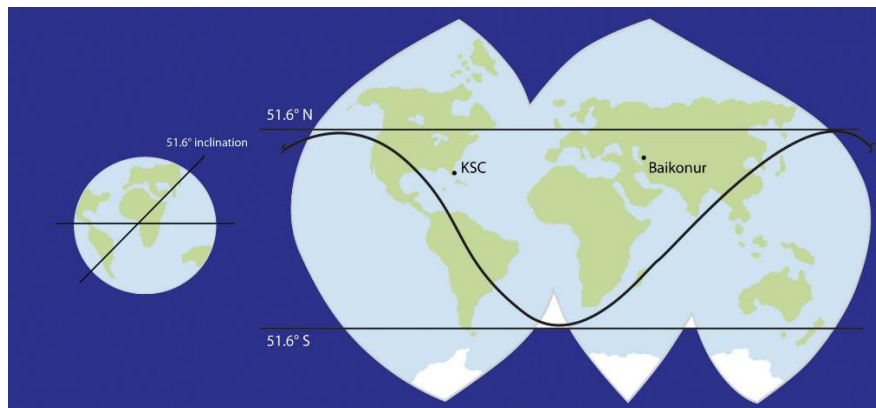
There are 10 JEM-EF external payload mounting locations for hosting external payloads. Five of the 10 locations are allocated for NASA external payloads. None of the allocations are location specific. The Columbus-EPF can accommodate four external payloads, two of which are provided to NASA and are also not specified. Figure 3.0-1, External Payload Attachment Locations, shows the locations of the Columbus-EPF and the JEM-EF.



**FIGURE 3.0-1 EXTERNAL PAYLOAD ATTACHMENT LOCATIONS**

Although the ISS crew provides hands-on tasks for pressurized payloads, this capability is not generally offered to external payloads. The vast majority of external payloads are remotely operated from ground stations and from the PD's science facility.

As shown in Figure 3.0-2, ISS Orbit, the ISS maintains a 51.6° inclination, with the corresponding ground coverage area.



**FIGURE 3.0-2 ISS ORBIT**

The ISS provides a myriad of capabilities and accommodations, some of which are outlined in Table 3.0-1, On-Orbit Payload Resources.

**TABLE 3.0-1 ON-ORBIT PAYLOAD RESOURCES**

Power	30 kw (average)
Internal Payload Racks	13 NASA Lab
	11 ESA Lab
	10 JAXA Lab
External Sites	8 NASA Truss ELC Platform Sites
	10 JAXA Platform Sites
	4 ESA Platform Sites



### ISS Command and Data Handling (C&DH) Overview

The ISS C&DH system consists of hardware and software that provide services for command, control, and data distribution for all ISS systems, subsystems, and payloads (see Figure 3.0-3, ISS C&DH Architecture Diagram). The top level (system-level) C&DH architecture contains redundant command and control (C&C) multiplexer/demultiplexers (MDMs) and MIL-STD-1553B<sup>14</sup> control buses. The external payload services includes the payload MDM Low Rate Data Link (LRDL) (1553B local bus) data and command distribution, a High Rate Data Link (HRDL) for payload-to-payload communication and data downlink, and both a wired and wireless Ethernet Medium Rate Data Link (MRDL). LRDL (other than payload safety-related) data are downlinked via the HRDL to the ground. Safety-related data are routed via the C&C MDM to the S-band data services for downlink. The Portable Computer System (PCS) is used by the on-board crew for command and display interfaces. Payload commands can be uplinked from a ground site, issued from the PCS, or issued by a payload MDM automated procedure.

Enhanced features for payload communications include direct two-way Ku-band links between a user and their ISS instrument via Ethernet using standard internet protocols. These capabilities use the additional network services provided by the onboard Joint Station Local Area Network (LAN) (JSL), of which the payload Ethernet MRDL is a part, and the ground Payload Operations Integration Center (POIC). Refer to SSP 50304, Payload Operations and Integration Center (POIC) Capabilities Document.<sup>38</sup>

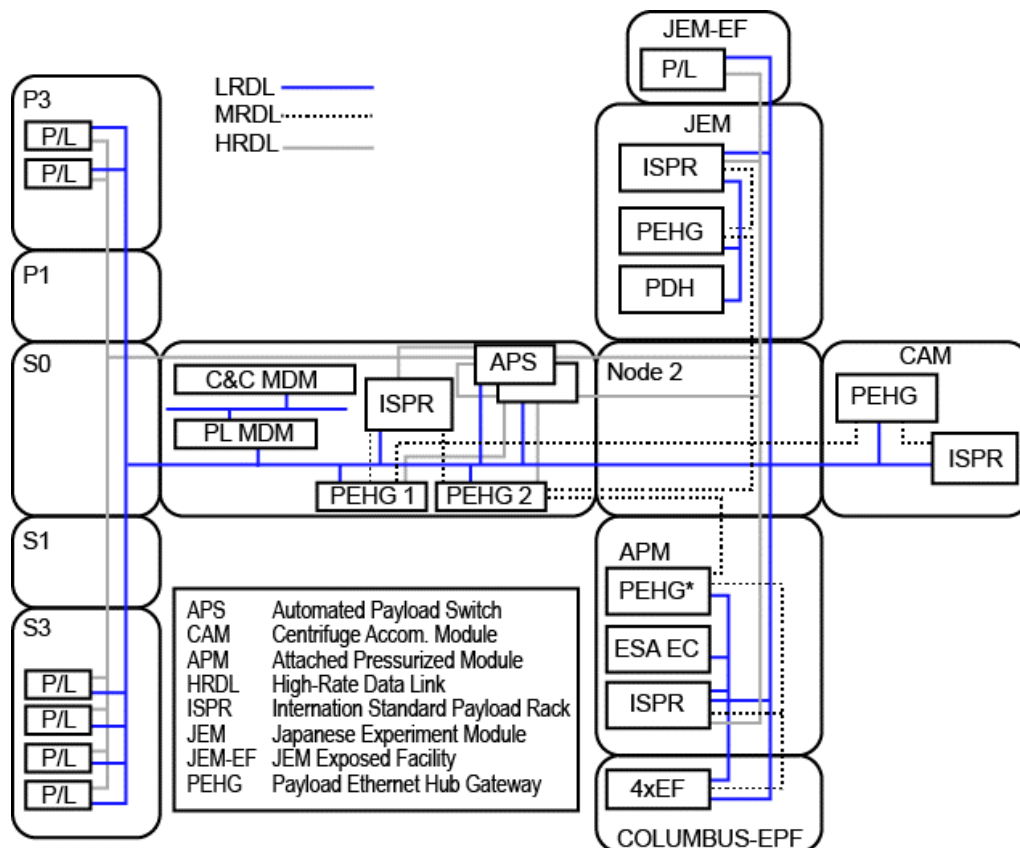


FIGURE 3.0-3 ISS C&DH ARCHITECTURE DIAGRAM

Capabilities, such as power, microgravity environments, structural attachment interfaces, C&DH capabilities, etc. for each site, are discussed in the subsequent sections.

### **3.1 COMMON ACCOMMODATIONS AND RESOURCES APPLICABLE TO ALL ISS EXTERNAL SITES**

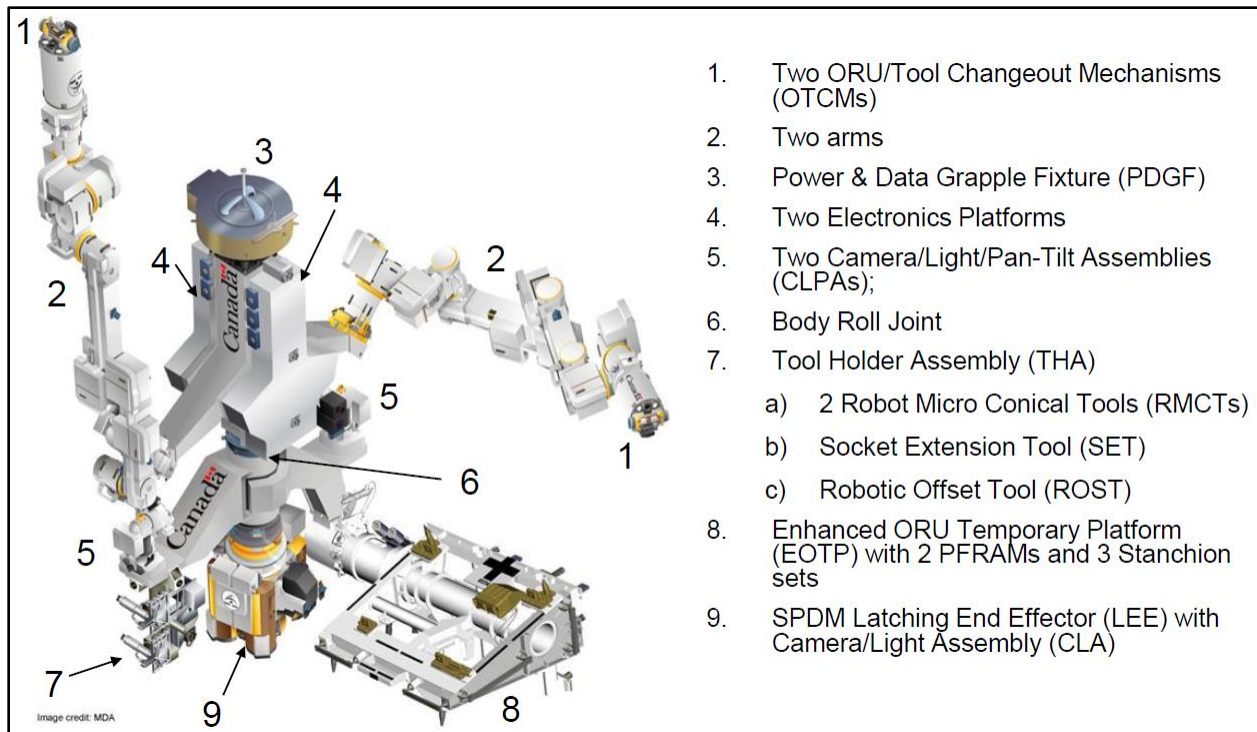
The following additional factors that a proposer should consider for their proposal are outlined in the following subsections. These factors are virtually identical for all three external payload locations.

#### **3.1.1 ISS ROBOTICS OVERVIEW**

The following provides a general overview to the ISS robotics systems, which each external payload will utilize. The proposer will need to have a basic understanding of these systems in order to provide a sound, technically accurate proposal.

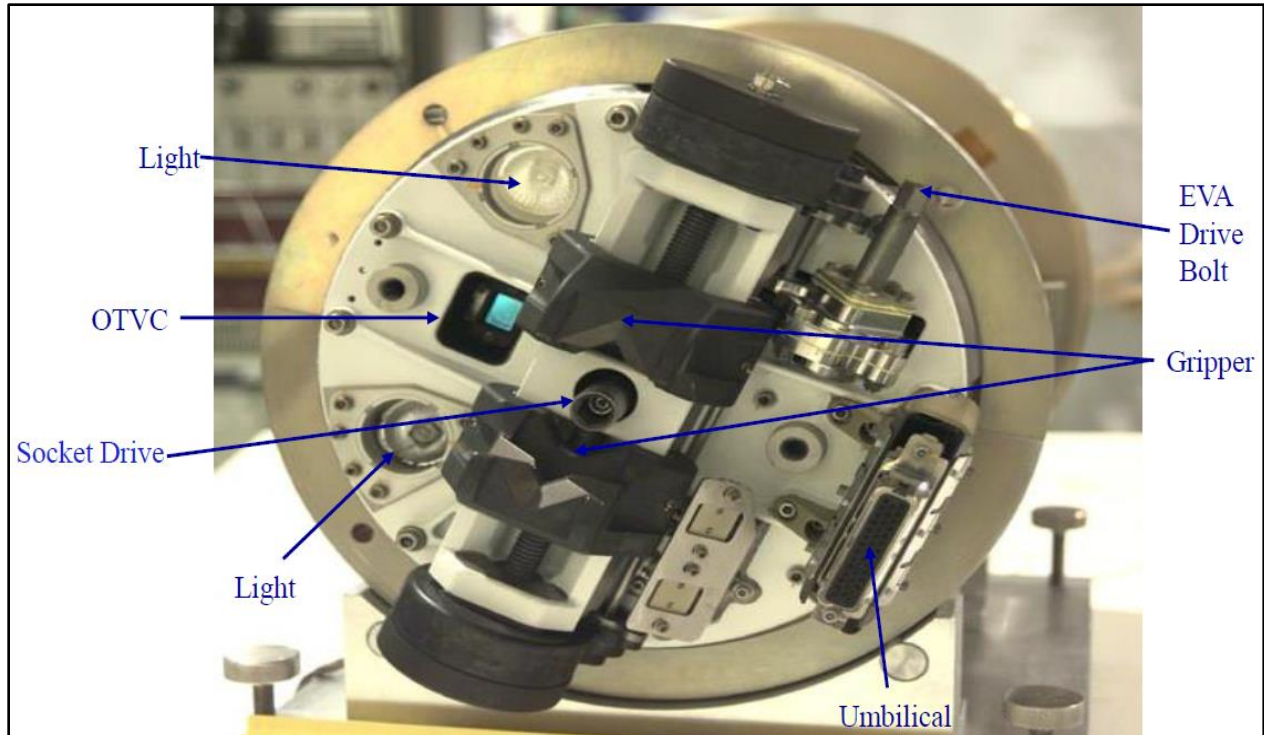
The Special Purpose Dexterous Manipulator (SPDM), or Dextre, in conjunction with the Space Station Remote Manipulator System (SSRMS), is used to manipulate payloads or payload components. Dextre and the SSRMS are two external components of the MSS of the ISS. The other external components of the MSS are the Mobile Transporter and the Mobile Base System (MBS), which provide re-locatable accommodations for SSRMS and Dextre along the ITA. Internally, the Robotics Workstations are utilized by the on-board crew to operate the external components of the MSS. Direct robotic interactions with payloads are predominantly through Dextre, although for payloads with a mass greater than 600 kg (1320 lbs) the SSRMS will be primary manipulator, and all of the robotic payload operations are controlled by ground-based operators in Mission Control Center – Houston (MCC-H).

Dextre's construction consists of a Latching End Effector (LEE), the Enhanced Orbital Replacement Unit (ORU) Temporary Platform (EOTP), a Body Roll Joint, two arms, a tool holster, a Power and Data Grapple Fixture (PDGF), and four cameras. Figure 3.1.1-1, ISS Dextre, illustrates Dextre.



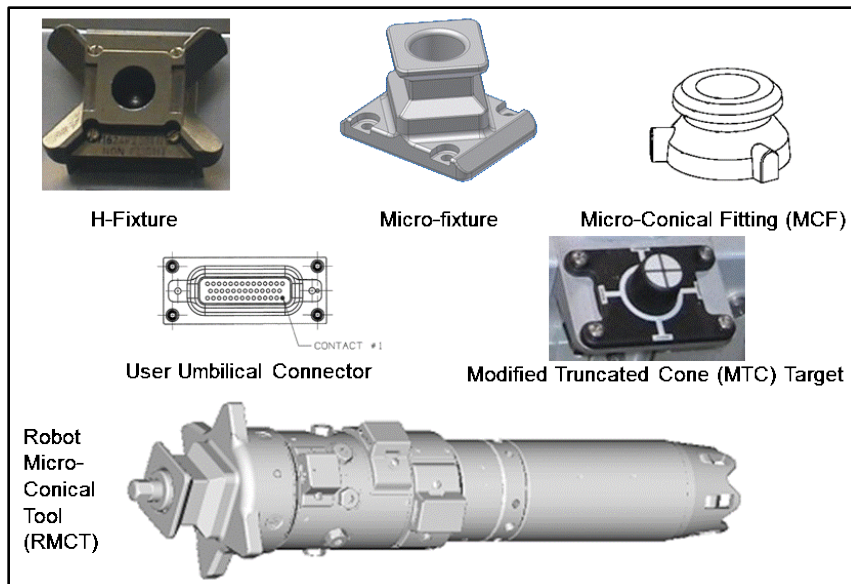
**FIGURE 3.1.1-1 ISS DEXTRE**

Dextre's manipulation control is provided by two seven-jointed arms, which are both terminated with ORU/Tool Change-out Mechanisms (OTCMs). The OTCMs attach to specially designed fixtures on a payload and feature a retractable motorized socket wrench used to torque bolts, a retractable umbilical connector used to provide electrical, data, and video connections to payloads, and a camera and lights used for close-up viewing and to align the OTCM with the fixtures using targets. Figure 3.1.1-2, Dextre OTCM, illustrates the OTCM.

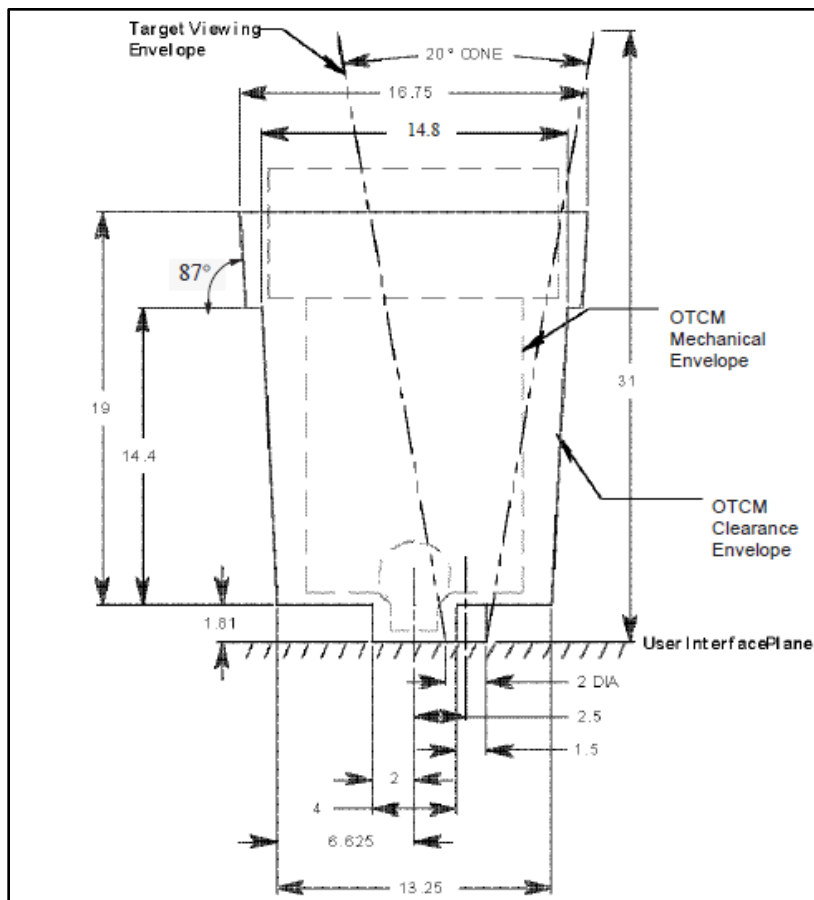


**FIGURE 3.1.1-2 DEXTRE OTCM**

There are a number of interfaces available to allow interaction of Dextre with a payload. The various interfaces are shown in Figure 3.1.1-3, Dextre Interfaces. The standard interface is a Micro-fixture, which is also known as a Micro-square, which allows for a direct grasp by the OTCM. Having a Micro-fixture allows for the use of a collocated bolt as well as an umbilical connector for access to power, data, and video through the OTCM. In order to access the Micro-fixture, a payload must leave enough space around the fixture to accommodate the OTCM clearance envelope as shown in Figure 3.1.1-4, OTCM Clearance Envelope. Like a Micro-fixture, an H-fixture also allows for a direct grasp with the OTCM as well as allowing for the use of a collocated bolt and umbilical connector. However, H-fixtures are usually only utilized on payloads for high-load or high-mass cases. For payloads that require Dextre interaction, but cannot accommodate the OTCM clearance envelope, a Micro-Conical Fitting (MCF) is available. The MCF requires the use of the Robot Micro-Conical Tool (RMCT), which has a much smaller clearance envelope as shown in Figure 3.1.1-5, RMCT Clearance Envelope. The MCF allows for the use of a collocated bolt, but does not allow for the use of an umbilical connector. Acquiring the RMCT also has operational overhead, which must be accounted for when planning payload operations.

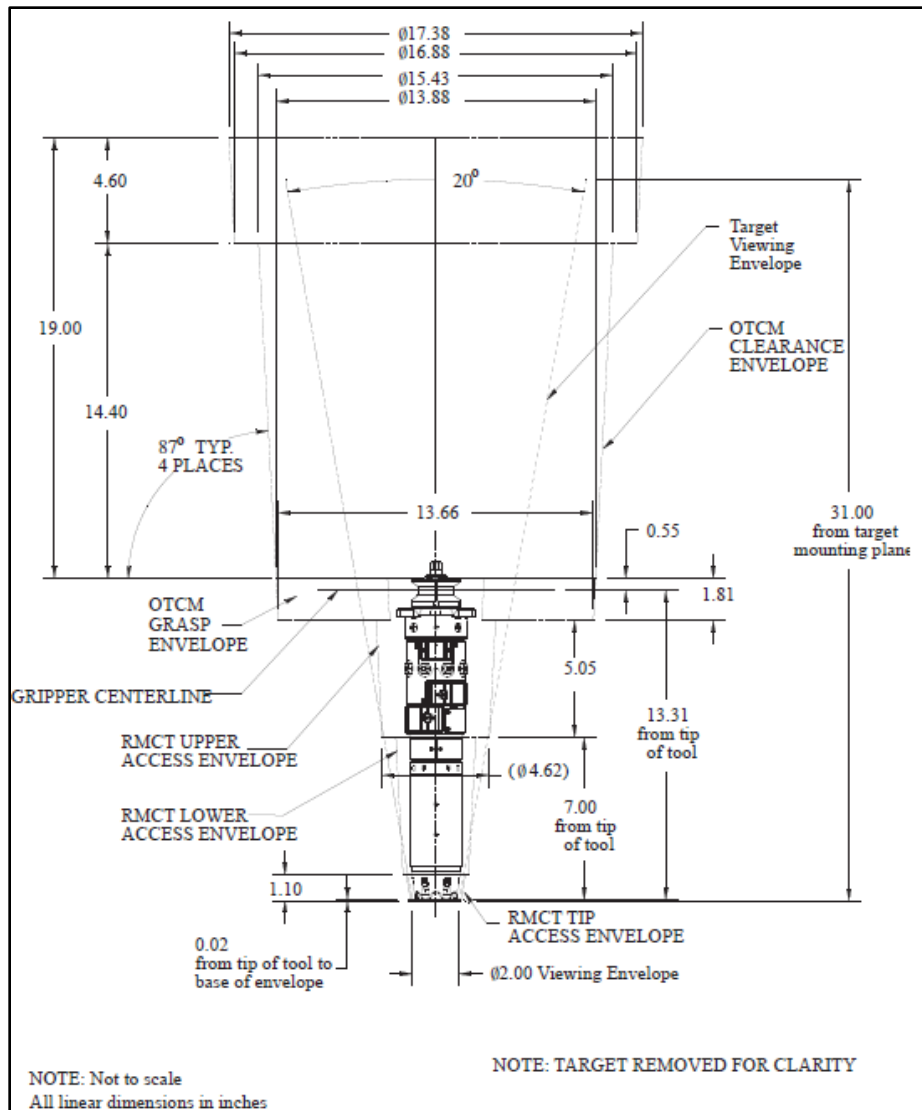


**FIGURE 3.1.1-3 DEXTRE INTERFACES**



NOTE: Not to scale. All Linear dimensions in inches.

**FIGURE 3.1.1-4 OTCM CLEARANCE ENVELOPE**



**FIGURE 3.1.1-5 RMCT CLEARANCE ENVELOPE**

As previously mentioned, for payloads with a mass above 600 kg (1320 lbs), the SSRMS is required for manipulation of the payload. The SSRMS is a single seven-joint arm terminated on either end with two LEEs. There are four color cameras. Figure 3.1.1-6, ISS SSRMS, illustrates the SSRMS. The SSRMS is symmetrical which allows it to “walk off” between seven base locations across the ISS (one on Node 2, one on the U.S. Laboratory (USL), four on the MBS, and one of the Functional Cargo Block (FCB)).

Interfacing with the SSRMS requires the use of one of the two types of grapple fixtures as shown in Figure 3.1.1-7, SSRMS Grapple Fixtures. The standard interface is a Flight Releasable Grapple Fixture (FRGF). This type of grapple fixture only allows for a simple mechanical attachment with the SSRMS LEE. The other available fixture for interfacing with the SSRMS is the Power and Video Grapple Fixture (PVGf). A PVGF not only provides the simple mechanical interface of the FRGF, but also has connectors, which provide access to the power, video, and data services through the

SSRMS. The SSRMS is also latched to PVGF when utilizing the connectors, which increase the rigidity between the SSRMS and the payload.

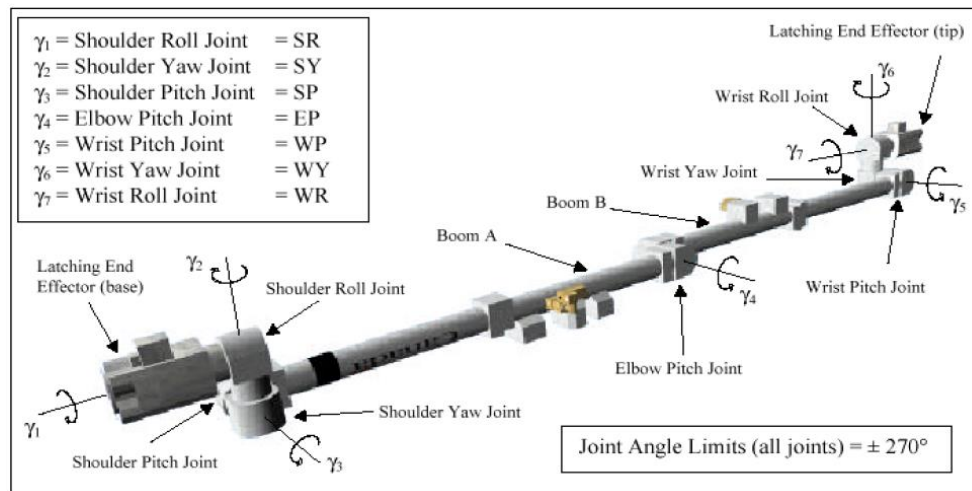


FIGURE 3.1.1-6 ISS SSRMS

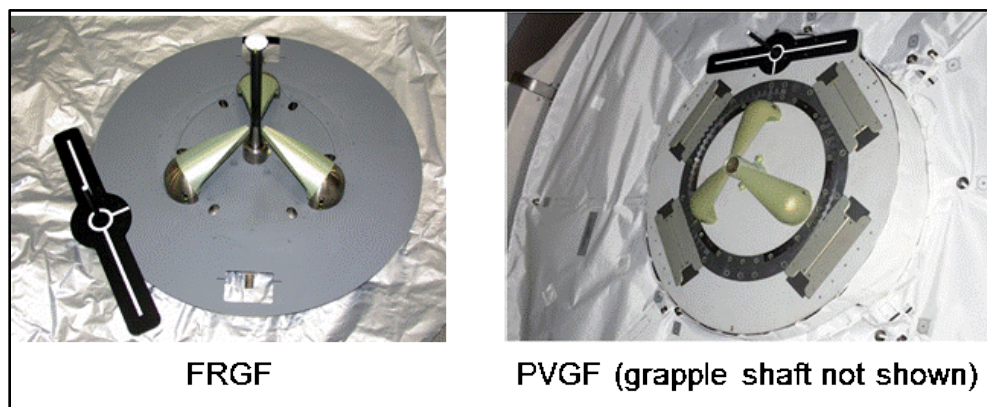


FIGURE 3.1.1-7 SSRMS GRAPPLE FIXTURES

There are number of things that a PD needs to be cognizant of when being involved with the SSRMS and the SPDM:

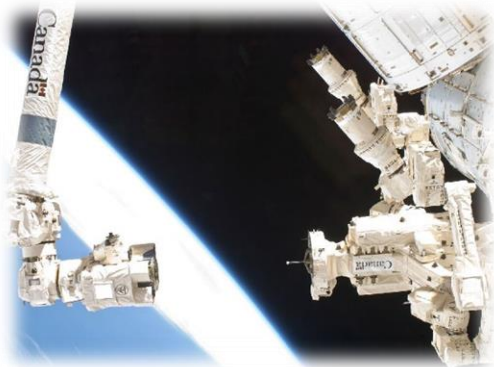
- Unpowered survival – Unless a payload is equipped with an umbilical connector to access power through an arm, the payload will be unpowered during transport phases. The required unpowered survival time is 6 hours for FRAM-based payloads and 7 hours for EF-type payloads. The expectation is that a payload will “fail-safe” in the event power cannot be applied within the payload’s analyzed survival clock.
- Impact energy – While being manipulated by one of the robots, a payload can be at risk for impact when clearances between the payload and some other structure are within certain ranges (3 to 6 inches when SPDM is in motion, 12 inches when the SSRMS is in motion). A payload that interfaces with the SPDM is expected to be able to take a 1-Joule impact in any areas that are within the clearance ranges for each of the robots depending on which robot is in motion at any one time. For payloads interfacing with the SSRMS, an

equation determines the impact energy that could be imparted based on the payload's mass. PDs are encouraged to evaluate their entire payload for impact to provide the maximum operational flexibility throughout the life of the payload, but specific areas of potential contact will be determined with the help of the robotics community. Areas at risk for impact are expected to "fail safe" and not result in a catastrophic failure.

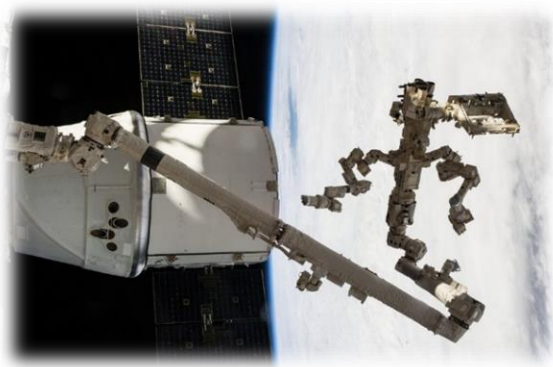
- EOTP – All FRAM-based payloads are expected to protect for the use of the EOTP for their installation phase and their disposal phase. The main issue is electrical compatibility. Fuses need to be in place on the payload side to protect the EOTP's 4A fuses, which are only replaceable via EVA. Also payload wiring needs to be such that, when installed on the EOTP, motors or any other type of reactive load are not being powered.
- Government-furnished equipment (GFE) – Hardware to interface with the robots is provided to the PD by NASA except for cases where the PD intends to modify the hardware. In that case, the hardware specifications are provided to the PD for use in building their modified hardware. Analysis, testing, and drawings of the modified hardware are expected as part of the verification and acceptance of the hardware for use with the robots.

Figures 3.1.1-8 through 3.1.1-11 represent the ISS Robotics Sequence for an ELC payload at a high-level.

Figures for a Typical ISS Robotics-Payload Sequence for an ELC payload:

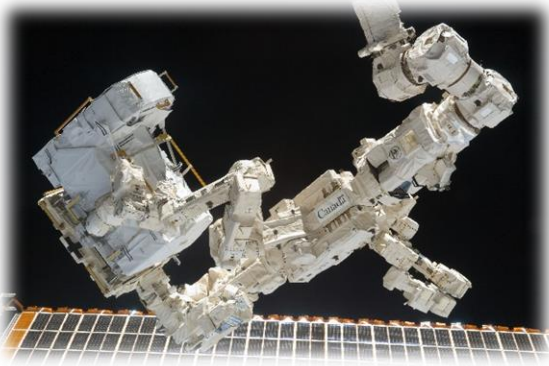


**FIGURE 3.1.1-8 ISS CANADA ARM 2 PICKS UP DEXTRE**



**FIGURE 3.1.1-9 DEXTRE REMOVES PAYLOAD FROM DRAGON**





**FIGURE 3.1.1-10 DEXTRE CARRIES PAYLOAD TO SITE**



**FIGURE 3.1.1-11 PAYLOAD IS INSTALLED INTO SITE**

### 3.1.2 WIRELESS CAPABILITY

The ISS JSL provides Ethernet connectivity for internal wired, internal wireless and external wireless devices. The Proposers Guide will focus on the external wireless segment of JSL system (known as the External Wireless Communication (EWC)). The EWC is comprised of Wireless Access Points (WAPs) and antennas located on the USL module. EWC provides two-way data transfer between payload sites and the payload virtual LAN (VLAN) on the JSL. The JSL EWC system provides standard 802.11n two-way high-data rate communication links using radio frequencies from the “U.S.” Regulatory Domain.

EWC expansions with additional capacity and coverage is expected to be phased in during the years 2017 to 2019. The EWC expansion plan includes installation of an additional WAP and antenna pair on the Node 3 port end-cone to provide better coverage to the JEM-EF’s aft-facing payloads. Also included in the EWC expansion plan is the placement of WAPs located at several truss locations both outboard and inboard of the ELCs. Individual payloads should typically have visibility to one or two WAPs.

EWC infrastructure antennas will be a mix of linear polarization (LP) and Right-Hand-Circular Polarization (RHCP). The USL and Node 3 WAPs use LP antennas mounted externally on the modules. The expanded EWC will use RHCP antennas on booms located at various points along the truss (P3 aft, S3 aft, and camera ports 3, 8, 9, and 13).

ELC in-board locations can achieve line-of-sight coverage to antennas located on the USL or Node 3. The outboard EWC WAP locations (P3 and S3) will provide coverage to payloads located on the outboard faces of the ELCs. When the EWC expansion is complete, all aft facing JEM-EF ports will have EWC line-of-sight coverage to one or more WAPs. Some forward or ram facing sites may be blocked due to other payloads on the JEM-EF obscuring line of sight to the EWC. Coverage of Columbus-EPF is planned to be provided using a single WAP installed on the truss during 2019. Some adaptor locations may have visibility to a second WAP

Each payload needs to work with the ISS Program to ensure their antenna is selected, located, and oriented to achieve sufficient link closure with an EWC WAP within the payload's coverage area.

The NASA provided EWC Payload Hardware GFE consists of the following items:

	Part Number	Part Name	Notes
1	684-015637-0001	Payload Antenna Coax Cable Assembly	Connects Payload's EWC Network Interface Card to payload antenna
2	684-015636-001	EWC Payload Antenna	A linearly polarized 17dBi 16° beamwidth antenna, 9" x 9" x 3". Proper directional orientation (pointing) is required to achieve maximum link margin.
3	AWK-4131-M12-CT-T	MOXA Wireless Access Point	WAP form factor WiFi client, collects payload data for transmission by the payload antenna.

Other antennas and Access Points (AP) may be used but are not GFE. For example, the Tecom 106002 low-gain RHCP antenna has heritage with some existing EWC users.

The EWC user data rate varies based many factors, but is expected to range from 10–50 Mbps shared bandwidth. Application-layer network throughput is variable per EWC WAP. This rate is shared among all users of that WAP in both directions. The number of users per WAP is constrained by the traffic load presented by those users. In practice, competing traffic generated by other payloads may vary according to operating conditions, experiment timeline, or ISS operations timeline. It is possible to achieve higher rates if both the payload and the ISS antennas and WAPs are configured for multiple input, multiple output (MIMO) operations. The payload must identify the need for MIMO operations to determine if MIMO can be supported at their location. Future JSL EWC upgrades are expected to include rate upgrades such as utilization of 802.11ac.

The payload developer must identify if they are requesting the NASA-provided EWC GFE or if they are supplying their own EWC equipment (radio or antenna) to connect to the JSL EWC segment. EWC is a shared JSL network resource using unlicensed spectrum. Payload users of EWC may be required to throttle peak data rates by ISS payload operations.

Finally, it should be noted that all radio frequency (RF) operation around the ISS requires advance approval of the transmitting equipment through the ISS RF authorization process. The payload developer will submit the RF system characteristics and planned operating location information via the JSC Radio Frequency Spectrum Management Homepage (<http://ea.jsc.nasa.gov/webapp/fmdb/login.asp>). The initiation of this review process is recommended after System Requirements Review and well ahead of Preliminary Design Review (PDR). The payload developer is also responsible for obtaining the required regulatory license grant and submit to the JSC Spectrum Management Office to support the completion of the ISS compatibility review process.

### 3.1.3 ATTITUDE AND POINTING

External payloads should be designed, and remain safe, while accommodating the ISS attitude and pointing environment described in Table 3.1.3-1, ISS Attitude and Point Environment.

**TABLE 3.1.3-1 ISS ATTITUDE AND POINT ENVIRONMENT**

Attitude	Duration	Variation
+XVV Torque Equilibrium Attitude (TEA)	95% of Flight Time	Any combination of ±15° Roll (about X axis) ±15° Yaw (about Z axis) +15 to -20° Pitch (about Y axis)
-XVV Z-Nadir (Local Vertical Local Horizontal (LVLH))	<5% of Flight Time	Any combination of ±15° Roll +165° to +195° Yaw +15° to -20° Pitch
+ZVV -X-Nadir (LVLH)		Any combination of ±15° Roll ±15° Yaw +75° to 105° Pitch
-ZVV -X-Nadir (LVLH)		Any combination of ±15° Roll +165 to +195° Yaw +75° to +105° Pitch
+YVV Z-Nadir (LVLH)		Any combination of ±15° Roll -110° to -80° Yaw +15° to -20° Pitch
-YVV Z-Nadir (LVLH)		Any combination of ±15° Roll +75° to +105° Yaw +15° to -20° Pitch

**Notes:**

The attitude variations include variations in the TEA as well as variations in the ISS attitude from the TEA attitude. XYZ axes refer to the ISS coordinate system orientation

It should be noted, for example, that a hardware offset might be designed to provide the attitude needed for an instrument or an instrument might opt to have a pointing mechanism system for accurate pointing if needed. ISS does not provide an attitude predictive capability, but does maintain historical data. However, this data will probably be of minimal benefit in predicting future ISS attitudes and pointing profiles.

Pointing Accuracy

Limitations exist for the degree of pointing accuracy on any payload attachment site. For example, the S3 site, which has the best ISS historical pointing accuracy data, has a fixed alignment error of 0.2 to 0.5°/axis, 3σ. There is also a time-varying error (with a period of the order of an orbit) of ±0.08° for roll and pitch, and +0.23/−0.10° in yaw due to thermal bending of the truss. There is also a random error of 0.001 to 0.02°/axis, 3σ in position knowledge.

Jitter

On ISS, the proposer should be aware that there is a time-varying error (with a period of the order of an orbit) of ±0.08° for roll and pitch, and +0.23/−0.10° in yaw due to thermal bending of the truss. There is also a random error of 0.001 to 0.02°/axis, 3σ in position knowledge.

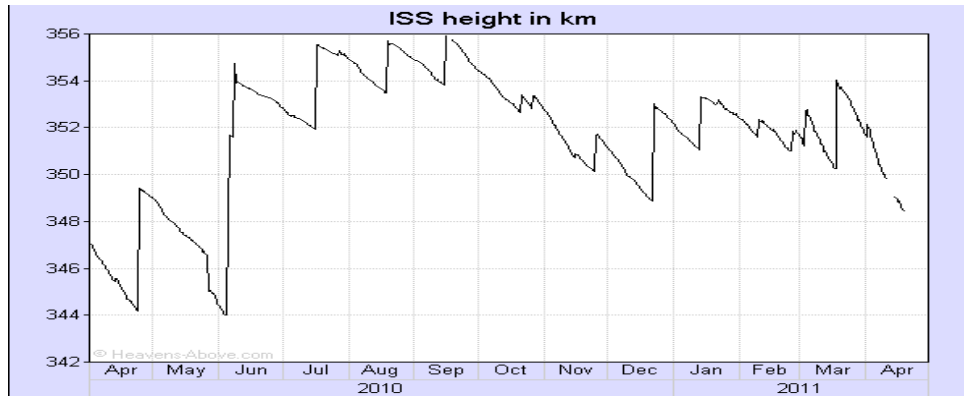
A depiction of the Guidance Navigation and Control (GN&C) performance regarding jitter is given in Table 3.1.3-2, GN&C Performance Regarding Jitter. Please note that the pointing jitter due to microgravity disturbances is estimated to be on the order of 0.03° in quiescent mode (no thruster firings, dockings, EVA or robotics operations, etc.).

**TABLE 3.1.3-2 GN&C PERFORMANCE REGARDING JITTER**

Parameter	Requirement	Typical/Predicted Performance
Attitude rate: non micro gravity	±0.02°/sec/axis	±0.005°/sec/axis
Attitude knowledge at navigation base (S0 truss)	±0.5°/axis 3σ	<0.25°/axis 3σ
Attitude knowledge on the non-articulated portion of the ISS (incl. JEM-EF)	3.0°/axis 3σ	<1.0°/axis 3σ

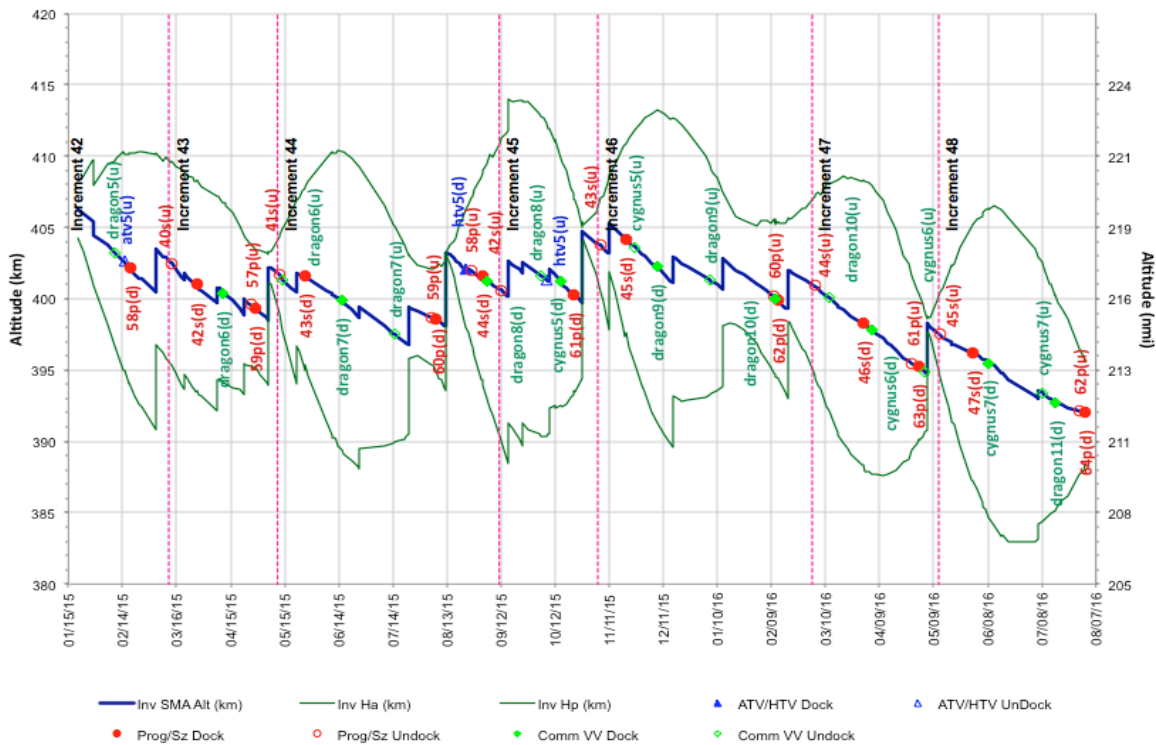
**3.1.4 ATTITUDE/ALTITUDE ADJUSTMENTS/CORRECTIONS**

The wide range of altitude is due to ISS continuously losing altitude because of atmospheric drag, thus periodic re-boosts are needed to counteract this decrease. The rate of descent varies over time due to solar activity as indicated in the sample Figure 3.1.4-1A, ISS Altitude Profile and Figure 3.1.4-1B, ISS Reference Trajectory Attitude Profile.



**FIGURE 3.1.4-1A ISS ALTITUDE PROFILE**

**February 2015 ISS Reference Trajectory Altitude Profile with Invariant Ha and Hp Values**



**FIGURE 3.1.4-1B ISS REFERENCE TRAJECTORY ATTITUDE PROFILE**

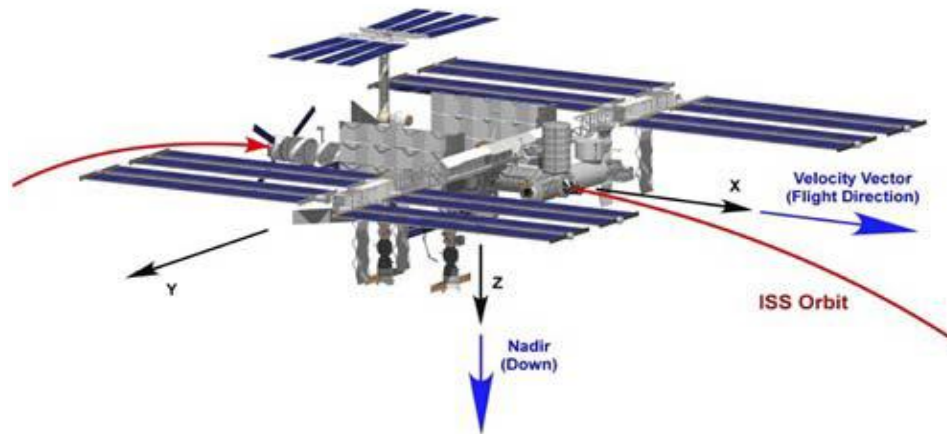
Figures 3.1.4-1A and B are graphs of the average altitude off ISS during certain months in 2015. This is the average altitude but the apogee and perigee of the orbit can vary as much as 25 km within any single orbit (as shown).

The attitude of the ISS is defined by the classical pitch, yaw and roll angles, according to the Local Vertical Local Horizontal (LVLH) coordinate system, and generalized as depicted in Figure 3.1.4-2, +XVV Orientation of ISS.

Attitude & Ephemeris (State Data)

The ISS GN&C flight software provides navigation and pointing data to ISS payloads. Examples of these parameters are:

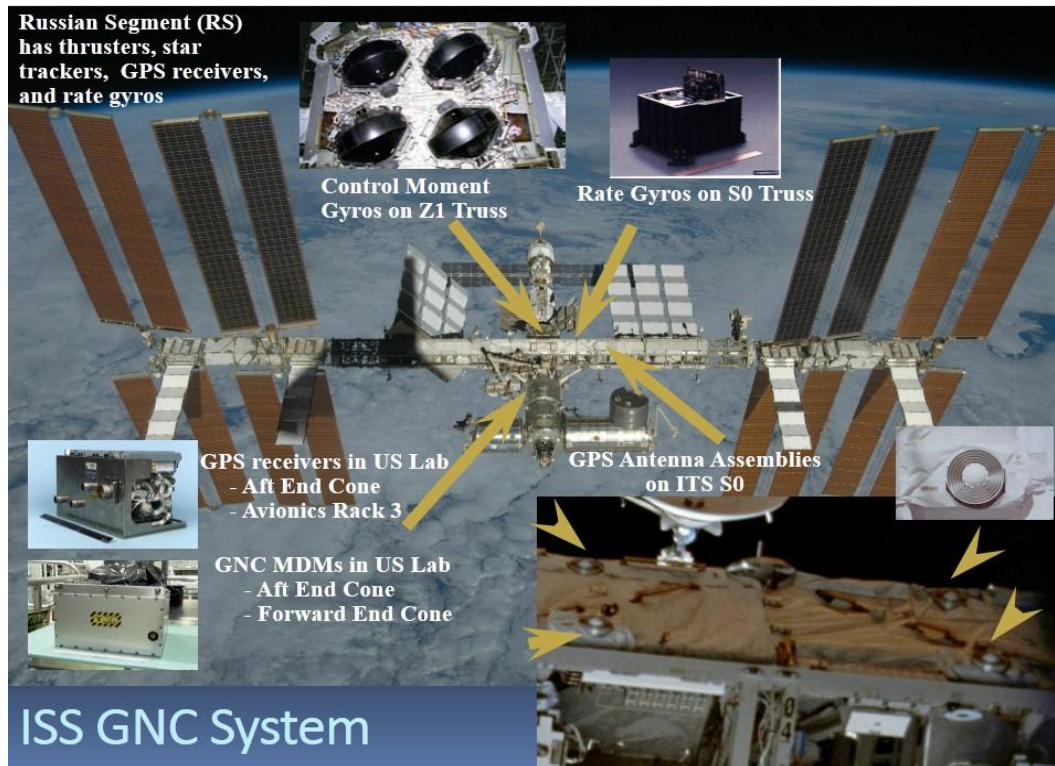
- Attitude and rate knowledge
- State-vector (position and velocity)
- Mass properties estimates (center of gravity (C.G.), etc.)
- Solar array (in-plane) and Beta (out-of-plane) sun tracking angles
- Solar line-of-sight unit-direction-vector components



**FIGURE 3.1.4-2 +XVV ORIENTATION OF ISS**

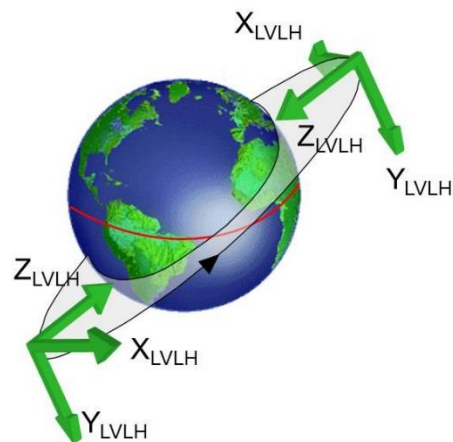
### **3.1.5 OVERVIEW OF ISS GUIDANCE, NAVIGATION, AND CONTROL (GN&C)**

The ISS can use the U.S. segment for non-propulsive control, utilizing four Control Moment Gyroscopes (CMG), or ISS can use Russian segment for propulsive, or thruster, control. ISS flies in a LVLH attitude utilizing U.S. CMG control as much as possible. Vehicle dockings/undockings and berthings/unberthings typically require periods of thruster control, and occasionally require attitude maneuvers. Figure 3.1.5-1, ISS GN&C System, shows the ISS GN&C system hardware.



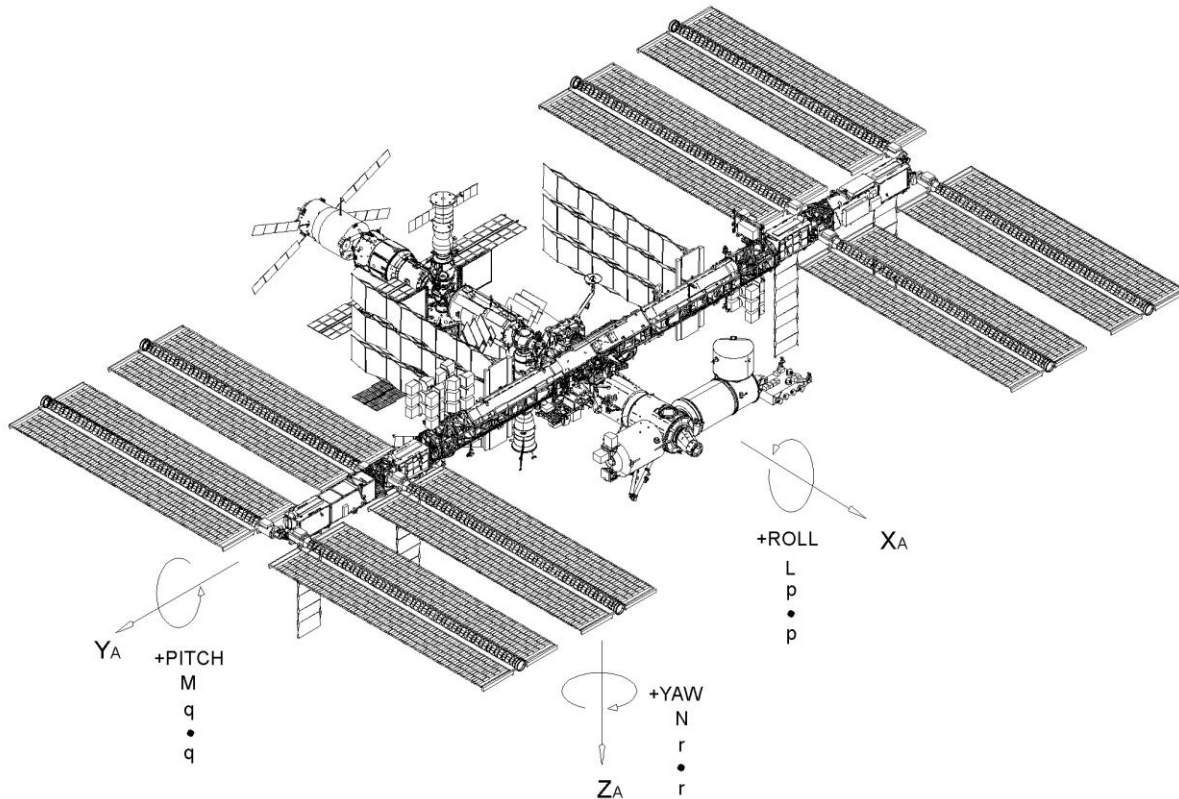
**FIGURE 3.1.5-1 ISS GN&C SYSTEM**

The LVLH reference frame is illustrated in Figure 3.1.5-2, LVLH Reference.



**FIGURE 3.1.5-2 LVLH REFERENCE**

ISS flies in the LVLH orientation in the orientation of the ISS X axis in the velocity vector (+XVV) 75% of the time. This memo is considering this flight regime only. Other attitudes, such as  $-XVV$ ,  $\pm YVV$ , or inertial J2000 are not considered. The ISS Analysis Coordinate System is defined in SSP 30219, Space Station Reference Coordinate Systems,<sup>25</sup> and is shown in Figure 3.1.5-3, ISS Dynamic References.



**FIGURE 3.1.5-3 ISS DYNAMIC REFERENCES**

The ISS can fly in various attitude control modes. The most common operational mode is the Torque Equilibrium Attitude (TEA) control utilizing a non-propulsive attitude controller and the payload should be prepared to operate in this environment. This mode provides the largest deviations from an Earth reference system (nadir viewing) and is therefore the most critical for payload operation. Propulsive control holds the commanded attitude to within  $0.625^\circ$ . U.S. CMG control has different characteristics depending on which controller type is being used, and the design of the particular controller. Typically, a momentum manager (MM) controller is flown during time periods in between thruster control. This MM control period usually lasts several weeks in between visiting vehicle dockings/undocking or berthings/unberthings and is referred to as quiescent operations. The MM controllers minimize momentum by allowing the attitude to 'wobble' around the TEA. Attitude hold controllers are not used during steady state quiescent operations, but these controllers minimize attitude variations at the expense of momentum usage. There are also hybrid controllers that can be used during quiescent operations that allow some momentum usage to reduce the attitude motions of the momentum manager minimization controllers.

During quiescent operations, the ISS solar panels are typically in auto-sun-tracking mode. Parked solar arrays significantly affect the aerodynamic torques, hence drastically influencing and changing the controller performances and TEAs. Controller performance specifications only apply during steady state quiescent operations of MM control. Steady state is defined as the time period when control parameters, such as attitude, rate, CMG momentum, have stabilized and converged to their final states. It



typically takes about 3 orbits for MM controller to reach state from the time they start running or after a disturbance. Disturbances are events such as stopping or starting solar panels, vents, depress event, or plume events. Controller performance during visiting vehicle proximity operations such as during dockings/undocking or berthings/unberthings and other special non-quiescent operations, including disturbance events induced by payloads, are not considered.

Significant change in ISS inertia or aerodynamic properties could adversely impact MM controller performance. Changes in atmospheric density due to solar storms, solar flares, or solar cycles could also impact MM performance.

### ISS +XVV TEA Ranges

Table 3.1.5-1, TEA Ranges And Typical/Predicted Performance, includes the +XVV attitude controller TEA envelope specifications for different solar beta ranges and predicted TEA ranges based on current ISS assembly complete configurations. These TEA ranges represent orbit average attitudes and the operators will command a target within this range. The TEA ranges do not take into account ranges of instantaneous attitude excursions or oscillations cited in the section regarding the controller performance. Both these average ranges below, and the instantaneous ranges due to the controller, must be superimposed to determine the total worst case attitude swing. Note that the predicted performance numbers are based on the assumptions outlined about (+XVV only, flying the TEA, solar panels auto tracking, quiescent steady state of MM control, nominal conditions). Figure 3.1.5-4, Natural TEA Ranges, includes Natural TEA Ranges.

		Attitude in YPR Euler Sequence			Attitude in YPR Euler Sequence						
		Roll (deg)	Pitch (deg)	Yaw (deg)			Roll (deg)	Pitch (deg)	Yaw (deg)		
ISS Config	Post-PMM Relocation/Pre-MLM										
Flight Regime	+XVV	Max	0.8	2.5	-2.9	Flight Regime	+YVV	Max	1.3	2.9	-92.5
		Min	0.6	-4.0	-4.1			Min	0.6	-4.1	-94.6
Flight Regime	-XVV	Max	0.8	3.0	177.2	Flight Regime	-YVV	Max	1.1	2.9	87.6
		Min	0.6	-3.5	176.0			Min	0.4	-4.1	86.4
ISS Config	Post-MLM/Pre-RS-NM										
Flight Regime	+XVV	Max	0.9	-1.7	-3.5	Flight Regime	+YVV	Max	1.4	-1.5	-93.3
		Min	0.7	-9.0	-5.1			Min	0.6	-9.4	-95.7
Flight Regime	-XVV	Max	0.9	-1.5	176.6	Flight Regime	-YVV	Max	1.2	-1.5	87.1
		Min	0.7	-8.7	175.0			Min	0.5	-9.5	85.5
ISS Config	Post-RS-NM/Pre-SPM										
Flight Regime	+XVV	Max	1.0	-2.9	-3.7	Flight Regime	+YVV	Max	1.5	-2.6	-93.4
		Min	0.7	-10.9	-5.3			Min	0.6	-11.4	-96.0
Flight Regime	-XVV	Max	1.0	-2.6	176.4	Flight Regime	-YVV	Max	1.3	-2.6	87.0
		Min	0.7	-10.6	174.7			Min	0.5	-11.4	85.3
Notes:											
Pedigree of natural TEAs											
- Natural TEAs were generated with port and starboard solar arrays (SARs/BGAs) auto-tracking											
- All 16 possible Russian visiting vehicle combinations/permutations on the 4 Russian ports were included in the TEA generation											
- All possible combinations/permutations of HTV, Dragon, & Cygnus cargo vehicles on Node1-nadir & Node2-nadir ports were included											
- Crewed visiting vehicle attachment to Node2 forward/zenith ports were NOT included in the TEA generation											
- Russian Science Power Module (SPM) was NOT included in the TEA generation											
Key Words: PMM - Permanent Multi-Purpose Module; MLM = Russian Multi-Logistics Module; RS-NM = Russian Node Module											

FIGURE 3.1.5-4 NATURAL TEA RANGES

TABLE 3.1.5-1 TEA RANGES AND TYPICAL/PREDICTED PERFORMANCE

Parameter	ISS Requirement	Typical/Predicted Performance
TEA envelope for solar beta < -65°	Yaw: -7° to 15° Pitch: -20° to 15° Roll: -15° to 15°	Yaw: -7° to 0° Pitch: -10° to 2° Roll: -1.5° to 1.5°
TEA envelope for solar beta ≥ -65° and ≤ 65°	Yaw: -15° to 15° Pitch: -20° to 15° Roll: -15° to 15°	Yaw: -7° to 0° Pitch: -10° to 2° Roll: -1.5° to 1.5°
TEA envelope for solar beta > 65°	Yaw: -15° to 7° Pitch: -20° to 15° Roll: -15° to 15°	Yaw: -7° to 0° Pitch: -10° to 2° Roll: -1.5° to 1.5°

Table 3.1.5-2, Attitude and Rate Controller Requirements and Predicted Performance, lists the controller requirements and typical or predicted performance. Please note that the predictions are based on: +XVV only, flying in TEA, quiescent steady state, and nominal conditions.

**TABLE 3.1.5-2 ATTITUDE AND RATE CONTROLLER REQUIREMENTS AND PREDICTED PERFORMANCE**

Parameter	Requirement	Typical/Predicted Performance	
Non Micro Gravity Attitude Control about the TEA (Assembly Stages)	Yaw $\pm 5^\circ$ Pitch $\pm 5^\circ$ Roll $\pm 5^\circ$	Momentum minimization controller	Yaw $\pm 1^\circ$ Pitch $\pm 1.25^\circ$ Roll $\pm 0.75^\circ$
		Attitude minimization controller	Yaw $\pm 0.13^\circ$ Pitch $\pm 0.25^\circ$ Roll $\pm 0.75^\circ$
		Blended controller	Yaw $\pm 0.5^\circ$ Pitch $\pm 0.88^\circ$ Roll $\pm 0.75^\circ$
Micro Gravity Attitude Control about the TEA (Assembly Complete)	Yaw $\pm 3.5^\circ$ Pitch $\pm 3.5^\circ$ Roll $\pm 3.5^\circ$	Same as above	
Attitude rate: non micro gravity	$\pm 0.02^\circ/\text{sec}/\text{axis}$	$\pm 0.005^\circ/\text{s}/\text{axis}$	
Attitude rate: micro gravity	$\pm 0.002^\circ/\text{s}$	New controllers will be designed when microgravity is invoked	

ISS GN&C Navigation and Attitude Knowledge Performance Specifications and Predicted Performance

Table 3.1.5-3, ISS Position and Attitude, indicates the ISS GN&C navigation knowledge performance specifications and predicted performance. Note that the predicted performance numbers are based on the assumptions outlined about (+XVV only, flying the TEA, solar panels auto tracking, quiescent steady state of MM control, nominal conditions).

**TABLE 3.1.5-3 ISS POSITION AND ATTITUDE**

Parameter	Requirement	Typical/Predicted Performance	
Attitude knowledge at navigation base (S0 truss) <sup>1</sup>	0.5°/axis 3σ	≤ 0.25°/axis 3σ	
Attitude knowledge on the non-articulated portion of the ISS <sup>2</sup>	3.0°/axis 3σ	≤ 1.0°/axis 3σ	
Rate knowledge	0.01°/s/axis 3σ	0.001°/s/axis 3σ	
Orbital position knowledge (non re-boost)	3000 ft 3σ	150 ft root mean square	
Orbital velocity (non re-boost)	No requirement	0.23 ft/s root mean square	
Orbital semi major axis knowledge	1000 ft 3σ	50 ft, root mean square	
Broadcast time error	± 5 milliseconds	Auto-sync (not typically used yet)	Manual sync – typically used
		≤ 55 microseconds	≤ 1 second

<sup>1</sup>Includes sensor accuracy errors, position measurement errors while converting inertial to LVLH attitudes

<sup>2</sup>Includes NAV base error, structural misalignment, and thermal bending and flex effects

Discussion and Use of the Broadcast Time Parameter Unique Identifiers (PUIs)

Broadcast time is the time broadcast from ISS computers that is intended to be indicative of current time. This is NOT the timestamp associated with state vector and attitude data. Broadcast time is available, and can be used to correct the broadcast time such that the corrected time stamp is accurate to within ±55 microseconds. In summary, Corrected Time – Broadcast time = Time Error.

The time functionality on ISS was intended to use an auto-sync feature such that the central computer on the ISS, the C&C computer, would sync its clock to the time output from the Global Positioning System (GPS) receiver in the SIGIs. However, due to various reasons, the C&C computer clocks are allowed to drift with respect to the Spacecraft Integrated GPS/Inertial Navigation System (INS) (SIGI) time by up to ± 1 second. The operators adjust a drift compensation parameter to adjust the C&C clock to keep the error to within 1 second. All other ISS computers sync to the C&C computer, and each ISS computer provides a time stamp for all data messages and a broadcast time via SubAddress 29 (reference SSP 41175-02, Software Interface Control Document Station Management and Control to International Space Station Book 2, General Software Interface Requirements).<sup>36</sup> That time stamp will also be in error by ±1 second. However, the GN&C computer calculates the time error of the C&C computer as compared to the SIGI GPS time and provides that time error in Broadcast Ancillary Data (BAD) data. The time stamp of each data packet can be adjusted by adding the time error to create a time stamp that is accurate to within ±55 microseconds. The broadcast time message is with respect to the GPS time scale, not the Universal Time Coordinated (UTC) time scale. Table 3.1.5-4, Broadcast Time

Description, provides Broadcast Time Descriptions, as contained in the SSP 41175-02.<sup>36</sup> (Please refer to this document for a list of PUIs.)

**TABLE 3.1.5-4 BROADCAST TIME DESCRIPTION**

Word #	Description	
	PUI = PD24482	
1	CCSDS Preamble field '01010000'B	Most significant 8 bits of BCD Year field, range 19-20
2	Least significant 8 bits of BCD Year field, range 0-99	BCD Month field, 8 bits, range 1-12
3	BCD Day of Month field, 8 bits, range 1-31	BCD Hours field, 8 bits, range 0-23
4	BCD Minutes field, 8 Bits, range 0-59	BCD Seconds field, 8 Bits, range 0-59
5	Spare, 12 bits	Binary Subseconds Most Significant 4-bits
6	Binary Subseconds continued - least significant 16 Bits, total range = 0 to 1,048,575 at one microsecond per count	
7	UTC Conversion Parameters, 16 bits, range 0-65,535 Always set to zero. Note this data is contained in Broadcast Ancillary Data	
8	Non CCSDS Seconds/Subseconds, 16 bits, range 0-65,535 The one's portion of the seconds plus the subseconds information of the CCSDS time converted to a straight binary count rounded to the nearest 256 microseconds (LSB = 256 μsecs)	

In addition, the time distribution of ISS attitude and ephemeris state knowledge is contained in Table 3.1.5-5, Time Distribution of ISS Attitude and Ephemeris State Knowledge and Control Data and Table 3.1.5-6, Specifications and Predictions of Attitude Rates, provides specifications and predictions of attitude rates.

**TABLE 3.1.5-5 TIME DISTRIBUTION OF ISS ATTITUDE AND EPHEMERIS STATE KNOWLEDGE AND CONTROL DATA**

Parameter	ISS Requirement	Typical/Predicted
Attitude, Position & Timestamp Broadcast Frequency	1 Hz	1 Hz
Broadcast Timestamp Error ±5 milliseconds	Auto-sync (not typically used)	Manual sync (typically used)
	≤ 0.03 milliseconds	≤ 1 seconds

**TABLE 3.1.5-6 SPECIFICATIONS AND PREDICTIONS OF ATTITUDE RATES**

Parameter	Micro-G Spec	Prediction	
Attitude Rate (deg/sec/axis)	±0.002	±0.02	≤ ±0.005
Attitude Rate (arcsec/sec/axis)	±7.2	±72	≤ ±18

Data Available in Broadcast Ancillary Data (BAD) for Payload Use

BAD data is defined in SSP 50540, Software Interface Definition Document Broadcast Ancillary Data.<sup>40</sup> SSP 50540, Appendix C<sup>40</sup> contains a representative list of GN&C parameters included in the BAD.

BAD is sent at 10 Hz to all RTs as described in Paragraph 3.3.2.2.3 of SSP 41175-02.<sup>36</sup> Two 32-word messages are broadcast during each 100 ms frame to each and every Remote Terminal (RT), to two consecutive subaddresses (#13 and #14) as shown in Table 3.2.3.2.1.4-1, Subaddress Assignments. Each 64-word transfer of BAD contains a 10-Hz, 1-Hz, and 1/10-Hz data segment. The first eight words contain the Consultative Committee for Space Data Systems (CCSDS) header and comprise the 10-Hz segment. The next 36 words comprise the 1-Hz segment, and the last 20 words comprise the 1/10-Hz segment. Transmission of the complete set of BAD repeats every 10 seconds. Parameters contained in the 100 separately defined Broadcast Ancillary Data packets is contained in Appendix A of SSP 41175-02.<sup>36</sup>

A Broadcast Frame Count (BFC) in the range of 0.99 is contained as word #8 of the CCSDS header. RTs requiring access to BAD should use the BFC to decommutate the data. It should be noted that the BFC contained in the BAD and the Frame Count contained in Broadcast Sync with Data may have different values, and thus the reason for decommutating the BAD based upon its own BFC.

It should be noted that the ISS typically flies several weeks in a row, in between dockings/undocking or berthings/unberthings, in quiescent operations with no thruster firings. The microgravity mode requirements are as follows:

- Maintain non-propulsive control for 30 continuous days
- Provide a total of 180 days/year of microgravity

Position and velocity data are provided to users on board ISS in feet and feet/sec, in telemetry in km and m/sec for the Conventional Terrestrial Reference System (CTRS) position and velocity, and in telemetry in meters and m/s for the inertial J2000 position and velocity. The CTRS is WGS84 (World Geodetic Survey of 1984 – the CTRS frame used by Global Positioning System). The Rotation, Nutation, Precession (RNP) matrix used by GN&C is available if needed. It is suggested that payloads use the CTRS information to avoid having to apply the particular RNP matrix being used by ISS GN&C.

### 3.2 ENVIRONMENTS APPLICABLE TO ALL ISS EXTERNAL SITES

#### 3.2.1 MICROGRAVITY ENVIRONMENT

The mechanical vibrations generated from all of the ISS systems are transmitted throughout the structure, and may affect experiments sensitive to acceleration. Attached payloads are required to restrict their mechanical vibrations so as not to disturb sensitive experiments while the ISS is in microgravity mode. To assure that payloads are able to survive these mechanical vibrations, payloads shall be designed to withstand the on-orbit vibration environment in Table 3.2.1-1, On-Orbit Random Vibration Environment. Please note that during nominal operating conditions, additional safety critical loads requirements are levied through ELC ICD.

**TABLE 3.2.1-1 ON-ORBIT RANDOM VIBRATION ENVIRONMENT**

Frequency (Hz)	Level
10–50	0.0005 g <sup>2</sup> /Hz
50–100	+3 dB/oct
100–1000	0.001 g <sup>2</sup> /Hz
1000–2000	–3 dB/oct
2000	0.0005 g <sup>2</sup> /Hz
Composite	1.3 grms
Duration	10 hr/year

Note: Accelerations must be evaluated as acting one axis at a time in each of three orthogonal axes.

#### Microgravity Disturbances

Microgravity disturbances induced by external payloads are separated into the three categories; quasi-steady for frequencies below 0.01 Hz; vibratory for frequencies between 0.01 Hz; and 300 Hz and transients. These requirements are defined to limit the disturbances to the microgravity environment of other payloads during microgravity mode periods and are not applicable during servicing, crew activities, maintenance, and reconfiguration. The microgravity disturbances induced by the external payload are not applicable during servicing, crew activities, maintenance, and reconfiguration. The microgravity environment induced by the external payload must not exceed the following levels.

#### Quasi–Steady Requirement

For frequencies below 0.01 Hz, payloads shall limit unbalanced translational average impulse to generate <10 lbs (44.5 N–s) within any 10- to 500-second period, along any ISS coordinate system vector.

#### Vibratory Requirement

For frequencies between 0.01 and 300 Hz, payloads shall limit vibration as defined in Paragraph 3.1.3.2.6.2.1 of SSP 57003-ELC, Attached Payload Interface Requirements Document – Expedite the Processing of Experiments to Space Station (EXPRESS) Logistics Carrier (ELC) Cargo Interface Requirements.<sup>44</sup>

Transient Requirements

1. Payloads shall limit force applied to the ISS over any 10-second period to an impulse  $\leq 10$  lbs (44.5 N-s).
2. Payloads shall limit their peak force applied to the ISS to  $< 1000$  lbs (4448 N) for any duration.

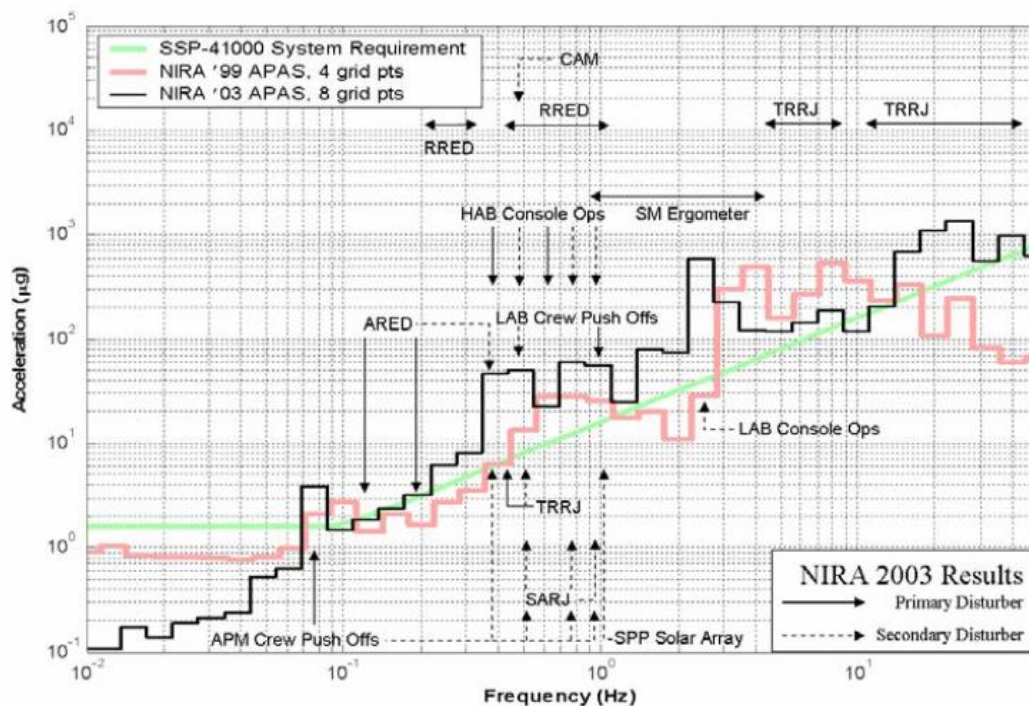
Meeting the above transient requirements does not obviate the need to also meet the 100-second vibration requirement for vibration included in and following the transient disturbance.

Microgravity Environment Profiles for ELC, JEM-EF, and Columbus-EF

Figures 3.2.1-1, Typical ELC Microgravity Environment depicts typical microgravity environment profiles for the ELC/ITA location on ISS.

Figure 3.2.1-2, Typical Microgravity Environment for JEM-EF depicts a typical microgravity environment profile for the JEM-EF external site.

Figure 3.2.1-3, Columbus Microgravity Environment depicts a typical microgravity environment profile for the Columbus location on ISS.



**FIGURE 3.2.1-1 TYPICAL ELC MICROGRAVITY ENVIRONMENT**



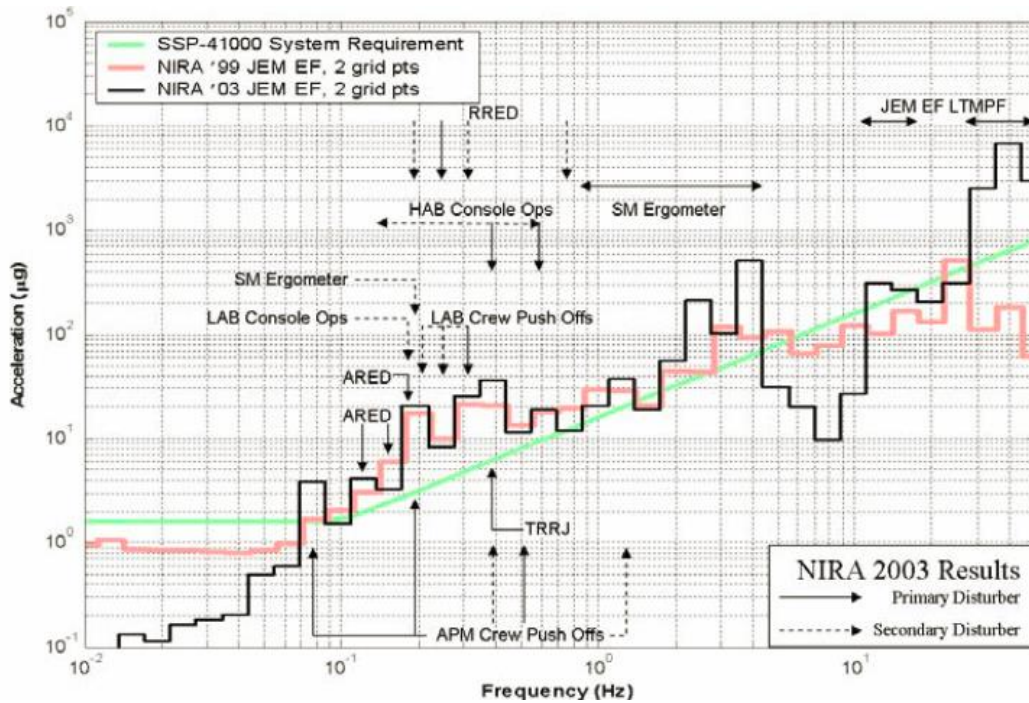


FIGURE 3.2.1-2 TYPICAL MICROGRAVITY ENVIRONMENT FOR JEM-EF

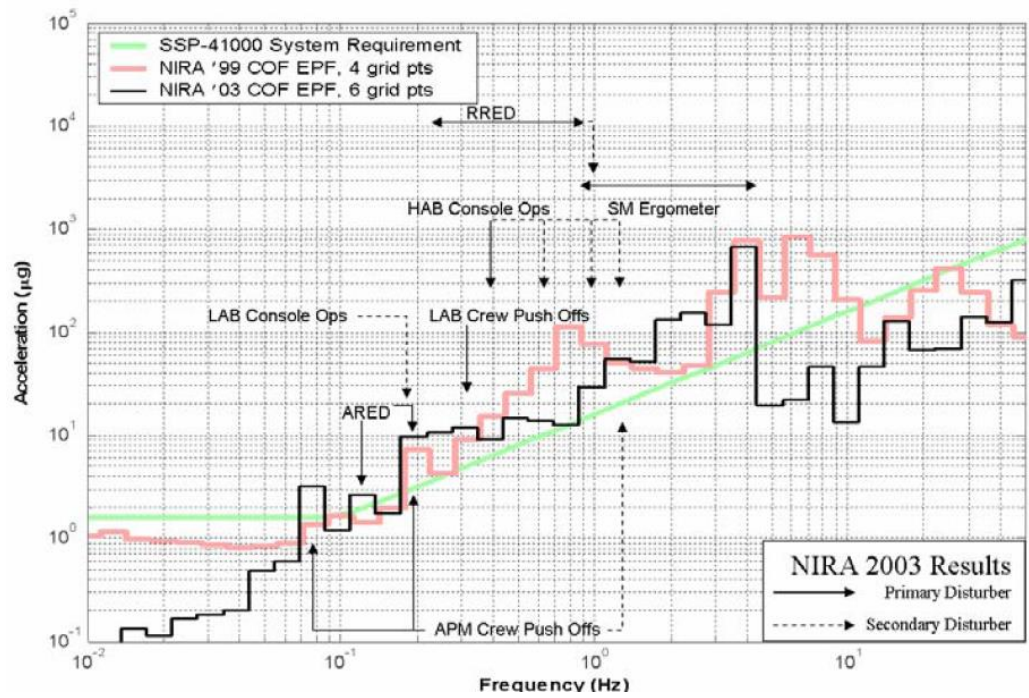


FIGURE 3.2.1-3 COLUMBUS MICROGRAVITY ENVIRONMENT

### 3.2.2 MICROMETEORIODS/ORBITAL DEBRIS

Impacts from micrometeoroids may cause permanently degraded performance or damage to the hosted payload instrument. This guidance provides estimates of the micrometeoroid particle size and associated flux in low-Earth orbit at an altitude of 400

km. The data comes from the Grün flux model assuming a micrometeoroid mean velocity of 20 km/s and a constant average particle density of 2.5 g/cm<sup>3</sup>.

Micrometeoroid and artificial space debris flux guidelines are provided separately due to the stability of micrometeoroid flux over time, compared to the increase of artificial space debris. Figure 3.2.2-1, Artificial Space Debris Environment, contains the micrometeoroid and space debris flux.

Impacts from artificial space debris may permanently degrade performance or damage the Instrument. This guidance estimates the artificial space debris flux and impact velocities an Instrument can expect to experience during the Calendar Year 2014 epoch. Expected artificial space debris flux increases over time as more hardware is launched into orbit. This analysis is for an altitude of 400 km and an orbital inclination of 51.65 degrees.

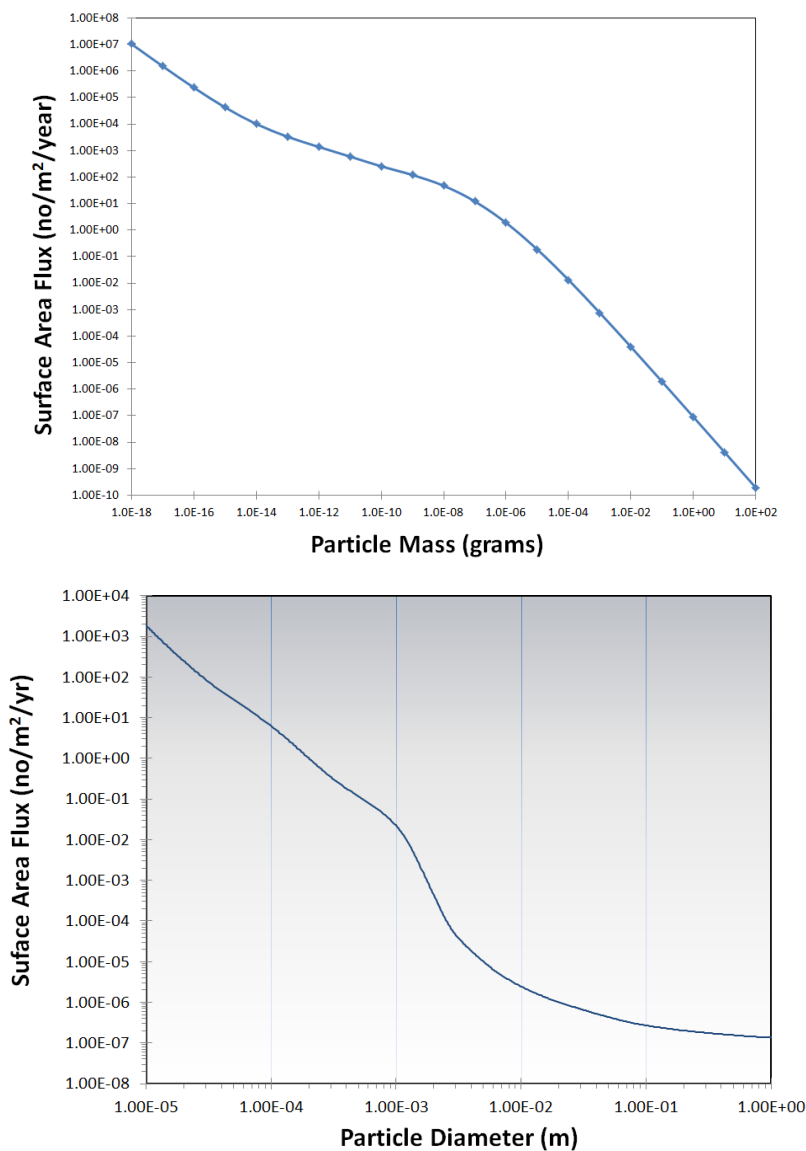


FIGURE 3.2.2-1 ARTIFICIAL SPACE DEBRIS ENVIRONMENT

### 3.2.3 MAGNETIC FIELD AND GRAVITATIONAL FIELD

The natural on-orbit electromagnetic field and gravitational field environments to which ISS payloads will be exposed are defined in SSP 30425, Space Station Program Natural Environment Definition For Design - International Space Station Alpha.<sup>31</sup> However, these forces will not be a major factor to the proposer, in all probability. Therefore, no further data are presented in this Guide.

### 3.2.4 ATOMIC OXYGEN

The average Atomic Oxygen flux of  $5.0 \times 10^{21}$  atoms/cm<sup>2</sup>/year is expected for the external payload locations. Surfaces exposed 30 days or less will be exposed to an average of  $4.4 \times 10^{19}$  atoms/cm<sup>2</sup>/day.

### 3.2.5 ON-ORBIT MINIMUM PRESSURE ENVIRONMENT

Payload proposers should plan for their externally integrated and mounted payloads to be able to survive an on-orbit minimum pressure environment of  $1.0 \times 10^{-7}$  Torr ( $1.333 \times 10^{-5}$  Pa).

### 3.2.6 SPACE SINK TEMPERATURE

External payloads will be exposed to and must be compatible with a space sink temperature of 3 K.

### 3.2.7 ELECTROMAGNETIC RADIATION (EMR)

Electromagnetic noise sources of significance at the ISS extend from direct current to X-ray. Only natural and remote human-made EMR sources are considered here. The categories of noise producers are as follows: Galactic, Solar, Near-Earth natural plasma, and human-made radio noise.

The highest power densities expected to be irradiating the ISS are from the solar radiation in the ultraviolet and visible portions of the electromagnetic spectrum. The ultraviolet radiation can damage materials exposed to it. SSP 30426, Space Station External Contamination Control Requirements, Paragraph 7.2,<sup>32</sup> describes the degree of exposure of the payloads to the solar ultraviolet radiation environment. Other effects of EMR to be considered include radio noise and field strengths from the natural sources at the ISS. Field strengths produced from quasi-static field structures in the plasma have typical values around 25 mV/m, but can be larger. These values generally occur at latitudes greater than 50°.

### 3.2.8 CONTAMINATION

The ISS has been designed and built with strict contamination control requirements to provide low levels of induced contamination on external payload assets. The ISS contamination environment is one to two orders of magnitude (10 to 100 times) better than the environment provided by the Mir Space Station. This has been demonstrated by both flight experiments and measurements made on returned hardware.

In order to fly on ISS, payloads must demonstrate compliance with ISS contamination control requirements. The SSP 41000, System Specification for the International Space Station,<sup>35</sup> contains the top-level requirements (ISS system level requirements). SSP 41000, Paragraph 3.2.6.1.3<sup>35</sup> (which calls on SSP 30426, Paragraphs 3.4 and 3.5)<sup>32</sup>

specifies the “design-to” contamination environment of 130 Å/year on contamination sensitive surfaces. Payloads should be designed to perform within this contamination environment.

SSP 41000, Paragraph 3.3.10.3<sup>35</sup> (which calls on SSP 30426, Paragraphs 3.4, 3.5 and 3.6)<sup>32</sup> specifies the external contamination releases requirement which limit contaminant deposition to 130 Å/year on contamination sensitive surfaces, from all sources of contamination on the vehicle combined (ISS elements, visiting vehicles and payloads). Hence, the contaminant deposition contribution from a new payload, when combined with contributions from all sources (ISS elements, visiting vehicles and payloads), must not exceed 130 Å/year on contamination sensitive surfaces of ISS, visiting vehicles and other external payloads. This requirement is verified by analysis by the ISS Program. The PD is responsible for preparing and submitting a characterization of contaminant sources on the payload as required input to the system level analyses conducted by the ISS Program.

In addition to compliance with the ISS system level contaminant release requirements, payloads are required to comply with specific contaminant releases allocations governing integration at specific sites (U.S. Segment attached payload sites, ELCs, the Columbus-EPF and the JEM-EF). As in the case of system level verification, the payload is responsible for preparing and submitting a characterization of contaminant sources on the payload. The intra-site integration analyses are conducted by the site integrator.

Payloads designed for deployment on the U.S. Segment payload sites must comply with contamination requirements detailed in SSP 57003, External Payload Interface Requirements Document,<sup>43</sup> SSP 57003-ELC (for ELC-based payloads), Attached Payload Hardware Interface Control Document Template,<sup>44</sup> SSP 57004, Attached Payload Interface Control Document Express Logistics Carrier (ELC) Cargo Interface Control Document Template,<sup>45</sup> SSP 57004-ELC (for ELC-based payloads),<sup>46</sup> and SSP 57011, Payload Verification Program Plan.<sup>47</sup>

Requirements governing integration and verification of payloads on the European Columbus Module are specified in the COL-RIBRE-SPE-0165, Columbus External Payloads Interface Requirements Document.<sup>4</sup>

Payloads flying on the JEM-EF are governed by the NASDA-ESPC-2563, JPAH Vol. 3, Exposed Facility/Payload Standard Interface Control Document.<sup>16</sup> JEM-EF requirements specify compatibility with the ISS system level requirements but do not make specific sub-allocations for payload-to-payload induced contamination level within the JEM-EF.

As previously stated, PDs are required to deliver a characterization of contamination sources on their payloads to support integration and requirements verification activities conducted by the Program. Characterization of payload contamination sources include definition of vacuum exposed materials (all non-metallic materials outside of a pressurized or hermetically sealed environment), vacuum venting (liquids and gases), leakage, thrusters, and sources of particulate releases. PDs are also requested to identify payload contamination-sensitive surfaces and provide operating temperature predictions (contaminant deposition is highly dependent on the operating temperature of

receiver surfaces). This information is used for tracking-induced contamination on the payload from the vehicle (ISS), visiting vehicles, and other payloads.

Payload data deliveries covering for non-metallic vacuum exposed materials must include identification of materials, location of material application on payload (if application is localized), vacuum-exposed surface area, nominal operating temperature range, and outgassing rate data (ASTM E1559, Standard Test Method for Contamination Outgassing Characteristics of Spacecraft Materials).<sup>2</sup> The preferred format for the definition of operating temperature data for payload materials is one that specifies the percentage of time spent under 30 °C, between 30 °C and 60 °C, and between 60 °C and the maximum operating temperature. Outgassing rate test data for the ISS Program is based on Method B of the ASTM E1559<sup>2</sup> standard, with a minimum test duration of 144 hours and four Thermally controlled Quartz Crystal Microbalances (TQCMs) used for condensable outgassing rate measurements (TQCMs at 80 K, -40 °C, -10 °C and +25 °C).

The PD is required to deliver a preliminary characterization of contamination sources verification by 24 months prior to launch (L-24 months). The preliminary data delivery at L-24 months is used to identify potential issues and allow for corrective action with minimal impacts to cost and schedule of payload development and integration. Updates to the preliminary data delivery are required if significant sources of contamination (or significant changes) are introduced prior to final data delivery.

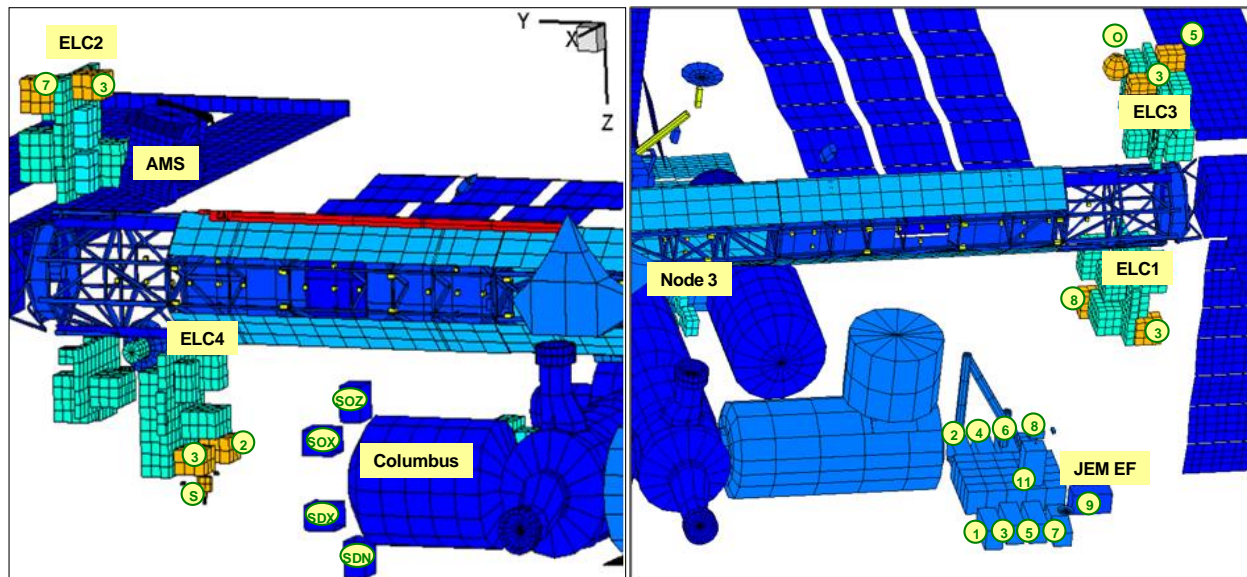
Final verification data submittal from the payload is required 7.5 months prior to launch (L-7.5 months). The final analysis report supporting verification (conducted by the Program) is issued by L-3 months.

From experience from past and existing payloads, the most significant source of contamination from payloads is the use of high outgassing materials (non-metallics). It is critical to control and minimize the use of silicones (e.g., room-temperature vulcanizing (RTV) and continuous vulcanization (CV) series silicones, silicone-based thermal control paints, cable insulation, cable clamps, connectors, etc.) and hydrocarbon based materials (e.g., Velcro<sup>®</sup>, epoxies, conformal coatings, Tefzel<sup>®</sup> cable insulation and encapsulation). Control of outgassing venting paths can be effective in mitigating contamination induced by the payload and the Program can assist with determine preferential venting paths.

As part of ISS payload integration activities, contamination forecast maps are generated for U.S. attached payload sites to support payload feasibility, topology, and placement studies. Forecast maps are also used to identify potential integration issues of the ELC payload complement. These predictions are available to Payload Proposers upon request to the Program.

The ELC based attached payload sites are shown in Figure 3.2.8-1, Payload Mapping Sites (ELCS 1-4). Each ELC contains two payload sites in addition to a complement of ISS spares designated as ORUs. The ELC based payload sites are shown in orange in Figure 3.2.8-1. ORUs are shown in teal color (same as the ELC frame). The payload sites on ELCs 1-3 are located on opposing sides of the carrier ELC. ELC 4 offers two

payload sites on the same side (ISS inboard side). Figure 3.2.8-1 also shows the ISS coordinate system for reference purposes.



**FIGURE 3.2.8-1 PAYLOAD MAPPING SITES (ELCS 1-4)**

Contamination forecast maps for 2015–2017 are summarized in Tables 3.2.8-1 through 3.2.8-3. These predicted contamination levels were generated for generic payload envelopes, not actual payload geometries. These figures are meant to provide initial guidance for choosing payload locations. The Program will work with each payload to obtain more detailed predictions as their designs mature.

Contaminant deposition predictions are provided for three receiver operating temperatures (+25 °C, -10 °C and -40 °C). The blue cells represent payload envelope surfaces expected to receive less than 130 Å/year. Gray cells represent the payload interface surfaces with the ELC (the mounting surface). Red cells represent surfaces expected to receive greater than 130 Å/year.

The great majority of red cells are associated with potential contamination from an adjacent ORU on the ELC) and generally only for payload operating temperatures below -10 °C. Further, payload surfaces facing an adjacent ORU have an obstructed FOV (the ORU obstructs the view from that side) and are unlikely to contain contamination sensitive surfaces.

In the process of generating the contamination forecast maps, if a payload surface is identified as receiving deposition levels in excess of 130 Å/year, and is not associated with an adjacent ORU, that surface is identified for forward work (issue resolution).

**TABLE 3.2.8-1 2015 CONTAMINATION FORECAST MAP SUMMARY**

Payload Site	Contaminant Deposition on Payload Envelope Surfaces (Å/year)																	
	+X <sub>ISS</sub>			-X <sub>ISS</sub>			+Y <sub>ISS</sub>			-Y <sub>ISS</sub>			+Z <sub>ISS</sub>			-Z <sub>ISS</sub>		
	25°C	-10°C	-40°C	25°C	-10°C	-40°C	25°C	-10°C	-40°C	25°C	-10°C	-40°C	25°C	-10°C	-40°C	25°C	-10°C	-40°C
ELC1 - Site 3	9.8	29	67	36	51	74				2.1	3.3	7.3	12	14	18	21	41	98
ELC1 - Site 8	27	64	107	47	56	82	76	110	190				16	19	24	40	67	147
ELC2 - Site 3	6.7	17	33	43	71	86				24	41	76	24	57	98	0.1	0.2	0.3
ELC2 - Site 7	1.0	4.7	16	24	49	65	1.3	3.4	13				22	45	96	0.2	0.3	0.3
ELC3 - Site 3	1.9	16	151	49	69	114	22	38	110				49	99	324	0	0.1	0.1
ELC3 - Site 5	51	104	249	18	19	23				1.1	3.0	11	35	69	229	0.1	0.1	0.1
ELC4 - Site 2	31	57	206	57	68	92				72	102	168	17	21	28	37	58	209
ELC4 - Site 3	2.6	15	45	77	101	242				60	92	162	11.7	14	20	36	203	370

**TABLE 3.2.8-2 2016 CONTAMINATION FORECAST MAP SUMMARY**

Payload Site	Contaminant Deposition on Payload Envelope Surfaces (Å/year)																	
	+X <sub>ISS</sub>			-X <sub>ISS</sub>			+Y <sub>ISS</sub>			-Y <sub>ISS</sub>			+Z <sub>ISS</sub>			-Z <sub>ISS</sub>		
	25°C	-10°C	-40°C	25°C	-10°C	-40°C	25°C	-10°C	-40°C	25°C	-10°C	-40°C	25°C	-10°C	-40°C	25°C	-10°C	-40°C
ELC1 - Site 3	8.8	25	53	30	44	69				2.0	3.1	7.0	8	11	17	19	38	91
ELC1 - Site 8	24	57	92	34	47	79	55	93	174				9	13	22	37	62	135
ELC2 - Site 3	6.0	15	28	40	66	80				22	37	66	22	51	87	0.3	0.4	0.5
ELC2 - Site 7	0.7	3.7	12	22	46	60	1.2	3.2	12				20	42	88	0.4	0.5	0.5
ELC3 - Site 3	1.6	13	89	44	62	103	19	33	87				43	87	245	0	0.1	0.1
ELC3 - Site 5	46	92	220	16	17	22				1.1	2.8	11	31	62	207	0.2	0.2	0.2
ELC4 - Site 2	27	48	174	50	66	101				64	101	171	19	25	37	33	53	190
ELC4 - Site 3	1.2	10	27	67	96	236				52	90	160	12.5	16	24	33	169	317

**TABLE 3.2.8-3 2017 CONTAMINATION FORECAST MAP SUMMARY**

Payload Site	Contaminant Deposition on Payload Envelope Surfaces (Å/year)																	
	+X <sub>ISS</sub>			-X <sub>ISS</sub>			+Y <sub>ISS</sub>			-Y <sub>ISS</sub>			+Z <sub>ISS</sub>			-Z <sub>ISS</sub>		
	25°C	-10°C	-40°C	25°C	-10°C	-40°C	25°C	-10°C	-40°C	25°C	-10°C	-40°C	25°C	-10°C	-40°C	25°C	-10°C	-40°C
ELC1 - Site 3	8.0	16	38	29	42	62				1.9	3.0	6.6	9	11	15	18	35	85
ELC1 - Site 8	22	39	69	34	42	59	58	79	131				12	14	20	34	57	125
ELC2 - Site 3	5.7	14	26	37	60	73				20	34	61	21	48	81	0.3	0.4	0.4
ELC2 - Site 7	0.8	3.7	11	20	42	56	1.1	3.0	11				18	39	82	0.3	0.4	0.5
ELC3 - Site 3	1.4	9	70	40	56	94	18	29	76				40	75	208	0	0.1	0.1
ELC3 - Site 5	41	84	198	15	16	19				1.0	2.7	10	29	57	189	0.2	0.2	0.2
ELC4 - Site 2	25	46	162	46	56	77				60	87	141	18	22	29	31	48	174
ELC4 - Site 3	2.0	11	26	62	84	201				49	77	131	11.2	14	19	30	148	282

The contamination forecast maps offer insight into the system level contamination environment for ISS payloads, and support payload placement and topology studies. During the payload integration process, higher fidelity contamination analyses are conducted using actual payload geometries, materials and operating temperature data to support verification and to ensure success of science missions.

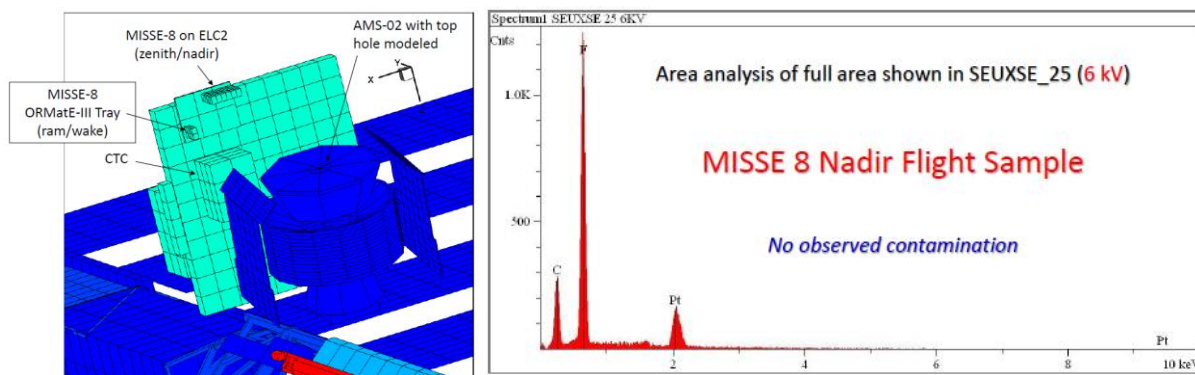
Contaminant deposition measurements have been made on returned hardware, and comparisons to analysis predictions have been made to assess performance against expectations. Predicted contamination levels at ISS payload sites are often lower than the system level specification for select surfaces and several contamination sensitive payloads have relied on predicted levels in operational planning. However, the Program recommends designing for performance within the system level specification of 130 Å/year.

Returned materials samples from the Materials International Space Station Experiment (MISSE) 2 flight experiment, which were exposed to the ISS contamination environment for 4 years (from 2001 to 2005), demonstrated low levels of induced contamination from U.S. Segment hardware on ram facing surfaces (wake facing surfaces received contamination from Russian Segment hardware). A comparison of the MISSE 2 predicted and measured contaminant deposition is shown in Table 3.2.8-4, Predicted Versus Measures Contaminant Deposition on MISSE 2.

**TABLE 3.2.8-4 PREDICTED VERSUS MEASURED CONTAMINANT DEPOSITION ON MISSE 2**

Experiment	Side	Predicted	Measured
MISSE 2	ram	80 Å	50 Å
	wake	730 Å	500 Å

In 2013, samples returned with the MISSE 8 flight experiment, which was deployed on ELC2 for 2 years, were analyzed with no identification of contaminant deposition. (Shown in Figure 3.2.8-2, MISSE 8 Configuration on ELC2 and Sample Surface Analysis Results.)



**FIGURE 3.2.8-2 MISSE 8 CONFIGURATION ON ELC2 AND SAMPLE SURFACE ANALYSIS RESULTS**

In summary, the ISS offers an exceptionally clean environment to attached payloads. The low levels of induced contamination on the vehicle can support a wide variety of contamination sensitive payloads observing in the visible, infrared, and ultraviolet regions.

### 3.2.9 IONOSPHERIC PLASMA EFFECTS AND SPACECRAFT CHARGING

The ionosphere consists of electrons, and ions (primarily O+). The ions and electrons are mostly disassociated by extreme ultraviolet solar radiation. These free charges make a highly electrically conductive plasma that is responsive to magnetic fields. Also, they make the ISS (and other spacecraft) subject to charging.

The ISS operates in the F2-region of the Earth's ionosphere (generally, a low-temperature high-density plasma). The primary influences on ISS charging (floating potential (FP) relative to the ionospheric plasma) are (1) the 160-V United States Orbital



Segment Solar Array Wings (that have been grounded negative), (2) the large capacitance of the ISS vehicle, (3) magnetic induction resulting from the motion of the ISS through the geomagnetic field (e.g., from truss-tip to truss-tip), and (4) the variability of the ionospheric environment. As the ISS passes from eclipse to insolation each orbit, the solar arrays collect charge and drive the ISS floating potential negative with respect to the surrounding plasma.

ISS potential varies with location on ISS due to magnetic induction. The highest potential differences (with respect to the surrounding plasma) occur at the locations that are the furthest from the vehicle centerline (with respect to the direction of motion). Figures 3.2.9-1, Ionesphere Reference Potential-1 and 3.2.9-2, Ionesphere Reference Potential-2, provide a representation of potential with respect to ionosphere reference potential. These induced potentials are supported by the flowing plasma outside the vehicle and do not appear in the conducting structure.

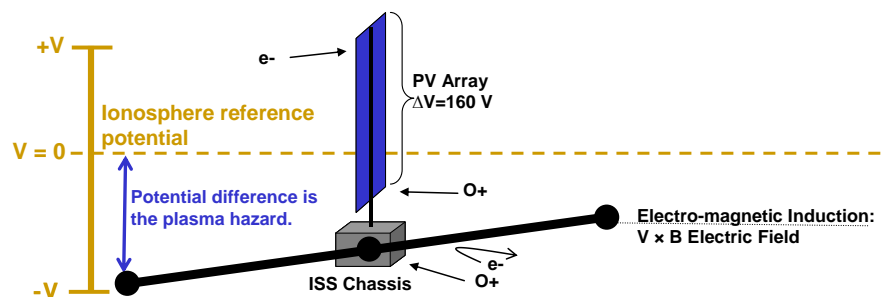


FIGURE 3.2.9-1 IONOSPHERE REFERENCE POTENTIAL-1

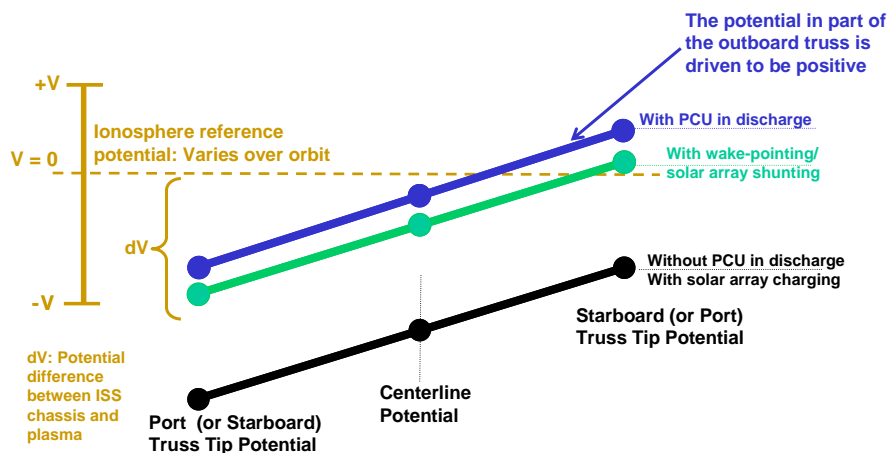


FIGURE 3.2.9-2 IONOSPHERE REFERENCE POTENTIAL-2

Before any new payload is added to the ISS external environment, it needs to meet the plasma requirements. In particular, the plasma requirements affect those payloads that are in direct contact with the plasma (vacuum exposed surfaces). The arcing potentials of the external materials (dielectric surfaces), and the electron and ion collection of external conducting materials, and any electric potential biasing produced by the payload must be considered. The plasma requirements address material breakdown voltages, payload induced current to ISS, and payload induced bias of the ISS structure floating potential.

Material Breakdown Voltages: The maximum expected floating potential of the Space Station structure is +20/−80 V for hardware located inboard of the Solar Alpha Rotary Joint (SARJ) and +20/−90 volts for hardware located outboard and including the SARJ. Attached payload external hardware shall ensure that their materials (including surface coatings) that are directly exposed to the defined plasma environment can operate within this range without material breakdown.

Payload Induced Current to ISS: The induced current to the ISS by any single attached payload shall be less than 0.25 mA.

Payload Induced Bias of ISS Structure Floating Potential: The operationally induced bias to the FP of the ISS structure by an attached payload/experiment shall be less than  $\pm 1$  V.

For the ISS, the required input data from the PD is listed in CVDS EL-06. The required input data are summarized here for convenience:

- Identify dielectric surfaces of potential concern for arcing in the ISS expected environment as specified in the requirement.
  - For those surfaces of potential concern, identify the material composition, surface area, capacitance, thickness, dielectric strength, location, and orientation
- Provide a background description of the attached payload/experiment, in particular, operations, and objectives.
- Provide general payload/experiment design data. In particular, including, as appropriate:
  - Electrical power system data
  - Grounding and bonding data
  - Solar array/cell data (i.e., I-V sweep)
  - Exposed material data (i.e., conducting metallic surface area, material breakdown voltage)

#### 4.0 EXTERNAL PAYLOAD SITES, ACCOMMODATIONS AND INTERFACES

This section provides more detailed information on each of the ISS external payloads sites. The introductory section is presented as a comparative summary in tabular format. In the subsequent paragraphs, each of the three ISS sites is presented in a more detailed fashion. Paragraph 4.1, Integrated Truss Assembly/ExPRESS Logistics Carrier (ITA and ELC, specifically), Paragraph 4.2, Japanese Experiment Module-External Facility (JEM-EF), and Paragraph 4.3, Columbus External Payload Facility (Columbus-EPF) contain information needed for your proposal effort, along with additional references, as may be needed. Section 3.0 contains accommodations and interfaces common to all three ISS external sites, e.g. Robotics, Microgravity Environment, Wireless Capability, Micrometeoroid/Orbital Debris, Magnetic Field and Gravitational Field, Electro-Magnetic Radiation, Ionizing Radiation, Contamination, Spacecraft Charging, Atomic Oxygen, Contingency EVA and End of Mission.

Table 4.0-1, ISS External Capabilities Comparison, contains a brief comparison of each of the ISS external sites, but is summary in nature. You may use this table for top-level discriminations between the three ISS external sites, which might help to determine the best site for your payload. More details for each external site are included in Paragraphs 4.1, 4.2, and 4.3. In addition, SSP 57021, Attached Payloads Accommodations Handbook,<sup>49</sup> provides a design-to level of information for your subsequent activities.

In addition, if it is necessary to waive or modify a requirement in your proposal that is determined to be vital to continuing with your proposal effort, please contact the Manager of ISS NASA Science and Technology Office or the point of contact named in the AO.

TABLE 4.0-1 ISS EXTERNAL CAPABILITIES COMPARISON

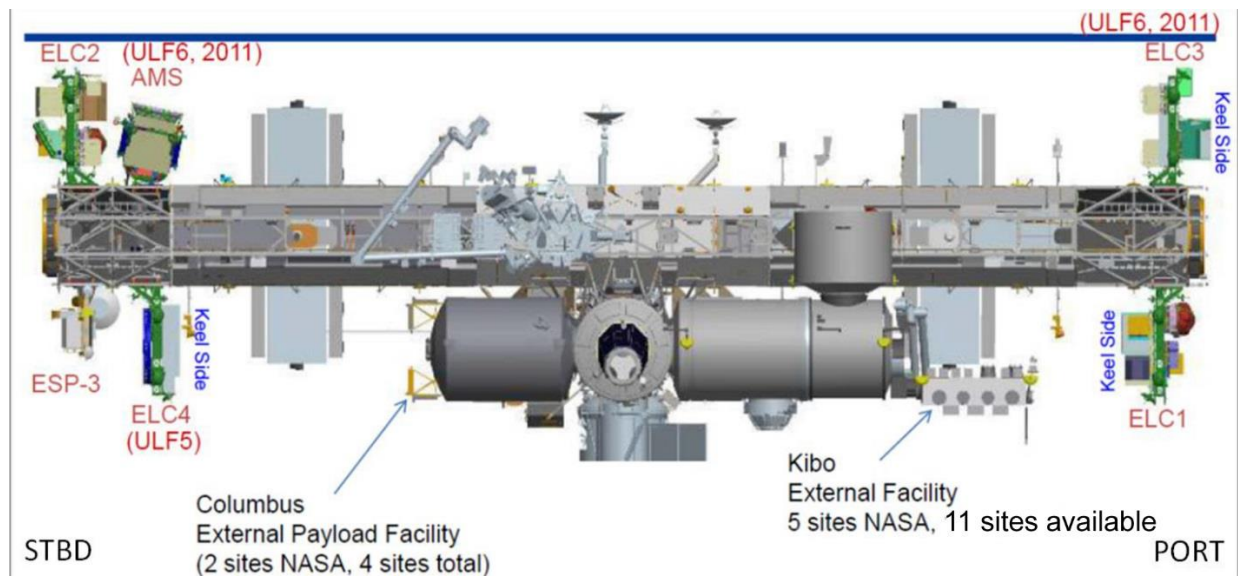
Service/Location	ELC/ExPRESS Payload Adapter (ExPA)	JEM-EF	Columbus-EPF
Payload Mass lbs [kg]	500 [226.8]	1100 [500] @ standard payload locations 5500 [2500] @ heavy payload locations	500 [230]
Payload Volume	34x46x49 (H, in.) or 1 m <sup>3</sup>	72.83x31.5x39.37 (H, in.) or 1.5 m <sup>3</sup>	34x46x49 (H, in.) or 1 m <sup>3</sup>
Thermal	Passive cooling, active heating (using PD-provided heating elements)	Active Cooling 3 kW @ standard-power locations, 6 kW @ high-power locations	Passive cooling, active heating (using PD-provided heating elements)
<b>Power</b>			
Operational Power (W)	750 @ 113-126 Vdc 500 @ 28 Vdc per ExPA (adapter)	3-6 kW, 113-126 Vdc*	2.5 kW total (shared) 113-126V between 2 feeds*
Survival Power watts	Primary/Secondary of 300 @ 106.5 to 126.5 Vdc each	120 W @ 110.5 to 126 Vdc Heater Power	1.2 kW @ 120±7 Vdc shared between the payload compliment
<b>Command &amp; Data Handling</b>			
Ethernet	One-way Ethernet (10 BASE T) link for downlinking ELC cargo science data.	Refer to MRDL	Refer to MRDL
Low-Rate Data Link (LRDL)	20 kbps (typical) telemetry downlink using MIL-STD-1553B <sup>14</sup>	20-kbps (typical) telemetry downlink using MIL-STD-1553B <sup>14</sup>	20-kbps (typical) telemetry downlink using MIL-STD-1553B <sup>14</sup>
High-Rate Data Link (HRDL)	N/A	User data rate determined by parsing the 100-Mbps encoded signaling rate with Sync symbols. One-way downlink only via optical interface.	32 Mbps maximum shared data rate in 32-kbps increments. Data rate determined by parsing the 100-Mbps encoded signaling rate with Sync symbols. One-way downlink only via optical interface.
Medium-Rate Data Link (Wired)	N/A	Wired Ethernet (10/100 BASE T) for downlink and two-way Ku-band communication	Wired Ethernet (10/100 BASE T) for downlink and two-way Ku-band communication
Wireless Data	10–50 Mbps per External Wireless Communication (EWC) Access Point (AP)	10–50 Mbps per EWC Access Point	10–50 Mbps per EWC AP
Sites for External Payloads	Four ELC providing eight sites for payloads (2 sites per ELC)	Five available to NASA	Two available to NASA

\* Note: Denotes resources are shared among payloads at that site (JEM-EF, Columbus)

## 4.1 INTEGRATED TRUSS ASSEMBLY/EXPRESS LOGISTICS CARRIER

### 4.1.1 INTRODUCTION

The ISS ITA provides unique opportunities for external payloads. The six sites are very valuable. One site is devoted to the Alpha Magnetic Spectrometer, since 2011, and one site is devoted to External Stowage Platform (ESP)-3. The four remaining sites are devoted to ELCs. The ELC was developed by NASA as a carrier that can be utilized by several payloads at each of the four truss locations and is designed to carry a variety of ORUs, or spares, first-time outfitting cargo, and external payloads (science experiments). The ELCs are located on the ISS ITA as depicted in Figure 4.1.1-1, ELC Locations on ISS. Fully integrated with mounted cargo/payloads, the ELC was delivered to the ISS via space shuttle and is a NASA-funded payload facility. External ELC payloads, replacing the payloads already on orbit, or utilizing unused ELC sites will now be delivered to the ISS on visiting vehicles, such as the Dragon spacecraft, which is launched currently by Falcon 9 v1.2.



**FIGURE 4.1.1-1 ELC LOCATIONS ON ISS**

The ELCs are located on both the port and starboard truss segments on the ISS and utilize the Mobile Remote Servicer Base System. ELC2 is starboard zenith, ELC4 is starboard nadir, ELC3 is port zenith, and ELC1 is port nadir. The ELC is one of the primary means of providing external accommodations to the science community. External payload proposers should evaluate the ELC as a potential accommodation site for their payload. For detailed design information, please refer to SSP 57003-ELC,<sup>44</sup> and SSP 57003.<sup>43</sup>

### 4.1.2 PHYSICAL ACCOMMODATIONS

There are four ELCs (ELC-1 through ELC-4) for use by PDs. Each ELC is equipped to carry two ExPAs, which serve as the physical and electrical (inclusive of data connectivity) interface to external payloads. The ExPA Plate is a single piece of mounting hardware integral to the Active Flight Releasable Attach Mechanism (AFRAM)

and the payload mounting provisions. The ExPRESS Payload Adapter (ExPA) Plate provides the mechanical and structural basis for the AFRAM assembly. The AFRAM serves as the attachment mechanism for connecting the ExPA (and your payload) to the Passive FRAM (PFRAM) that is already located on the ELC.

For further details regarding the ExPA, please refer to D683-97497-01, ExPRESS Payload Adapter (ExPA) Interface Definition Document (IDD).<sup>7</sup>

Details of the ELC locations are provided in Figures 4.1.2-1, ELC Location on ISS and 4.1.2-2, ELC Location on ISS. The ELCs provide a total of eight external payload hosting locations. Your external payload will physically mount on an ExPA, which in turn, will be mounted on an ELC.

Your payload is limited to the envelope defined in Figure 4.1.2-3, ExPA Payload Envelope. This is both the launch and on-orbit envelope.

Your payload volume is centered according to Figure 4.1.2-4, Generic ExPA Payload Coordinate System. This is both the launch and on-orbit envelope.

An illustration of the entire AFRAM and PFRAM adapter plate system is contained in Figure 4.1.2-5, AFRAM and PFRAM Expanded View (Note: AFRAM Adapter Plate and the AFRAM is Considered a Single Unit in an expanded view format. This arrangement is also referred to as the ExPA).

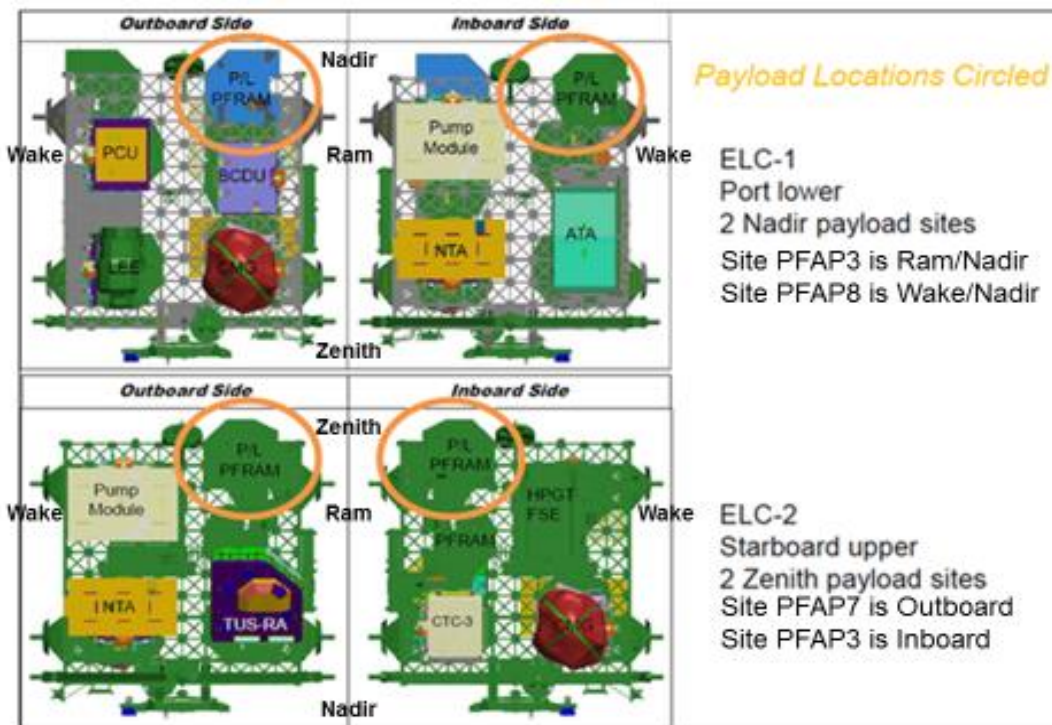


FIGURE 4.1.2-1 ELC LOCATION ON ISS

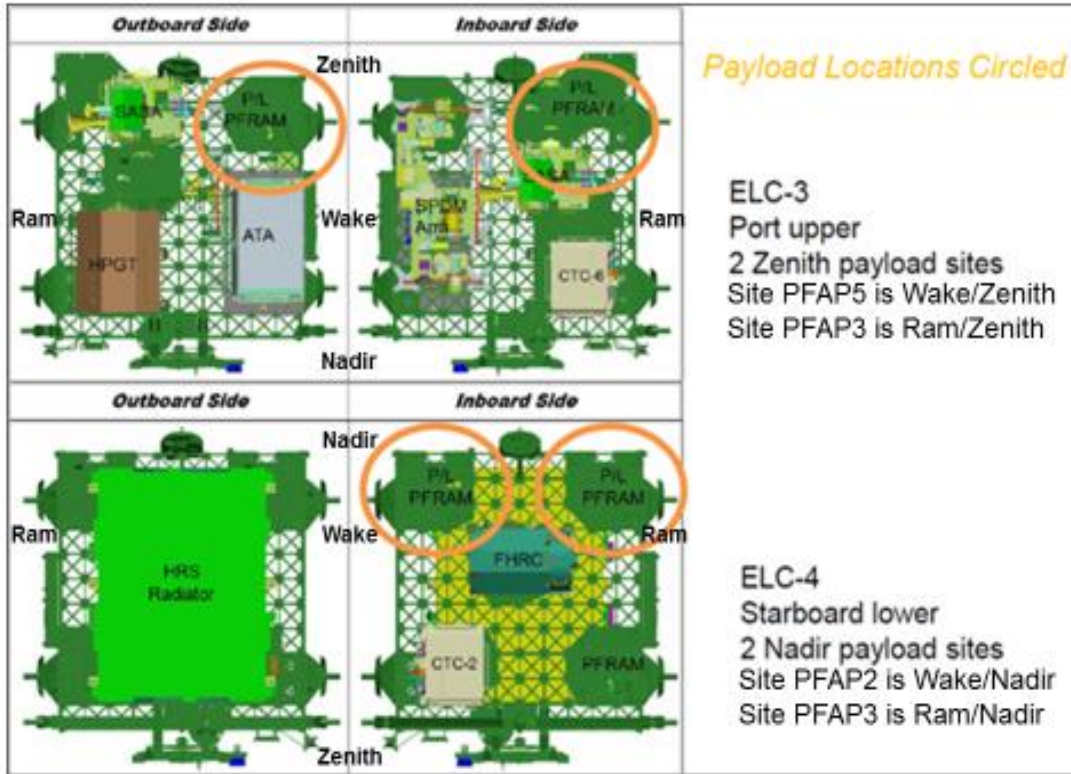


FIGURE 4.1.2-2 ELC LOCATION ON ISS

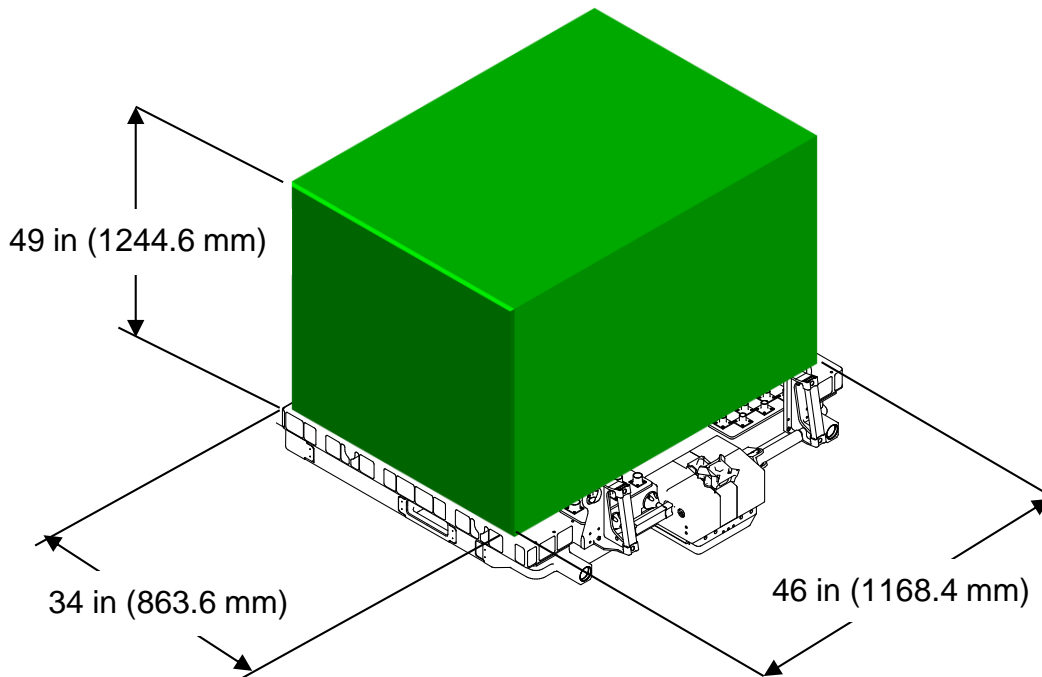


FIGURE 4.1.2-3 EXPA PAYLOAD ENVELOPE

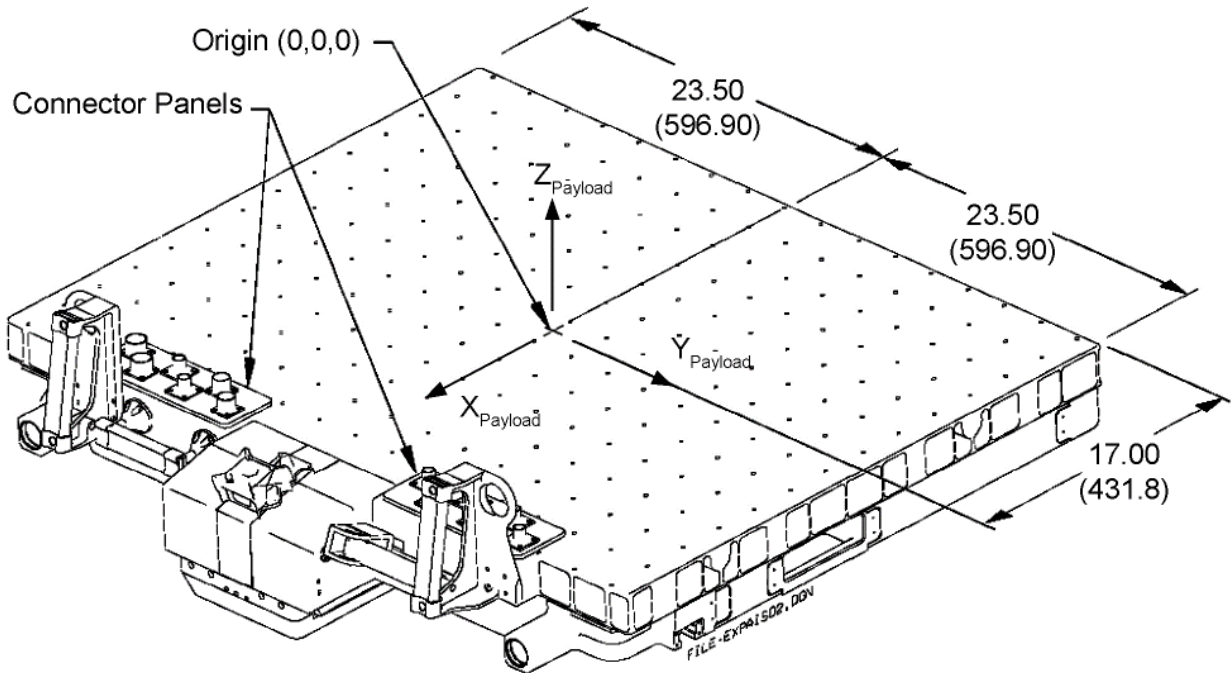


FIGURE 4.1.2-4 GENERIC EXPA PAYLOAD COORDINATE SYSTEM

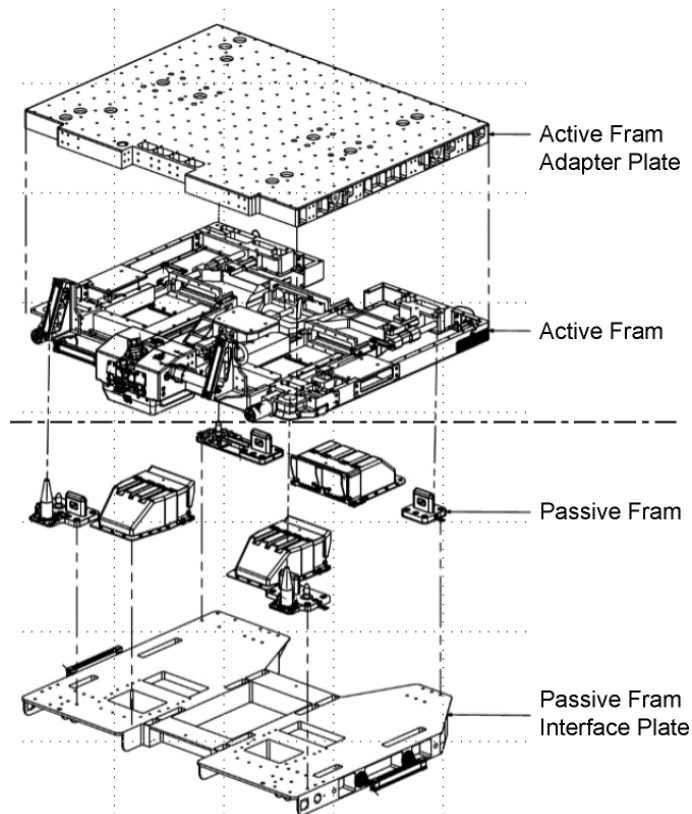


FIGURE 4.1.2-5 AFRAM AND PFRAM EXPENDED VIEW (NOTE: AFRAM ADAPTER PLATE AND THE AFRAM IS CONSIDERED A SINGLE UNIT)



The Payload Mass capabilities for each ExPA, excluding support equipment (e.g., ExPA/AFRAM, FRGF, electrical connector, handrails, etc.) are specified in Table 4.1.2-1, Allowable Mass and C.G. Location of ExPA Payloads, based upon the payload C.G. location.

**TABLE 4.1.2-1 ALLOWABLE MASS AND C.G. LOCATION OF EXPA PAYLOADS**

Payload Mass lb [kg]	Maximum Deviation From Geometric Center In The $X_{\text{Payload}}$ , $Y_{\text{Payload}}$ Plane in [mm]	Maximum Height ( $Z_{\text{Payload}}$ ) of Generic CEP CG Above The FRAM Plate Mounting Plane in [mm]
401 – 500 [181.9 – 226.8]	7.5, 7.5 [190, 190]	19.5 [495]
301 – 400 [136.5 – 181.4]	9, 10 [229, 254]	24.0 [610]
201 – 300 [91.2 – 136.1]	10.5, 12 [267, 305]	28.0 [711]
<200 [<90.7]	12, 14 [305, 356]	30.0 [762]

### 4.1.3 ROBOTICS

Please review the robotics section contained in Section 3.0, prior to reviewing the specific robotic requirements/accommodations outlined below.

The SSRMS is used in conjunction with the SPDM, or Dextre, to remove a payload from the docked visiting vehicle, transfer the payload to the ELC location, and perform the installation of the payload onto the appropriate external payload location.

Dextre can interface directly with an ExPA, by using the attachments contained on the ExPA. This interface should not impact payloads, if the PD stays within the defined mass and volume allocated on the ExPA. The primary purpose of the Dextre is to perform tasks that require fine, minute control. In the past, such tasks have been performed by EVA crewmembers, so being able to perform these tasks with Dextre removes the risk to EVA crewmembers.

A SpaceX Dragon carrying an ExPA payload in the Dragon Trunk will be attached at the designated ISS node location. The SSRMS will pick up the Dextre robot, and bring it to near the Dragon. Dextre will reach into the Dragon trunk and an OTCM will engage the fixture on the ExPA (active FRAM portion) of the integrated attached payload. The payload will be released from the Dragon by OTCM driving a bolt with the torque wrench to release the connector and the four clamps, and then Dextre will remove the payload. After bringing the external payload to the ELC site, it will be installed onto the appropriate external location. After release of the Dragon connector, the payload will have no survival heater power and must be able to survive a minimum of 6 hours without power.

#### 4.1.4 THERMAL

You should note that the ELC payload sites do not provide active thermal control interfaces. Thus, your external attached payload will need to be compliant with the following key thermal parameters for interface with the ISS, you may refer to SSP 57003-ELC<sup>44</sup> and SSP 57003.<sup>43</sup> The external attached payload will need to be designed to rely solely on payload-based thermal control mechanisms, such as optical coating selection, insulating blankets, heater circuits, heat-pipe radiators, etc.

##### Unpowered Survival

All external payloads shall be able to survive 6 hours without power in the translation configuration and during on-orbit power-downs (planned loss of power) (SSP 57003-ELC, Revision D, Paragraph 3.4.4.1.1).<sup>44</sup>

##### External Payload Temperatures

The AFRAM and PFRAM thermal extremes shall have minimum and maximum temperature limits of  $-93\text{ }^{\circ}\text{C}$  ( $-135\text{ }^{\circ}\text{F}$ ) to  $127\text{ }^{\circ}\text{C}$  ( $260\text{ }^{\circ}\text{F}$ ) (SSP 57003-ELC, Revision D, Paragraph 3.4.4.3.1).<sup>44</sup>

##### External Payload Temperature Constraints

The PD should plan for thermally conditioning the integrated external payload such that the maximum temperature differential between the AFRAM and PFRAM shall be no more than  $102\text{ }^{\circ}\text{C}$  ( $215\text{ }^{\circ}\text{F}$ ) (SSP 57003-ELC, Revision D, Paragraph 3.4.4.3.1).<sup>44</sup>

##### Thermal Conduction

The external payload must not use the ELC as a heat sink and must not employ thermal control methods that reject heat to neighboring payloads (SSP 57003-ELC, Revision D, Paragraph 3.4.4.3).<sup>44</sup>

##### Thermal Radiation

All external payload heat rejection requirements shall be met through radiation to the environment with all thermal radiators being confined to the FRAM payload envelope dimensions previously defined (SSP 57003-ELC, Revision D, Paragraph 3.4.4.3).<sup>44</sup>

##### Payload Radiator View Factor

External payload active radiation surfaces (surfaces designed to reject heat generated by the payload) shall be oriented so that they have a cumulative view factor no greater than 0.1 to any ISS radiators or any surface of the generic envelope, as defined in Paragraph 4.1, placed on any other S3 or P3 attachment site (SSP 57003-ELC, Revision D, Paragraph 3.4.4.2).<sup>44</sup>

##### Payload Surface Specular Reflectivity

External payload surfaces with a view to any ISS or other external payload surface shall have a specular reflectivity of 10% or less (SSP 57003, Revision H, Paragraph 3.4.3).<sup>41</sup>

### Pressure

The on-orbit minimum pressure environment that the integrated external payload will experience is  $1.0 \times 10^{-7}$  Torr ( $1.333 \times 10^{-5}$  Pa) (SSP 57003-ELC, Revision D, Paragraph 3.5.2.2.1).<sup>44</sup>

### Space Sink Temperature

The integrated external payload will be exposed to, and must be compatible with, a space sink temperature of 3 K (5.4 R).

### Thermal Models

Key thermal considerations that must be addressed by the external PD are the development and delivery of a thermal model in required format and generation of thermal analyses to demonstrate that the payload will remain safe during Launch-To-Activation (LTA), as well as applicable on-orbit stowage sites on the ISS. These models will be provided to support required thermal assessment by the launch vehicle integrator and the ISS vehicle integrator.

The external PD will be required to develop and deliver a thermal model compatible with Thermal Desktop<sup>®</sup> and TRASYS/SINDA. The model is expected to be comprised of no more than 500 geometric and 500 mathematical nodes that represent all geometric and material properties required for determining critical hardware temperatures. These models will be utilized by the PD to assess the external payload in its on-orbit configuration, including the time periods while stowed in the launch vehicle and on the ISS ELC. These models will be provided to the ISS Program in order to support required thermal assessments by the launch vehicle integrator and the ISS vehicle integrator.

### Thermal Analysis

The external attached payload must remain safe during the LTA phase while stowed in the launch vehicle, as well as, during the subsequent phase while it is stowed on an ISS ELC when it is exposed to a space sink temperature of 3 K, the thermal environment parameters defined in Table 4.1.4-1, Thermal Environment Parameters, the ISS flight attitudes and solar beta angle ranges defined in Table 4.1.4-2, ISS Flight Attitudes, (similar attitude requirements will be defined for the applicable launch vehicle) and the thermal interactions with all other on-orbit hardware. Verification of safe operation will require PD generated thermal analysis using ISS Program-provided launch vehicle and ISS thermal models integrated with a PD-developed thermal model of the proposed payload.

**TABLE 4.1.4-1 THERMAL ENVIRONMENT PARAMETERS**

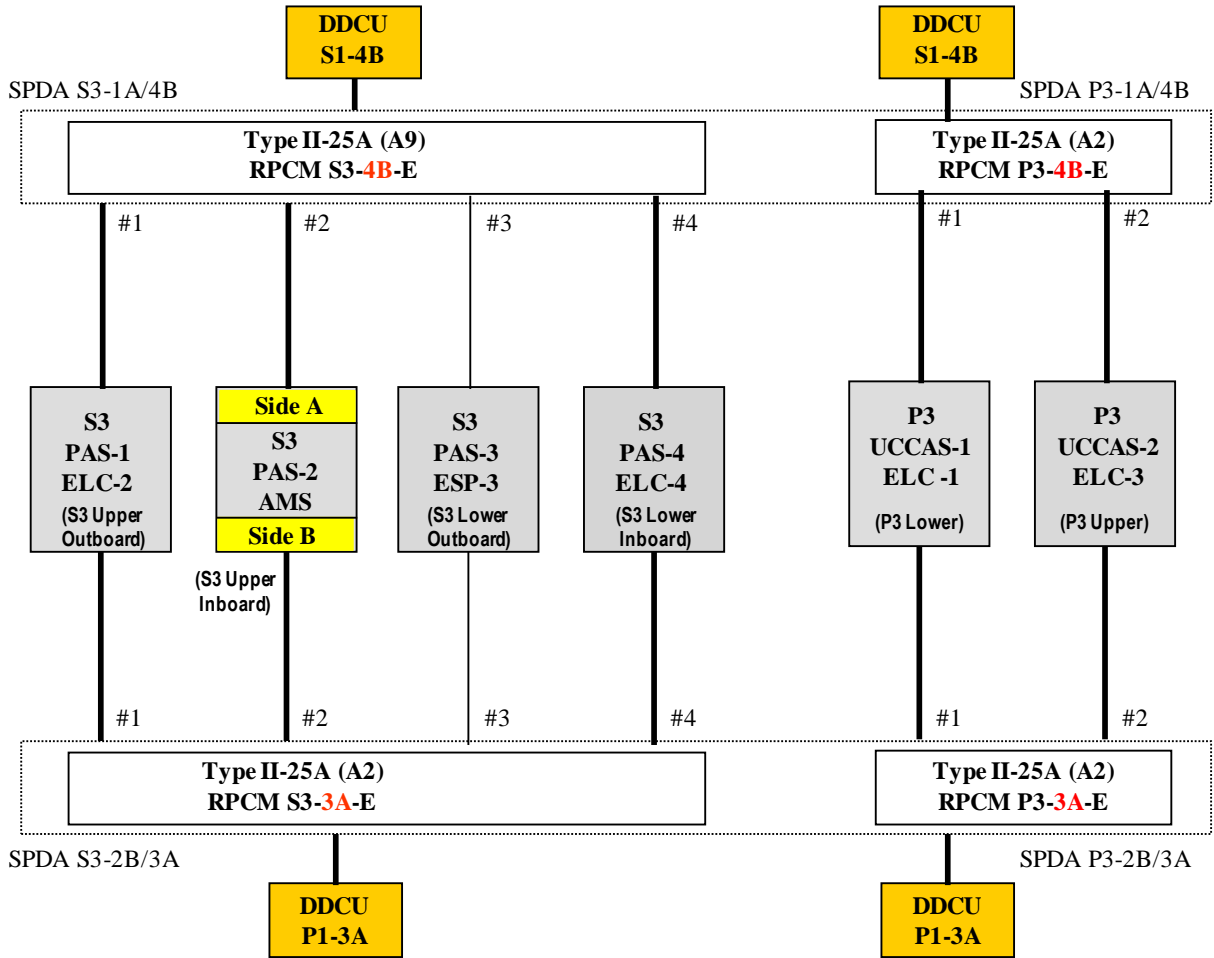
Case	Solar Constant (W/m <sup>2</sup> )	Earth Albedo	Earth Outgoing Long-Wave Radiation (OLR) (W/m <sup>2</sup> )	Altitude (km)
Cold	1321	0.2	206	500
Hot	1423	0.4	286	278

**TABLE 4.1.4-2 ISS FLIGHT ATTITUDES**

ISS Attitude Name	Attitude Reference Frame	Solar Beta Range ( $\beta$ )	Yaw	Pitch	Roll	Time in Attitude
+XVV +Z Nadir	LVLH	$-75^\circ \leq \beta \leq +75^\circ$	$-15^\circ$ to $+15^\circ$	$-20^\circ$ to $+15^\circ$	$-15^\circ$ to $+15^\circ$	No Limit
-XVV +Z Nadir	LVLH	$-75^\circ \leq \beta \leq +75^\circ$	$+165^\circ$ to $+195^\circ$	$-20^\circ$ to $+15^\circ$	$-15^\circ$ to $+15^\circ$	No Limit
+YVV +Z Nadir	LVLH	$-75^\circ \leq \beta \leq +10^\circ$	$-110^\circ$ to $-80^\circ$	$-20^\circ$ to $+15^\circ$	$-15^\circ$ to $+15^\circ$	No Limit
-YVV +Z Nadir	LVLH	$-10^\circ \leq \beta \leq +75^\circ$	$+75^\circ$ to $+105^\circ$	$-20^\circ$ to $+15^\circ$	$-15^\circ$ to $+15^\circ$	No Limit
+ZVV -X Nadir	LVLH	$-75^\circ \leq \beta \leq +75^\circ$	$-15^\circ$ to $+15^\circ$	$+75^\circ$ to $+105^\circ$	$-15^\circ$ to $+15^\circ$	3 Hours
-ZVV -X Nadir	LVLH	$-75^\circ \leq \beta \leq +75^\circ$	$+165^\circ$ to $+195^\circ$	$+75^\circ$ to $+105^\circ$	$-15^\circ$ to $+15^\circ$	3 Hours

#### 4.1.5 POWER

The ISS provides two 3-kW feeds at each S3/P3 attach site, which provide power to the ELC interfaces. Each site must use one of the feeds as main (primary) power for operational use, and the other as auxiliary (keep-alive) power. External payloads may use both power feeds simultaneously provided the power bus isolation requirements are met. External payloads delivered to the ISS should nominally expect to be unpowered during transfer to the ISS for a minimum of 6 hours, as described in Paragraph 4.1.3, Robotics. Payloads that cannot withstand a lack of power for this duration must pre-arrange with the ISS for special accommodations or provide their own power source. Figure 4.1.5-1, ITA ISS Interfaces, illustrates the interfaces for the ITA sites, available for external payloads.

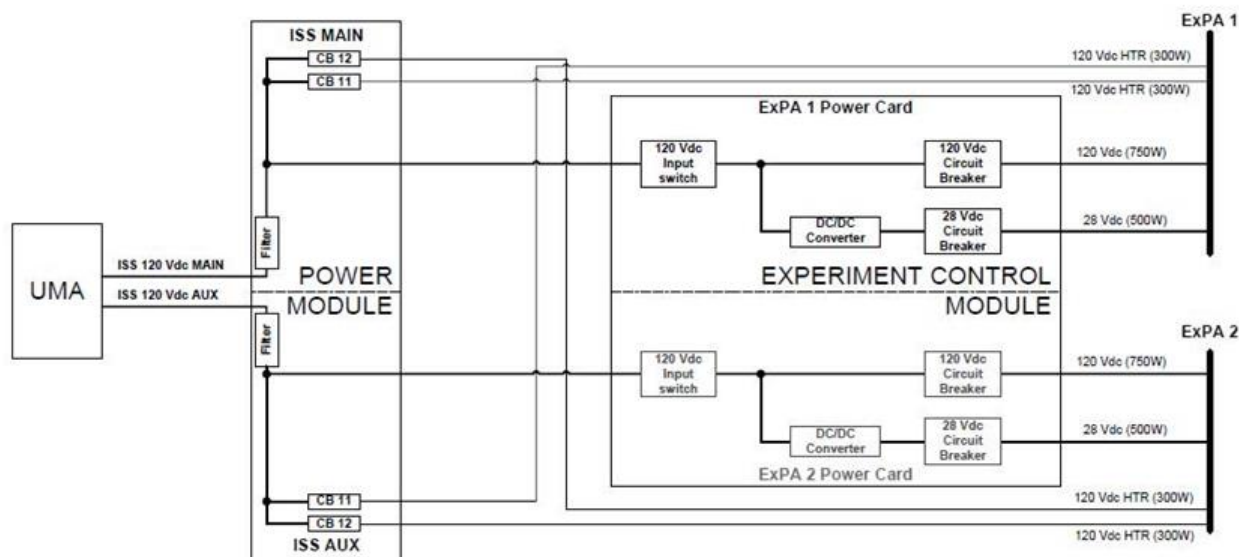


Note: The items that appear with a red marking are not to be utilized by external payloads.

**FIGURE 4.1.5-1 ISS ITA INTERFACES**

Each ExPA payload will be provided with two +120-Vdc heater power buses, one +120-Vdc operational power bus and one operational +28-Vdc power bus.

The ExPA also contains the power and data connectors, which connect with the corresponding connectors already mounted on the ELC. The PD simply needs to provide the cabling, etc., required to mate with the ExPA connector. Figure 4.1.5-2, ISS to ExPA Power Block Diagram, provides an electrical block diagram that represents accommodations between the ISS and ExPA.



**FIGURE 4.1.5-2 ISS TO EXPA POWER BLOCK DIAGRAM**

#### +120 Vdc Heater Power

There are two +120-Vdc heater power services provided to each ExPA payload and these are only to be used for heaters systems. One of these services is considered to be primary and the other service is considered to be auxiliary and intended to be utilized as a backup heater power source in case of loss of primary 120-Vdc heater power. External payloads may use both power feeds at the same time for heaters systems. The heater power service provides the maximum 300-W power consumption. For more detailed power characteristics, such as ripple voltage and noise, non-normal voltage transients, surge current, load impedance, reverse current and wire de-rating, you may refer to SSP 57003-ELC.<sup>44</sup>

Note: External payload heaters systems which use bimetallic thermostats and resistive heaters to control temperatures do not require power characteristics verification as defined by Paragraph 3.2.3.2.1 of SSP 57003-ELC.<sup>44</sup> Refer to approved EPS-TIA-076 for details.

#### +120 Vdc Operational Power

There is a single +120-Vdc operational power service provided to each ExPA payload with the maximum 750-W power consumption. The steady state voltage varies from +106.5 Vdc to +126.5 Vdc. For more detailed power characteristics, such as ripple voltage and noise, non-normal voltage transients, surge current, load impedance, large signal stability, reverse current and wire de-rating, you may refer to SSP 57003-ELC.<sup>44</sup>

#### +28 Vdc Operational Power

There is a single +28-Vdc operational power service provided to each ExPA payload with the maximum 500-W power consumption. The steady-state voltage of this power bus varies from +27 Vdc to +30.8 Vdc. For more detailed power characteristics, such as turn-on voltage profile, voltage ripple, normal and abnormal transient voltages,

transient current, current rise time, current rate of change, reverse electro-magnetic force limits and input impedance, ground isolation and compatibility with soft start, you may refer to SSP 57003-ELC.<sup>44</sup>

ExPA Power Connectors

There are four circular connectors provided to the payload for power interfaces. These connectors are described in Table 4.1.5-1, ExPA Power Connectors, by connector designator, total number of contacts, contact gauge, function, and mating connector part number. Note that J4 is not connected on-orbit and request for use of this connector for launch must be coordinated with NASA Visiting Vehicle Office at JSC. Refer to SSP 57003-ELC<sup>44</sup> for pin assignments on each of the connectors.

**TABLE 4.1.5-1 EXPA POWER CONNECTORS**

Connector Designator	Total # of Contacts	Contact Gauge	Function	Mating Connector Part Number (P/N) (or equivalent)
J1	4	12	+120-Vdc Operational Power	NATC06G15N4PN
J3	6	20	+120-Vdc Primary/Auxiliary Heater Power	NATC06G11N98PN
J4	9	12	+28-Vdc Heater Power (launch)	NATC06G19N96PN
J5	4	12	+28-Vdc Operational Power	NATC06G15N4PA

**4.1.6 COMMAND AND DATA HANDLING (C&DH)**

There are various data interfaces available for FRAM-based cargo utilizing an ExPA. Figure 4.1.6-1, ISS to ExPA C&DH Block Diagram, illustrates the ExPA experiment-to-ELC C&DH interfaces. For each ExPA payload, there are various data interfaces, namely, 1553 data bus, Ethernet, analog and digital (discrete) signals, and wireless MRDL for the PD to utilize. The specifics of these interfaces are defined in the following paragraphs. Note that there are no audio or video interfaces available for the ELC/ExPA experiment.

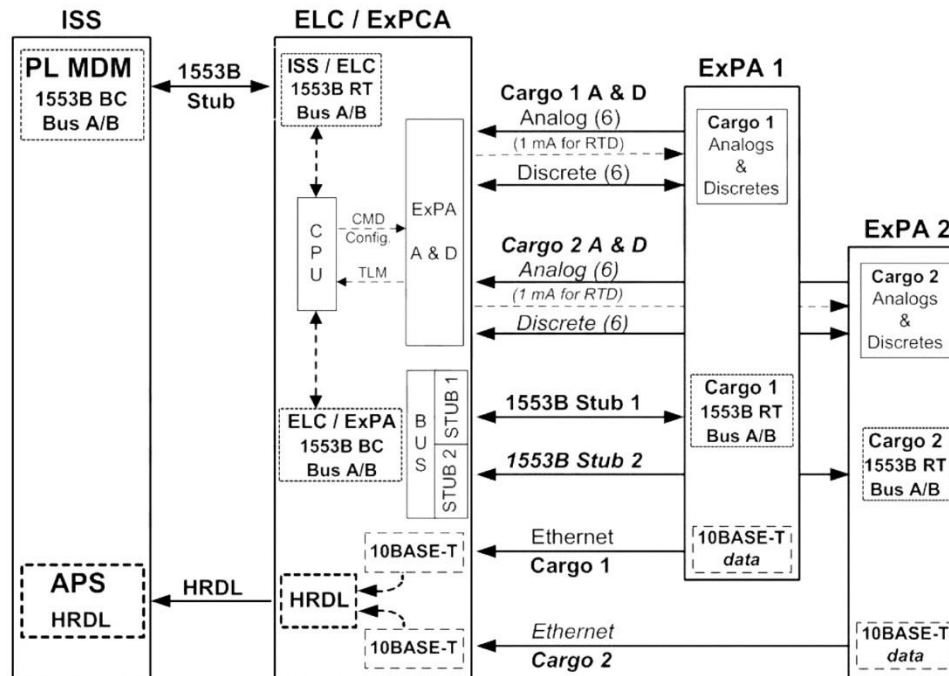


FIGURE 4.1.6-1 ISS TO EXPA C&DH BLOCK DIAGRAM

### Low Rate Data Link (LRDL)

The ExPRESS Payload Control Assembly (ExPCA) provides a MIL-STD-1553B<sup>14</sup> serial data bus for LRDL (20 kbps typical telemetry throughput) for up to two ExPAs. This serial data bus will be used to exchange commands, broadcast time, request responses, BAD, perform file transfers, and transmit payload health and status data, payload requests, and payload science data (when selected) for downlink. The ExPCA will operate as the 1553 Bus Controller (BC) and the payload will operate as the 1553 RT. The ExPA payload shall develop standard messages for the ELC ExPA/FRAM-based MIL-STD-1553B<sup>14</sup> bus in accordance with SSP 52050, Rev. K, International Standard Payload Rack to International Space Station, Software Interface Control Document Part 1, Paragraph 3.2.3.3.<sup>42</sup> Refer to SSP 57003-ELC<sup>44</sup> for detailed characteristics such as RT address and parity inputs. Examples of BAD are available in Paragraph 5.2, ISS Operations of this document.

### Discrete

There are six discrete (interfaces) channels provided via the ELC ExPCA. The discrete channels are bi-directional and can be individually programmed, via 1553B commanding, to be input (to the ExPCA) or output (from the ExPCA) as single-ended signals. The sampling rate to/from ExPCA is 1 Hz. Discrete input interfaces operate as steady state while discrete output interfaces can operate as either steady state or pulsed.

Discrete steady-state outputs and inputs operate using +5 and +28 logic-level signals. Discrete pulsed outputs operate using +5 and +28 V from the ExPCA. A switch closure detection mode is also available via an ExPA provided excitation voltage of +2.4 Vdc to



+6 Vdc at a maximum current of 40 mA  $\pm$ 5 mA. Refer to SSP 57003-ELC<sup>44</sup> for detailed discrete interface characteristics.

### Analog

Each payload will have six analog interfaces to provide temperature or preconditioned signal inputs to the ExPCA. The preconditioned signal inputs are configurable to either a current, or voltage, mode with an opportunity for the payload to multiplex signals in voltage mode. For temperature monitoring, the ExPCA will provide a 1-mA constant current to drive and monitor 1 K $\Omega$ , 2-wire Resistance Temperature Detectors. Each analog channel (interface) will be sampled at a rate of 10 Hz and then combined into a composite output will be transmitted to the ISS at a 1-Hz rate. Refer to Paragraph 3.3.3.3 of SSP 57003-ELC<sup>44</sup> for additional information regarding the analog interface capabilities, signal characteristics and the variable gain and offset programmability provided by the ExPCA. On-orbit changes to the configuration of the analog channels are possible through a ground-commanded upload of the ExPCA electrically erasable programmable read only memory.

### Ethernet

Ethernet provides a one-way 10 Base T downlink for science data. The data stream is converted to HRDL by the ExPCA and sent to the ISS data system. Each ExPA can send data at up to 10 Mbps. The Ethernet frame content conforms to the Payload Ethernet Hub Gateway (PEHG) HRDL gateway Layer 2 format per SSP 52050 Rev. K, Paragraph 3.3.5.1.<sup>42</sup>

### ExPA C&DH Connectors

There are six circular connectors provided to the payload for communications interfaces. These are described in Table 4.1.6-1, ExPA C&DH Connectors, by connector designator, total number of contacts, contact gauge, function, and mating connector part number. Note that no signals are available through the J8 connector on the FRAMs on the ELCs. Refer to SSP 57003-ELC<sup>44</sup> document for pin assignments on each of the connectors.

**TABLE 4.1.6-1 EXPA C&DH CONNECTORS**

Connector Designator	Total # of Contacts	Contact Gauge	Function	Mating Connector P/N (or equivalent)
J7	22	22	1553 Bus 1 and Ethernet	NATC06G13N35SA
J8	22	-	1553 Bus 2	-
J9	13	22	Analog Monitor Channel 1 – 3	NATC06G11N35SA
J10	13	22	Analog Monitor Channel 4 – 6	NATC06G11N35SB
J11	13	22	Discrete Monitor Channel 1 - 3	NATC06G11N35SC
J12	13	22	Discrete Monitor Channel 4 – 6	NATC06G11N35SN

**4.1.7 WIRELESS CAPABILITY**

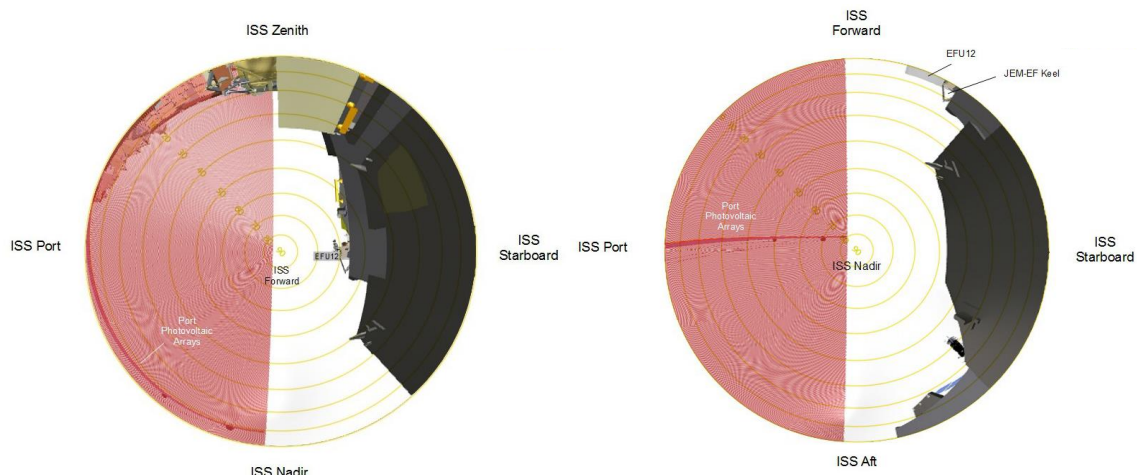
Refer to Paragraph 3.1.2, Wireless Capabilities.

**4.1.8 FIELD OF VIEW (FOV)**

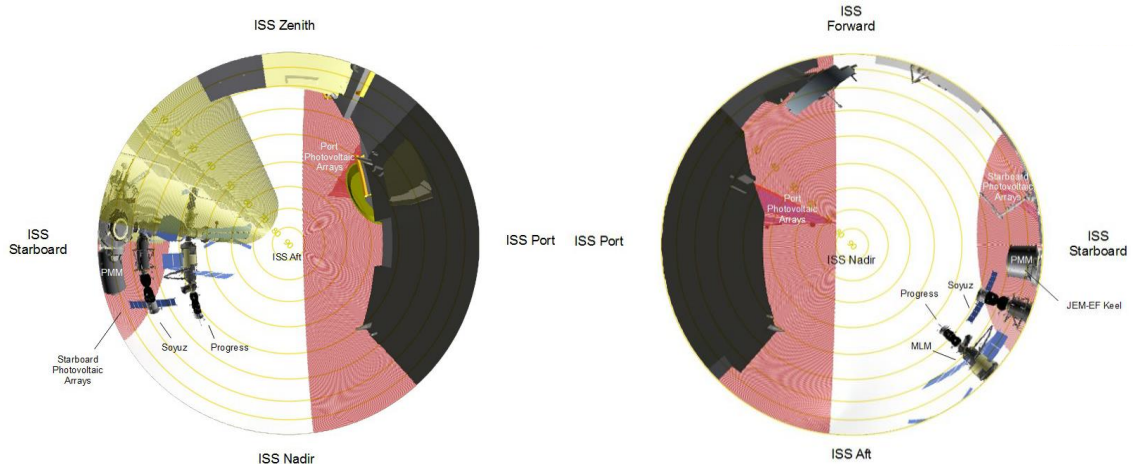
The following provides the proposer a series of fish-eye images of the FOV from those ELC ExPA/FRAM locations available to hosted NASA external payloads. The viewpoint location for these images (Figures 4.1.8-1 through 4.1.8-8) was defined with respect to the ExPA origin and is 22 inches in toward the ExPA center and 16 inches up. These images were generated by the Manipulator Analysis Graphics and Interactive Kinematics (MAGIK) Team software tools, at JSC ISS Program. The solid objects in the FOV remain there at all times while the pink shaded areas in the FOV represent the areas swept by the ISS solar (photovoltaic) arrays as they track the sun. A summary of these fish-eye FOV images is provided in Table 4.1.8-1, Index of ELC Fish-Eye FOV Images.

**TABLE 4.1.8-1 INDEX OF ELC FISH-EYE FOV IMAGES**

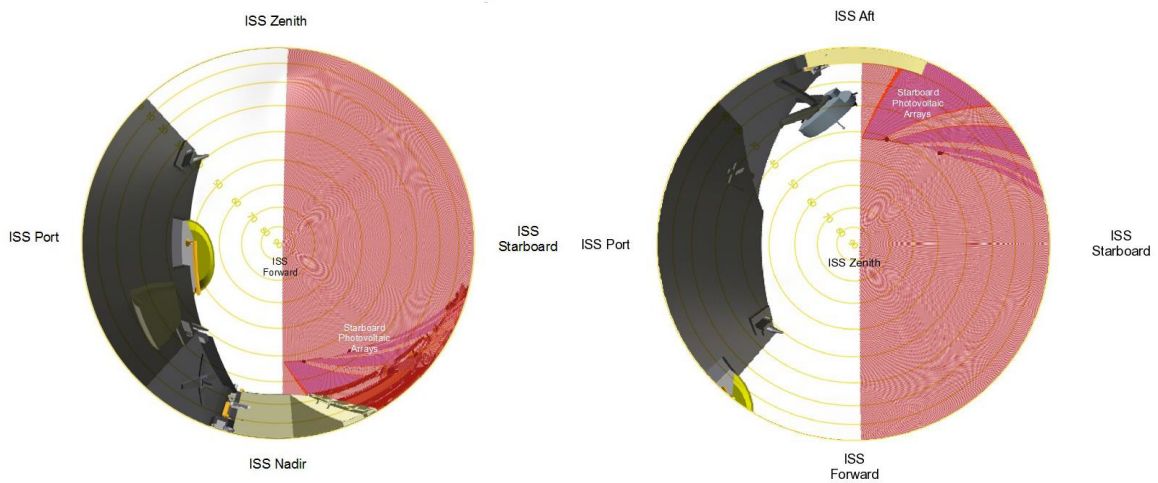
Carrier	Location	Site	Optimum Viewing Directions	ISS Aft FOV	ISS Forward FOV	ISS Nadir FOV	ISS Zenith FOV
ELC-1	P3 Lower	ExPA 3	Ram/Nadir	-	✓	✓	-
		ExPA 8	Wake/Nadir	✓	-	✓	-
ELC-2	S3 Upper	ExPA 7	Ram/Zenith	-	✓	-	✓
		ExPA 3	Ram/Zenith	-	✓	-	✓
ELC-3	P3 Upper	ExPA 5	Wake/Zenith	✓	-	-	✓
		ExPA 3	Ram/Zenith	-	✓	-	✓
ELC-4	S3 Lower	ExPA 3	Ram/Nadir	-	✓	✓	-
		ExPA 2	Wake/Nadir	✓	-	✓	-



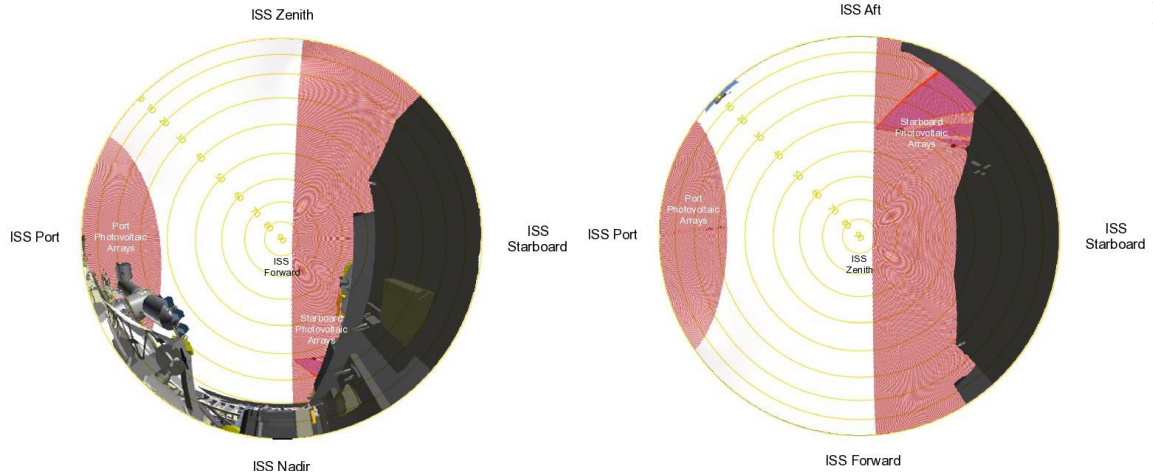
**FIGURE 4.1.8-1 ELC-1 OUTBOARD EXPA PAYLOAD ACCOMMODATION FORWARD (RAM) AND NADIR**



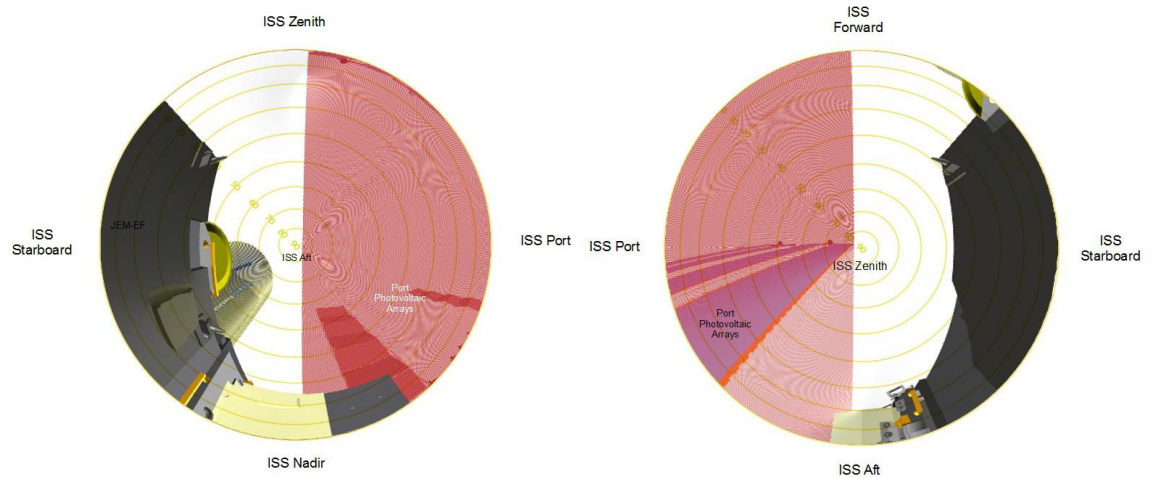
**FIGURE 4.1.8-2 ELC-1 INBOARD EXPA PAYLOAD ACCOMMODATION AFT (WAKE) AND NADIR**



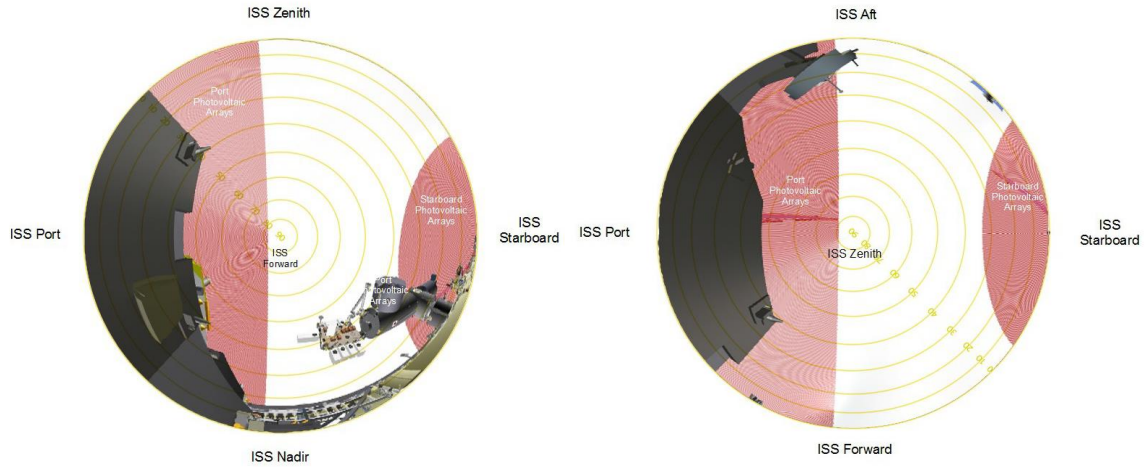
**FIGURE 4.1.8-3 ELC-2 OUTBOARD EXPA PAYLOAD ACCOMMODATION FORWARD (RAM) AND ZENITH**



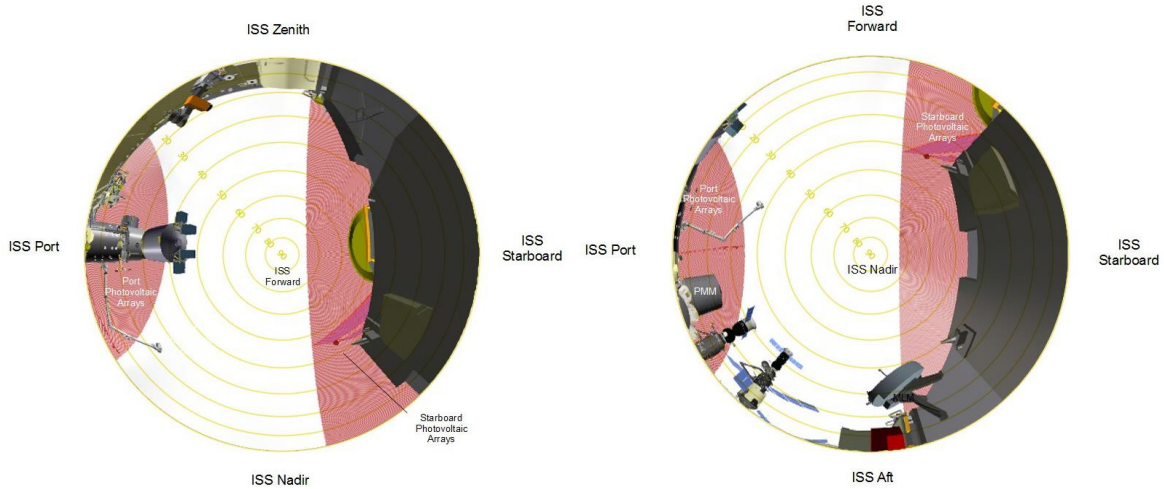
**FIGURE 4.1.8-4 ELC-2 INBOARD EXPA PAYLOAD ACCOMMODATION FORWARD (RAM) AND ZENITH**



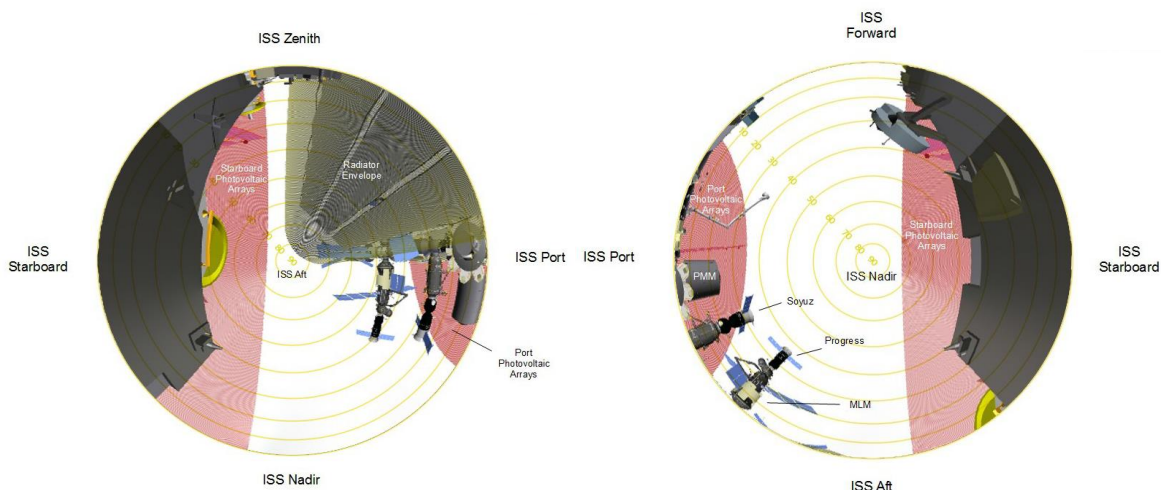
**FIGURE 4.1.8-5 ELC-3 OUTBOARD EXPA PAYLOAD ACCOMMODATION AFT (WAKE) AND ZENITH**



**FIGURE 4.1.8-6 ELC-3 INBOARD EXPA PAYLOAD ACCOMMODATION FORWARD (RAM) AND ZENITH FOVS**



**FIGURE 4.1.8-7 ELC-4 INBOARD EXPA PAYLOAD ACCOMMODATION FORWARD (RAM) AND NADIR FOVS**



**FIGURE 4.1.8-8 ELC-4 INBOARD EXPA PAYLOAD ACCOMMODATION AFT (WAKE) AND NADIR FOVS**

#### **4.1.9 ELECTROMAGNETIC COMPATIBILITY/ELECTROMAGNETIC INTERFERENCE (EMC/EMI)**

EMC/EMI requirements are contained in SSP 30237, Space Station Electromagnetic Emission and Susceptibility Requirements,<sup>26</sup> electrical grounding in SSP 30240, Space Station Grounding Requirements,<sup>27</sup> cable and wired design in SSP 30242, Space Station Cable/Wire Design and Control Requirements for Electromagnetic Compatibility,<sup>28</sup> corona and electrostatic discharge (ESD) immunity in SSP 30243, Space Station Requirements for Electromagnetic Compatibility,<sup>29</sup> and electrical bonding in SSP 30245, Space Station Electrical Bonding Requirements.<sup>30</sup> The PD should, at a minimum, review the following paragraphs:

SSP 30237:

CONDUCTED EMISSIONS: Paragraph 3.2.1 and all subordinate paragraphs

CONDUCTED SUSCEPTIBILITY: Paragraph 3.2.2 and all subordinate paragraphs

RADIATED EMISSIONS: Paragraph 3.2.3 and all subordinate paragraphs

RADIATED SUSCEPTIBILITY: Paragraph 3.2.4 and all subordinate paragraphs

SSP 30240:

GROUNDING: Paragraph 3.2 and all subordinate paragraphs

CABLE/WIRE DESIGN for EMC: Paragraph 3.1

ESD: Paragraph 3.2.9

CORONA: Paragraph 3.2.13

ELECTRICAL BONDING: Paragraph 3.1

Alternately, Attached Payloads may choose to accept a minimal increase of EMI risk with a somewhat less stringent electrical field radiated susceptibility (RS03) requirement on equipment considered non-safety critical to the vehicle and crew as described in SSP 57003-ELC, Paragraph 3.2.2.4.4.<sup>44</sup>

Attached Payload circuits that exhibit a failure or anomalous behavior due to EMI and can cause or propagate a hazard due to such behavior is deemed safety-critical and shall meet the margins defined in SSP 30243, Paragraph 3.2.3.<sup>29</sup>

Questions concerning requirements applicability or purpose can be addressed to the ISS Electromagnetic Effects Panel co-chairs.

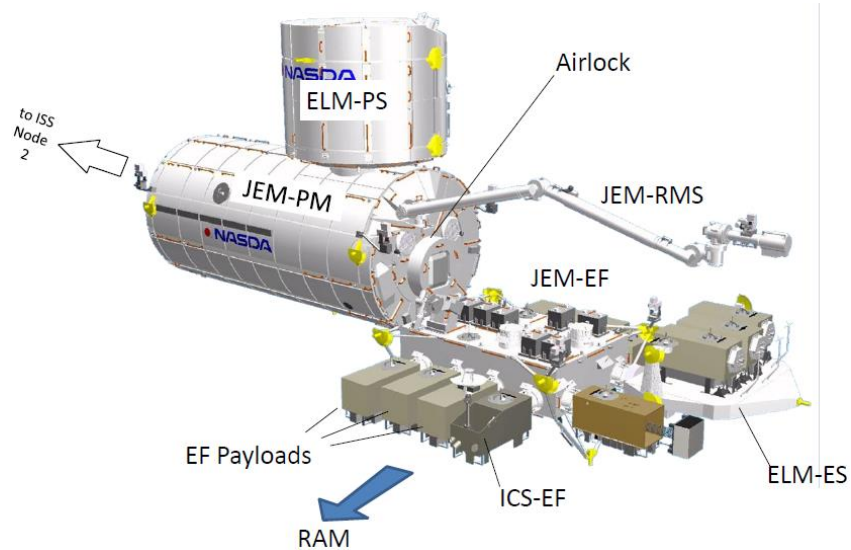
For more information concerning designing to meet EMC requirements, see NASA Reference Publication 1368, Marshall Space Flight Center Electromagnetic Compatibility Design and Interference Control (MEDIC) Handbook, available on the NASA Technical Reports Server at <http://ntrs.nasa.gov>.<sup>15</sup>

Additionally, ISS Program Management Directive, ISSP-MD-113, ISS Intentional Radiating and Receiving Systems Certification Policy for US-Funded Equipment/Systems, applies to all U.S.-funded intentional transmitting and receiving systems for operation on the ISS. This policy provides the authority and requirement to conduct technical reviews in ensuring RF compatibility of the proposed RF system/usage with existing ISS RF operation.

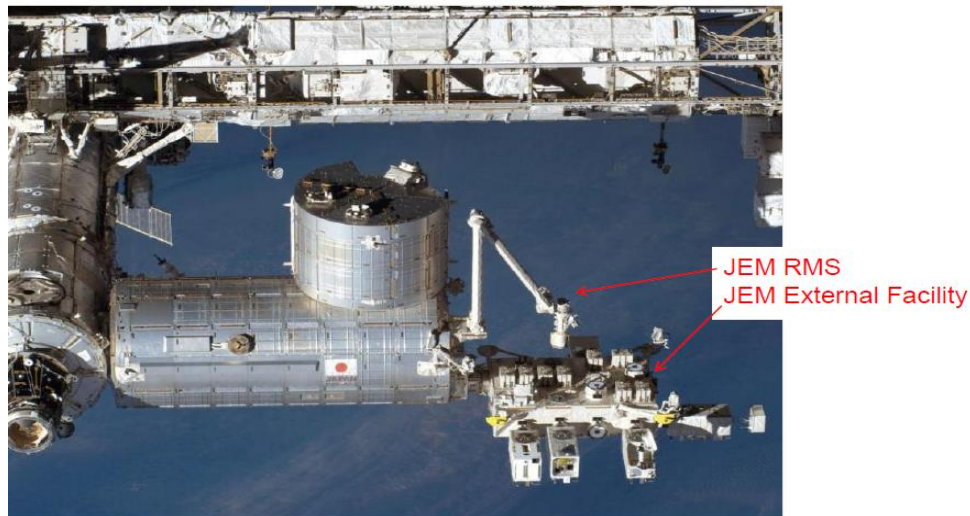
Regarding International Partner (IP)-managed RF payloads for the ISS, the process for coordination of frequency selection and compatibility assurance will be worked through the JSC Spectrum Manager (designated as the ISS Spectrum Manager) as documented in SSP 50423, ISS Radio Frequency Coordination Manual.<sup>39</sup> Additionally, regulatory filing and approval for space operation of an IP-managed RF payload is the responsibility of the IP, consistent with the applicable domestic regulation and process of the IP. The International filing documentation, at the minimum of Advanced Publication Information (API) stage, is to be provided to the ISS Spectrum Manager for final validation of ISS onboard compatibility certification. Upon this validation, the payload will be issued an ISS RF Authorization document for Program ICD and IRD requirements closure.

#### **4.2 JAPANESE EXPERIMENT MODULE-EXTERNAL FACILITY (JEM-EF)**

While there are numerous similarities between the ELC and Columbus-EPF capabilities, the JEM-EF stands apart. The JEM-EF offers active cooling, for example, and its physical accommodations and layout are strikingly different from the other two ISS external payload sites. The JEM-EF, in its entirety, is 6 m x 5 m x 4 m (20 ft x 16.7 ft x 13.3 ft) and weighs approximately 4000 kg (8890 lb), and is represented in Figures 4.2-1, Illustrated JEM-EF Overview and 4.2-2, Image of JEM-EF from Space. The JEM-EF can accommodate 11 different payloads, five of which are NASA allocated. The JEM consists of the Pressurized Module, the EF, the Experiment Logistics Module (ELM), and the JEM Remote Manipulator System (RMS). This Section of the Guide provides an overview suitable for ISS proposers.



**FIGURE 4.2-1 ILLUSTRATED JEM-EF OVERVIEW**



**FIGURE 4.2-2 IMAGE OF JEM-EF FROM SPACE**

**4.2.1 PHYSICAL ACCOMMODATIONS**

For interfacing with the JEM-EF, the locations are referred to as a standard site and a large site. The standard site has a 550-kg (1,150-lb) mass limit, and the large site has a 2,250-kg (5,500-lb) mass limit. However, these mass limits must include the Payload Interface Unit (PIU), EVA supporting hardware, Grapple Fixture (GF) supporting robotics interfaces, and other supporting hardware such as Multi-Layer Insulation (MLI), as required. It is expected that almost all proposers will utilize the standard site, primarily based on the availability of the standard sites versus the large site.

The JEM-EF provides 10 locations for experimental payloads, which are summarized below in Figure 4.2.1-1, Illustrated JEM-EF 10 Locations For Experimental Payloads. However, if you need detailed design-to references, please consult NASDA-ESPC-



2900A, JEM Payload Accommodations Handbook, Vol. 3 Exposed Facility Payload Standard Interface Control Document.<sup>17</sup>

A more detailed summary for each JEM-EF site is shown in Table 4.2.1-1, Detailed Summary for Each JEM-EF Site.

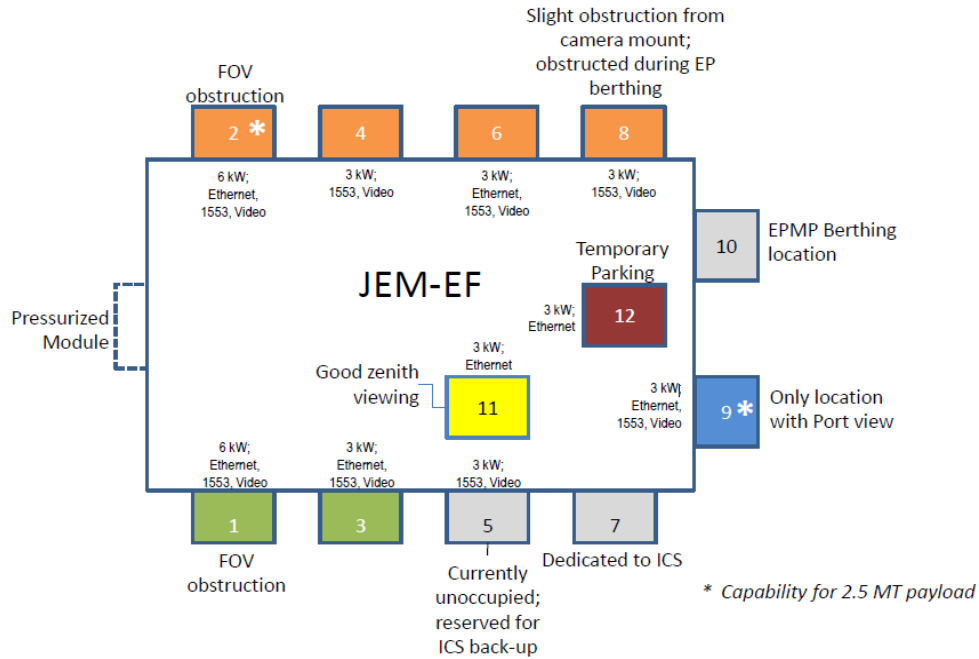


FIGURE 4.2.1-1 ILLUSTRATED JEM-EF 10 LOCATIONS FOR EXPERIMENTAL PAYLOADS

**TABLE 4.2.1-1 DETAILED SUMMARY FOR EACH JEM-EF SITE**

Location	Viewing	Payload Size	Description / Notes	Power	Data
1	Ram, Nadir, Zenith	500 kg	Ram field of View (FOV) obstruction by JEM module	6 kW	Ethernet, 1553, Video
3	Ram, Nadir, Zenith	500 kg	Clear view	3 kW	Ethernet, 1553, Video
5	Ram, Nadir, Zenith	500 kg	ICS System back-up site (negotiable?)	3 kW	1553, Video
7	Ram, Nadir, Zenith	500 kg	ICS-dedicated	-	-
9	Port, Zenith, Nadir	2.5 MT	Best volumetrically for large payloads (up to 2.5 MT), but not necessarily the best viewing	3 kW	Ethernet, 1553, Video
2	Wake, Nadir, Zenith	2.5 MT	Can hold large payloads, but has an FOV obstruction by JEM module	6 kW	Ethernet, 1553, Video
4	Wake, Nadir, Zenith	500 kg	Clear view	3 kW	1553, Video
6	Wake, Nadir, Zenith	500 kg	Clear view	3 kW	Ethernet, 1553, Video
8	Wake, Nadir, Zenith	500 kg	Obstruction during EP berthing, slight obstruction from camera mount	3 kW	1553, Video
10	Wake, Nadir, Zenith	500 kg	EPMP berthing site	-	-
11	Zenith only	500 kg	Good Zenith viewing	3 kW	Ethernet
12	Zenith only	500 kg	Temporary stowage location	3 kW	Ethernet

### Payload Interface Unit (PIU)

The PIU interfaces payloads to the JEM-EF site. All payload accommodations, including power, data, and coolant, are provided through the PIU connectors. Figures 4.2.1-2, JEM-EF Typical Configuration and 4.2.1-3, Payload Interface Unit, provide an illustration of these units. In addition, NASDA-ESPC-3122, Payload Interface Unit Product Specification,<sup>19</sup> contains more detailed design-to type information for the PD that may be used as additional references.

All JEM-EF payloads must utilize the PIU and the supporting structure for interfacing with the JEM-EF, as this unit serves as your primary interface to the ISS. The structure will be provided by the PD.

The PD should select one of the following PIU types, based on the proposed usage:

1. PIU-Type A: Equipped with fluid interface
2. PIU-Type B: NOT equipped with fluid interface

NASA payloads utilizing the JEM-EF will most likely require active cooling, as this is a major difference between JEM-EF and the other ISS external payload sites. Therefore, most proposers will use the Type A PIU, in all probability.

The PIU is the passive half of the Equipment Exchange Unit (EEU), and is installed on your payload. The PIU is the critical interface for all accommodations from the JEM-EF, and has the following functions:

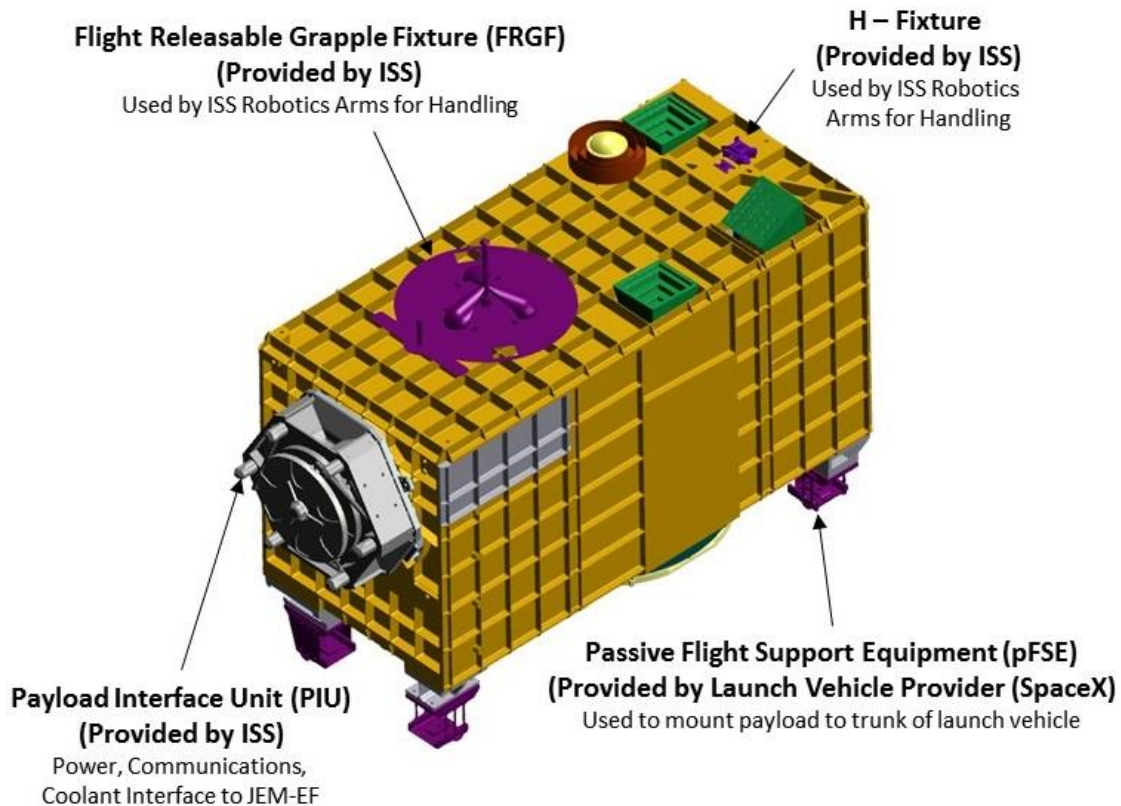
1. Kinetic energy absorption – the PIU damper cushions the “collision” between the payload and the JEM-EF EEU, during robotic installation.
2. On-orbit capturing and alignment – using the JEM arm, the PIU is captured and aligned by three latching arms. The PIU absorbs any positioning error, and keeps the necessary position and accuracy for on-orbit mating with the active-side of the PIU.
3. Mate/de-mate functions of JEM-EF resources – the PIU simultaneously provides the mating and de-mating capability for physically interfacing, using robotics, the payload with JEM-EF.
4. PIU protection – to protect the quick-disconnect connectors from the exposed space environment, the PIU provides a protective cover which automatically opens during the robotic mating sequence.
5. JEM-EF resources/accommodations interface – the PIU provides payloads with power, data, and coolant resource and accommodations interfaces.

The proposer should be cognizant of the following important interfaces between the PIU and their payload. If a proposer determines the need for additional interface or design-to details, the following provide appropriate interface references from NASDA-ESPC-3122.<sup>19</sup>

- (a) Mechanical – Figure 4.2.1-2 to Figure 4.2.1-5 provide an overview of the PIU and payload structural interface envelope. For detailed assembly drawings, refer to Appendix 3 of NASDA-ESPC-3122.<sup>19</sup>
- (b) Electrical – Refer to Appendix 3, Table 3-5, 3-6. The references for heaters are contained in NASDA-ESPC-3122, Appendix 3, Table 3-7.<sup>19</sup>
- (c) Thermal – In addition to the criteria contained in Paragraph 4.2.3, Thermal, of the Guide, please note that the allowable interface surface temperature of the PIU is 60 °C on the ground, and –54 to 82 °C on-orbit.
- (d) Fluid – The PIU Type A reference, which many proposers will elect to use as it contains the fluid interface, is contained in NASDA-ESPC-3122, Appendix 3 in greater detail.<sup>19</sup>
- (e) Robotic – Please refer to NASDA-ESPC-3122, Appendix 3, Tables 3-8, 3-9, and 3-10 for additional information for robotic attachment details.<sup>19</sup>  
Remember, the PIU requires a GF for robotic manipulation, which should be included in your payload mass and envelope calculations.

The PD must provide a structural interface “box” or platform that is capable of interfacing with the PIU, GF SpaceX-provided equipment for structurally interfacing with the Dragon, and an electrical connector (provided by SpaceX) that attaches to the Dragon power connector. The maximum payload envelope that the PD-developed structural interface hardware must fit within, is provided in Figures 4.2.1-2 and 4.2.1-3. The PD should contact the ISS RIO for the latest SpaceX/Dragon interface configuration(s).

NOTE: The natural frequency requirements of the EF Experimental Payload is  $\geq 5$  Hz for a standard payload (<500 kg) or  $\geq 2$  Hz for heavy payloads (500–1500 kg, positions 2, 9, and 10), when fixed at the PIU mating surface in all directions.



**FIGURE 4.2.1-2 JEM-EF TYPICAL CONFIGURATION**

The PIU, required for all JEM-EF payloads, is supplied by NASA to the PD community, and is represented in Figures 4.2.1-2 to 4.2.1-5. In addition, the following PIU accessories are generally included with PIU usage:

- PIU structural template assembly
- PIU attachment bolts, including spares
- PIU transportation and storage containers
- PIU adapter plate
- Passive flight support equipment (supplied by SpaceX upon request)

The standard payload envelope and location of the required GF are shown in Figure 4.2.1-4, Standard Payload Envelope and Location of the Required GF.

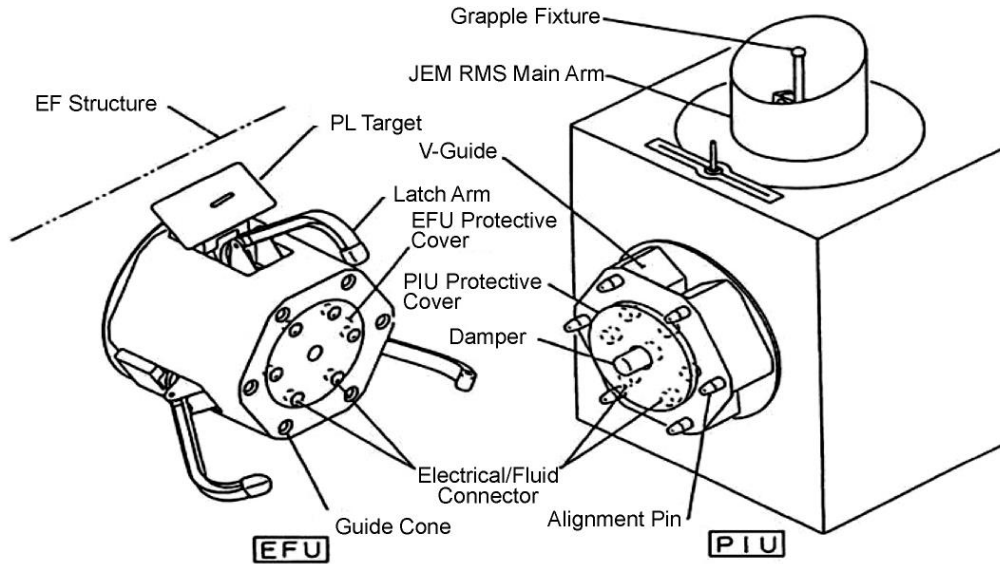
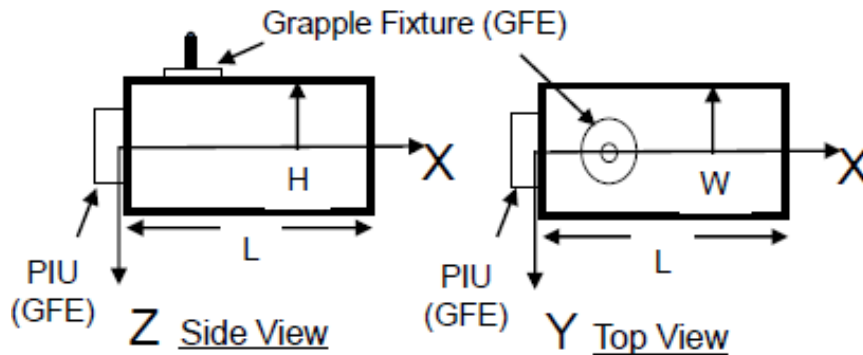


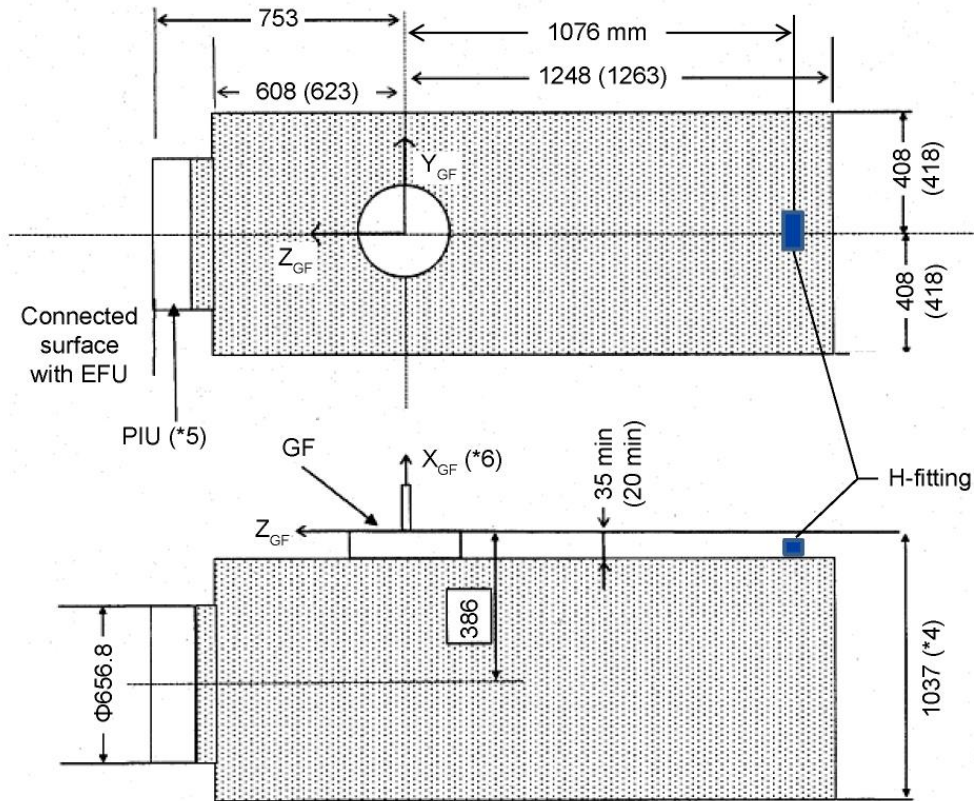
FIGURE 4.2.1-3 PAYLOAD INTERFACE UNIT



Axis	mm	ft	inch
W	800	2	7.50
H	1000	3	3.37
L	1850	6	0.83

FIGURE 4.2.1-4 STANDARD PAYLOAD ENVELOPE AND LOCATION OF THE REQUIRED GF

Figure 4.2.1-5, PIU Standard Envelope and GF illustrates the PIU standard envelope, with a standard GF attached.



Unit ; (mm)

- (\*1) The envelope (hatched area) is defined with respect to the origin of GF coordinate.
- (\*2) All are the maximum values (including manufacturing tolerances and thermal deformation) except for standard dimensions and the dimensions specified in "min."
- (\*3) The values in brackets are dimensions including MLI.
- (\*4) Includes attachment mechanism to a carrier for launch and recovery.
- (\*5) The dimension of PIU shall be referred to using NASDA-ESPC-3122.<sup>19</sup>
- (\*6) The details of GF can be found in NASDA-ESPC-2901, JPAH Vol. 4: JEM Manipulator/Payload Interface Control Document.<sup>18</sup>

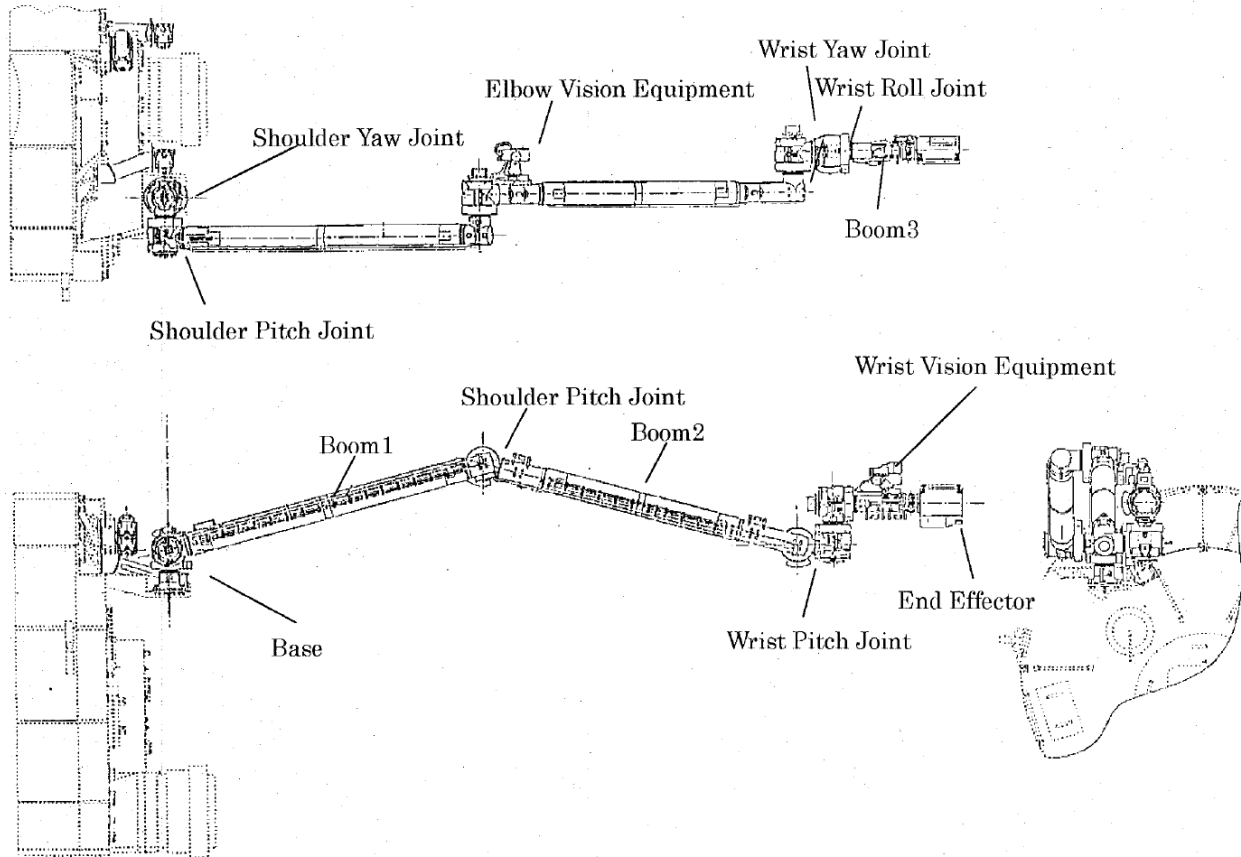
**FIGURE 4.2.1-5 PIU STANDARD ENVELOPE AND GF**

## 4.2.2 ROBOTICS

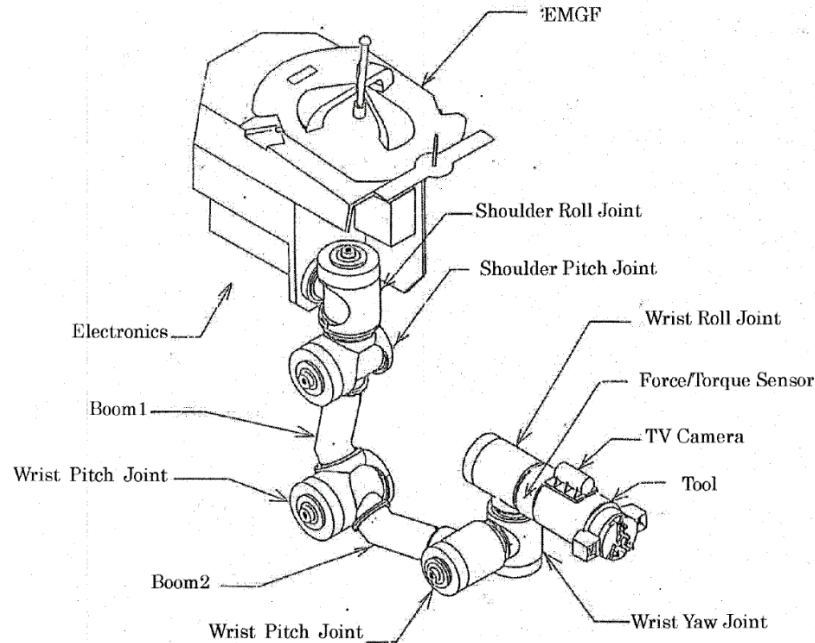
The JEM-EF is serviced by a combination of the ISS robotics system and the Japanese supplied KiBO arm, which is used for JEM-EF only. The JEM's Remote Manipulator System (JEM-RMS) is a robotic manipulator system used to support experiments and logistics conducted on JEM-EF. It is composed of two arms, the Main Arm (MA) (Figure 4.2.2-1, JEM-EF MA Configuration) and the Small Fine Arm (SFA) (Figure 4.2.2-2, SFA Configuration). The MA is used to handle (move, position, berth, de-berth, or maintain position) a large payload and the SFA is used for small items and dexterous tasks.

Payloads that are brought up on the SpaceX Dragon are removed from Dragon and translated to the JEM using the ISS Dextre. (Details of the Dextre robot are provided in Paragraph 4.1.3 of this Guide.) The payload is then grappled by the JEM MA at the FRGF. It is then released by the Dextre OTCM, transferred to the KiBO and then installed by the JEM MA. Upon installation onto JEM, the payload will have survival heater power from JEM, which is a different circuit at a different voltage and allowable

power level from Dragon. Analysis must show payload survival without power for at least 7 hours.



**FIGURE 4.2.2-1 JEM-EF MA CONFIGURATION**



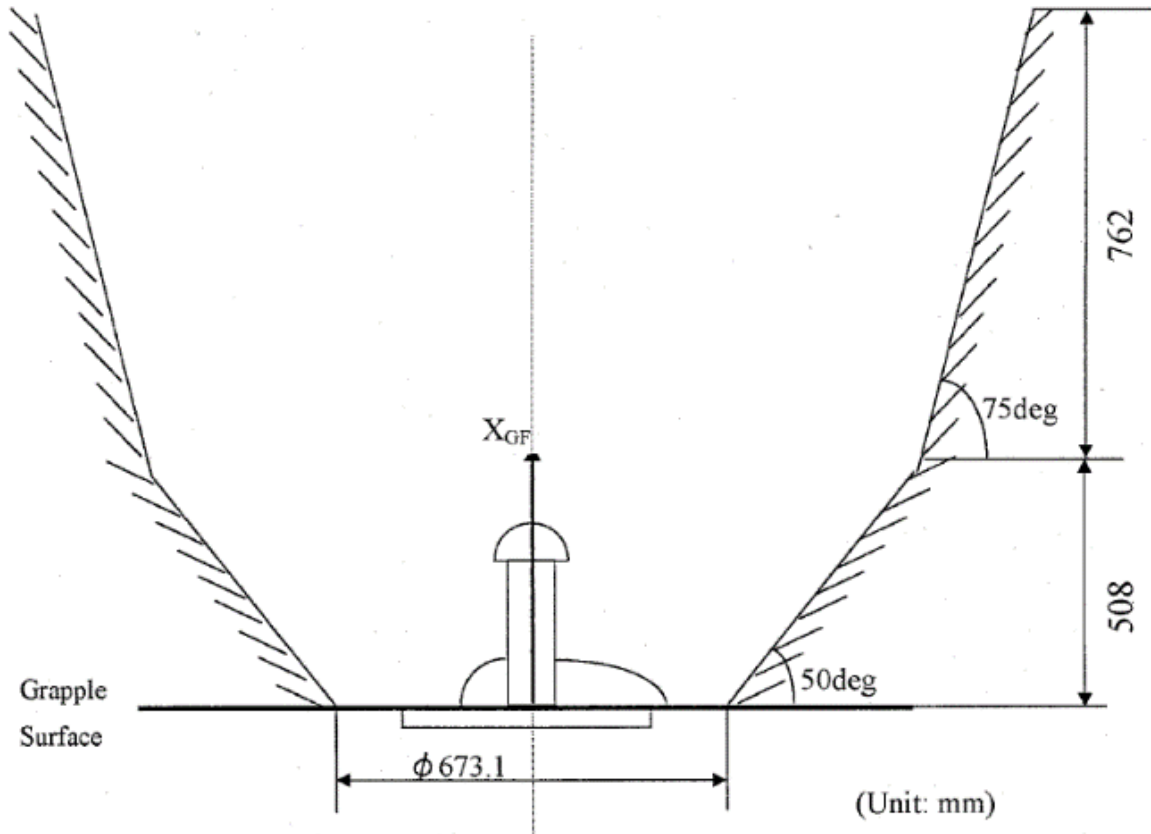
**FIGURE 4.2.2-2 SFA CONFIGURATION**

All JEM-EF payloads must have a GF that matches the end effector in order for the JEM-RMS to handle the payload. The GF will be supplied by the ISS, but is mounted on a payload-supplied structural interface.

Payloads are grappled by the MA end effector which is the grapple mechanism at the end of the MA. The MA end effector can provide interfaces such as electric power supply, data, and video signals, but this requires the use of a special type of GF which is not readily available.

Clearance for the MA and payload grappling operation shall conform to the illustration in Figure 4.2.2-3, Illustration of Clearance for the MA and Payload Grappling Operation.





NOTE: If there is an object higher than 1270 mm, evaluation by element integrator is needed.

**FIGURE 4.2.2-3 ILLUSTRATION OF CLEARANCE FOR THE MA AND PAYLOAD GRAPPLING OPERATION**

In all cases, the payload interface design is defined and controlled by NASDA-ESPC-2901.<sup>18</sup> The PIU dynamic envelope is shown in Figure 4.2.2-4, PIU Dynamic Envelope.

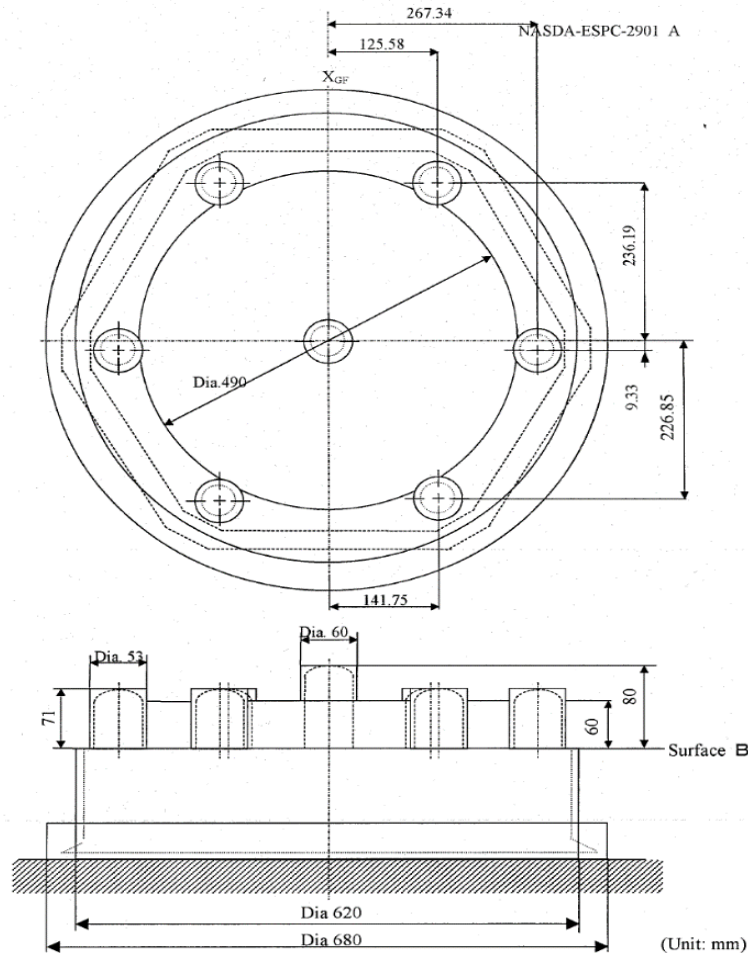


FIGURE 4.2.2-4 PIU DYNAMIC ENVELOPE

### 4.2.3 THERMAL

The thermal interface between the JEM-EF and the experiment payload consists of the Passive Thermal Control System (PTCS) and the Active Thermal Control System (ATCS). There are two thermal system design options available to a payload proposer and each works through a passive half of a PIU mounted on your payload and a corresponding active half attached to the JEM-EF platform. A Type B or Type B-EP PIU have no fluid interface, whereas type A or type A-EP do. The proposer should consider the details involved with either the ATCS/PIU type A or the PTCS/PIU type B, which may require different plumbing hardware configurations within their payloads to meet ISS system requirements. The thermal characteristics related to the PIU are defined in NASDA-ESPC-3122.<sup>19</sup> Proposers would need to prepare a math model utilizing the PTCS or the ATCS for a thermal analysis in accordance with JFX-2000073.<sup>10</sup> These analyses need to be submitted to the ISS element integrator for considering interactions with other payloads.

#### 4.2.3.1 PASSIVE THERMAL CONTROL SYSTEM (PTCS) INTERFACE

The PTCS interface consists of heat radiation from the outer surfaces of the EF and of other experiment payloads and heat conduction between the EFU and a type B PIU. There is no fluid coolant in PTCS. The outer surfaces of a proposer's payload that could have heat radiation with the EF and/or with the other EF experiment payloads should be covered with MLI (thermal blanket). The MLI thermal characteristics the proposer should utilize in their design analysis are defined in Table 4.2.3-1, Thermal-Optical Characteristics of Experiment Payload Outer Surfaces. The interface analysis for heat radiation cannot have heat conductance influence on the EF system.

The thermal conduction design portion for the PTCS is the consideration of heat flow across the EFU to the type B PIU contact interface. The interface surface temperature should fall between  $-45$  and  $+65$  °C, from the moment of EFU/PIU contact, with an EFU/PIU thermal conductance of  $10 \pm 5$  [W/K]. In addition, the temperature difference shown by thermal analysis (supported by ISS Element Integrator) between the interface surfaces of EFU and PIU prior to the mating needs to be less than or equal to  $80$  °C.

Waste heat generated by your proposed payload shall be absorbed and transported by PTCS to minimize the thermal interference between the EF and experiment payload. Heaters are permitted on the payload to preserve the thermal design. The heater power interface provided from the EF is defined in the power interface in Paragraph 4.2.4, Power, of this Guide.

**TABLE 4.2.3-1 THERMAL-OPTICAL CHARACTERISTICS OF EXPERIMENT PAYLOAD OUTER SURFACES**

Item	Characteristic value
MLI effective emittance	$\epsilon_{\text{eff}} \leq 0.04$
MLI thermo-optical characteristics	$\alpha = 0.31 - 0.6$ $\epsilon = 0.85 - 0.96$

#### 4.2.3.2 ACTIVE THERMAL CONTROL SYSTEM (ATCS) INTERFACE

This system involves the use of coolant supplied from the JEM-EF through a piping system through a PIU type A or type A-EP to your payload. The ATCS supplies and collects coolant that absorbs and carries the waste heat away from the proposed payload through the fluid connector of the EEU. A payload ATCS fluid schematic is seen in Table 4.2.3.2-2, Differential Pressure and Schematic. Coolant is not supplied to a payload when it is not operating, so the coolant is not to be considered as the heat source for preserving your proposed payload. Coolant information is available in physical properties of Fluorinert (FC-72-perfluorocarbon) and SSP 30573, Space Station Program Fluid Procurement and Use Control Specification.<sup>33</sup>

### Coolant Supply Characteristics Summary

Table 4.2.3.2-1, ATCS Fluid Interface Coolant Supply Characteristics, outlines parameters of the ATCS coolant fluid supplied to your payload. The coolant system is the key difference that sets the ATCS apart from the PTCS. The coolant temperatures and flow rates cited are those once the operational conditions of the ATCS fluid loop are stabilized for the JEM-EF payloads (stabilized means after a startup time or configuration change). These will depend on the ISS JEM-EF platform operation and configuration (the number of payloads, attached location, heat rejection, etc.), and could even deviate somewhat from these ranges. The interface coolant flow rate is based on a unit heat rejection (including the influence of the payload attaching position). The return coolant temperature range cited is considered acceptable for a payload if it meets three criteria outlined in NASDA-ESPC-2900A.<sup>17</sup> These have to do with the required coolant outlet temperature from your payload to the EF, a maximum amount of coolant warm up from the payload, and a required minimum temperature of the coolant back into the EF. The payload proposer should confirm all of this with the element integrator for his payload.

The Maximum Design Pressures (MDP), excluding water hammering, cited in Table 4.2.3.2-1 is guaranteed to your payload based on a two-fault failure internal EF design when there are no factors or no failures that raise the payload internal pressure. The maximum pressure increase allowed in your payload is 392 kPa (4.0 kgf/cm<sup>2</sup>d) when water hammering occurs. Payload proposers should configure their payload fluid system so that the pressure drop in their payload excluding the PIU, ranges from 52.4 to 57.8 kPa when the flow rate is 190 kg/h (Table 4.2.3.2-1). The system level pressure drop is ultimately controlled by the EF system through flow control and the actual measured pressure drop tolerance during testing will be considered for verification purposes. Lastly, the fluid pressure in a payload during berthing operation to JEM-EF shall be 785 kPa (8.0 kg/cm<sup>2</sup>A) or less.

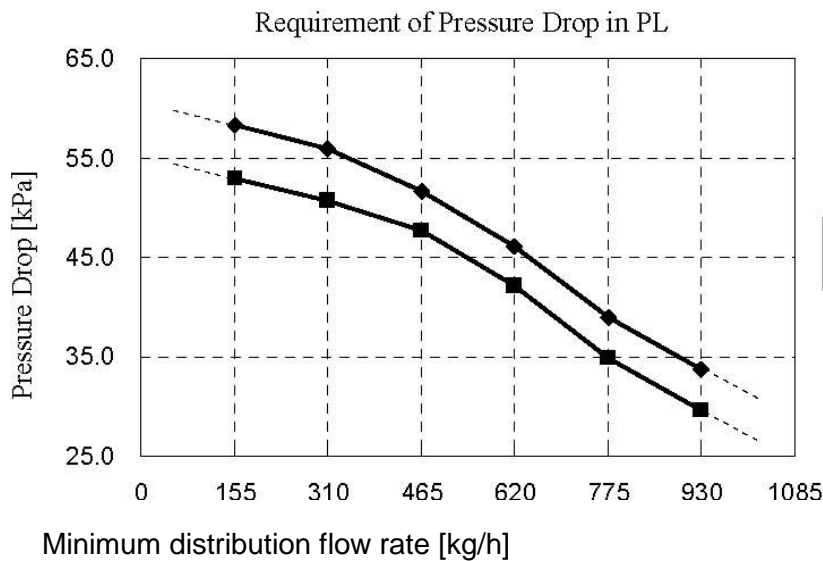
You will need to set the amount of flow rate in your payload to correspond to the maximum payload heat rejection required with a pressure drop based on the Tables 4.2.3.2-1 and 4.2.3.2-2 and shown in Figure 4.2.3.2-1, Coolant Pressure Drop Required In Experiment Payload. You should not consider the absorption of heat from the coolant, but instead consider it only for its heat rejection. The amount of heat leakage from the coolant interface heat flow from the coolant loop to the payload in the nominal operation and during non-operation\* after one failure, should not exceed 49 W.

---

\* This is the case that the main electrical power is shutdown while coolant loop flow to the payload remains flowing.

**TABLE 4.2.3.2-1 ATCS FLUID INTERFACE COOLANT SUPPLY CHARACTERISTICS**

Interface Parameter	Coolant Temperature		Max. Allowable Heat Rejection of Experiment Payload, W	Provided Coolant Flow Rate, kg/hr	Coolant Pressure under nominal operation, MPa (kgf/cm <sup>2</sup> A)	Coolant Maximum Design Pressure in system, MPa (kgf/cm <sup>2</sup> A)
	Supplied Coolant Temperature to Experiment Payload, °C	Returned Coolant Temperature from Experiment Payload, °C				
	16 – 24	16 – 50	900	190 + 18% / -0%	No higher than 0.78 (8.0)	1.57 (16.0)



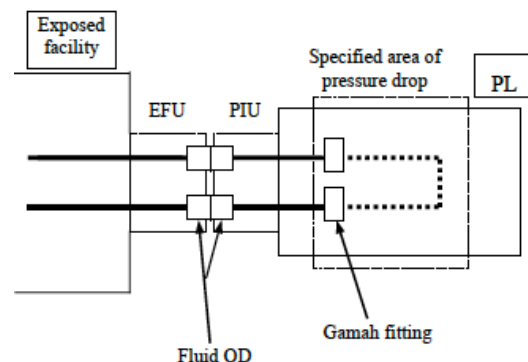
**FIGURE 4.2.3.2-1 COOLANT PRESSURE DROP REQUIRED IN EXPERIMENT PAYLOAD**

Differential pressure is specified in Table 4.2.3.2-2, Differential Pressure and Schematic.

**TABLE 4.2.3.2-2 DIFFERENTIAL PRESSURE AND SCHEMATIC**

(NOTE THAT THE PRESSURE DROP IN THE PIU IS NOT INCLUDED)

Heat rejection, kW	Minimum distribution of flow rate, kg/h	Pressure Drop, kPa (kgf/cm <sup>2</sup> D)	
		Minimum	Maximum
1	155	52.9 (0.540)	58.4 (0.595)
2	310	50.7 (0.517)	55.9 (0.570)
3	465	47.7 (0.486)	51.7 (0.528)
4	620	42.1 (0.429)	46.1 (0.470)
5	775	34.9 (0.356)	39.0 (0.398)
6	930	29.6 (0.301)	33.8 (0.344)



NOTE: As coolant rate is a shared resource among the JEM-EF payload complement, the maximum design coolant flow rate allowable for any JEM-EF payload is 155 kg/h. If your proposal exceeds this amount, please contact the ISS program for additional information and assessment.

Experiment Payload ATCS Design Requirements

Payloads being proposed with fluid systems that will interface with the ATCS fluid loop of the EF will need to address coolant pressures, cleanliness, capacity, and temperature. Cleanliness requirements are contained in Table 4.2.3.2-3, Cleanliness Requirements for Experiment Payload Fluid Systems. The capacity of the fluid system with the coolant inside of a proposers' payload is 2.0 L or less including the PIU. This capacity excludes a second loop in the payload without a direct interface to EF-ATCS (fluid loop). A filter with the mesh size of 40 µm or smaller is recommended to be installed at the outlet of your payload ATCS loop. Coolant external leakage from the overall plumbing inside your payload is specified in Table 4.2.3.2-4, Allowable Leak for Experiment Payload, while that of the PIU itself is described in NASDA-ESPC-3122.<sup>19</sup>

**TABLE 4.2.3.2-3 CLEANLINESS REQUIREMENTS FOR EXPERIMENT PAYLOAD FLUID SYSTEMS**

Particle size, µm	Maximum allowable number per 100 ml test fluid *1
0 – 5	Unlimited
6 – 10	3600
11 – 25	1050
26 – 50	210
51 – 100	20*2
101 – 250	2
251 or over	Not allowed

\*1. Fiber is included. Note that “fiber” means a non-metallic particle whose length is 100 µm or longer and whose length/ diameter ratio is 10/1 or less.

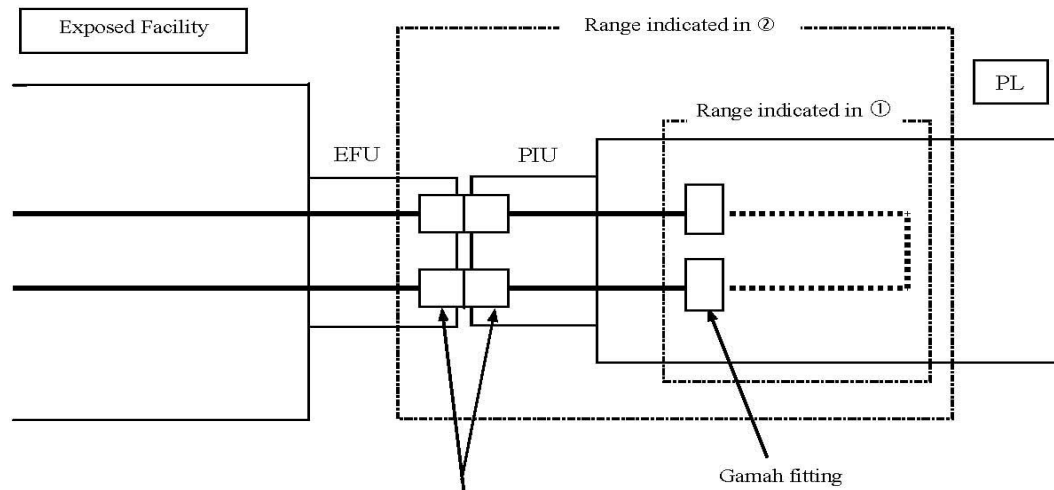
\*2. Note that no metallic particle whose length is 51 µm or longer is allowed.

Note 1. The volume of test (sampling) fluid is 100 ml for the unit area 0.093 m<sup>2</sup> (1 ft<sup>2</sup>) of required inner surface area. Note that the volume of test fluid is 100 ml when the required inner surface area is less than 0.093 m<sup>2</sup> (1 ft<sup>2</sup>).

Note 2. The cleanliness of test fluid (maximum allowable number of particles) shall be 1/10 of the objective level or less.

TABLE 4.2.3.2-4 ALLOWABLE LEAK FOR EXPERIMENT PAYLOAD

	Allowable leak	Remarks
① Fluid QD not included	$1.01 \times 10^{-6}$ [Pa·m <sup>3</sup> /s] @ 1.18 [MPa] ( $1 \times 10^{-5}$ [sccsGHe : @ 12kgf/cm <sup>2</sup> A])	Including the leak in the Gamah fitting
② Fluid QD included (Reference data)	$3.04 \times 10^{-6}$ [Pa·m <sup>3</sup> /s] @ 1.18 [MPa] ( $3 \times 10^{-5}$ [sccsGHe : @ 12kgf/cm <sup>2</sup> A])	-45 to +16 [°C]
	$7.09 \times 10^{-6}$ [Pa·m <sup>3</sup> /s] @ 1.18 [MPa] ( $7 \times 10^{-5}$ [sccsGHe : @ 12kgf/cm <sup>2</sup> A])	+16 to +65 [°C]
	$2.13 \times 10^{-5}$ [Pa·m <sup>3</sup> /s] @ 1.18 [MPa] ( $2.1 \times 10^{-4}$ [sccsGHe : @ 12kgf/cm <sup>2</sup> A])	+65 to +79 [°C]



Absorption equipment for pressure adjustment such as an accumulator in a proposed payload shall not be operated (not absorb coolant from the EF system) when the pressure is 471 kPa (4.8 kgf/cm<sup>2</sup>A) or less, at any thermal environment that the payload is exposed to. A payload proposed requires the ability to detect abnormally high-temperature of inflow/outflow coolant to be in a safe operating condition and limit heat rejection by itself. Abnormally high-temperature criteria are designated as “normal operating temperature +10 °C plus measurement errors” in the payload and will be controlled by commands from the ground.

The coolant supply from JEM-EF ATCS could stop for ISS system operating reasons. The payload proposer should configure his design to be capable of stopping safely to prevent hazards such as the destruction of the EF or other neighboring payloads due to the temperature increase. The proposer should design to prevent the destruction of his fluid system due to the increased pressure of the coolant internal to the plumbing, caused by temperature increases (i.e., equipping the accumulators of the system to absorb pressure increase). Proposers’ payload will need to be two-fault tolerant for any MDP (16.0 kgf/cm<sup>2</sup>A) exceedance.

### Visiting Vehicle Transfer

One challenge of experiment payload thermal control design is the safe survival of your payload during the 7-hour unpowered transfer of the payload from the visiting vehicle to the JEM-EF for berthing (as mentioned previously, the fluid pressure in your payload during berthing operation to JEM-EF needs to be 785 kPa (8.0 kg/cm<sup>2</sup>A) or less). It is important that your payload be thermally conditioned with the survival heater power supplied by the visiting vehicle before it is released. The payload will be powered once it is berthed to JEM-EF. The power from Dragon Visiting Vehicle is supplied at 120 Vdc and is limited to 200 W shared between all the external payloads in the launch vehicle trunk. The launch vehicle, its cargo bay, and the payload itself can be in a combination of orientations during the payload transfer. The thermal interface requirements are found in NASDA-ESPC-2900A.<sup>17</sup>

### Thermal Models

Key thermal considerations that must be addressed by the external PD are the development and delivery of a thermal model in required format and generation of thermal analyses to demonstrate that the payload will remain safe during LTA, as well as applicable on-orbit stowage sites on the ISS. These models will be provided to support required thermal assessment by the launch vehicle integrator and the ISS vehicle integrator.

The external PD will be required to develop and deliver a thermal model compatible with Thermal Desktop<sup>®</sup> and TRASYS/SINDA. The model is expected to be comprised of no more than 500 geometric and 500 mathematical nodes that represent all geometric and material properties required for determining critical hardware temperatures. These models will be utilized by the PD to assess the external payload in its on-orbit configuration, including the time periods while stowed in the launch vehicle and on the ISS JEM-EF. These models will be provided to the ISS Program in order to support required thermal assessments by the launch vehicle integrator and the ISS vehicle integrator.

### Thermal Analysis

The external attached payload must remain safe during the LTA phase while stowed in the launch vehicle, as well as during the subsequent phase while it is stowed on an ISS ELC when it is exposed to a space sink temperature of 3 K, the thermal environment parameters defined in Table 4.2.3.2-5, Thermal Environment Parameters, the ISS flight attitudes and solar beta angle ranges defined in Table 4.2.3.2-6, ISS Flight Attitudes (similar attitude requirements will be defined for the applicable launch vehicle) and the thermal interactions with all other on-orbit hardware. Verification of safe operation will require PD generated thermal analysis using ISS Program provided launch vehicle and ISS thermal models integrated with a PD developed thermal model of the proposed payload.



**TABLE 4.2.3.2-5 THERMAL ENVIRONMENT PARAMETERS**

Case	Solar Constant (W/m <sup>2</sup> )	Earth Albedo	Earth OLR (W/m <sup>2</sup> )	Altitude (km)
Cold	1321	0.2	206	500
Hot	1423	0.4	286	278

**TABLE 4.2.3.2-6 ISS FLIGHT ATTITUDES**

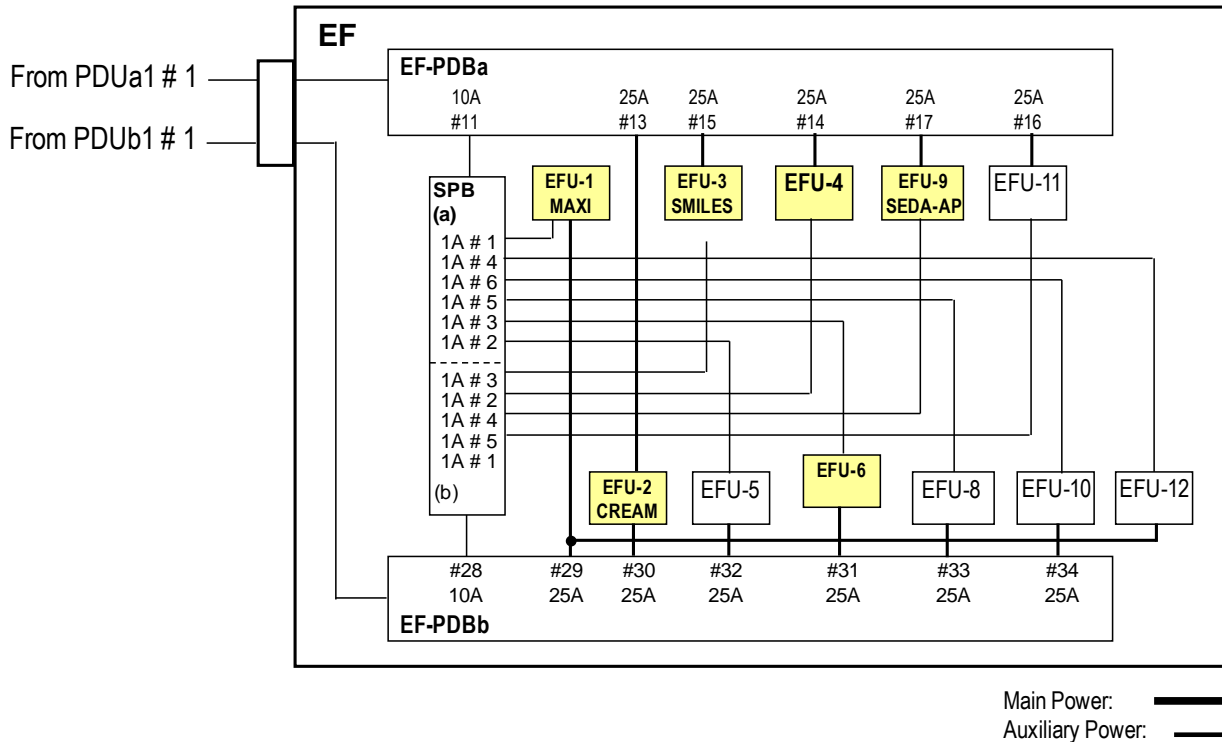
ISS Attitude Name	Attitude Reference Frame	Solar Beta Range ( $\beta$ )	Yaw	Pitch	Roll	Time in Attitude
+XVV +Z Nadir	LVLH	$-75^\circ \leq \beta \leq +75^\circ$	$-15^\circ$ to $+15^\circ$	$-20^\circ$ to $+15^\circ$	$-15^\circ$ to $+15^\circ$	No Limit
-XVV +Z Nadir	LVLH	$-75^\circ \leq \beta \leq +75^\circ$	$+165^\circ$ to $+195^\circ$	$-20^\circ$ to $+15^\circ$	$-15^\circ$ to $+15^\circ$	No Limit
+YVV +Z Nadir	LVLH	$-75^\circ \leq \beta \leq +10^\circ$	$-110^\circ$ to $-80^\circ$	$-20^\circ$ to $+15^\circ$	$-15^\circ$ to $+15^\circ$	No Limit
-YVV +Z Nadir	LVLH	$-10^\circ \leq \beta \leq +75^\circ$	$+75^\circ$ to $+105^\circ$	$-20^\circ$ to $+15^\circ$	$-15^\circ$ to $+15^\circ$	No Limit
+ZVV -X Nadir	LVLH	$-75^\circ \leq \beta \leq +75^\circ$	$-15^\circ$ to $+15^\circ$	$+75^\circ$ to $+105^\circ$	$-15^\circ$ to $+15^\circ$	3 Hours
-ZVV -X Nadir	LVLH	$-75^\circ \leq \beta \leq +75^\circ$	$+165^\circ$ to $+195^\circ$	$+75^\circ$ to $+105^\circ$	$-15^\circ$ to $+15^\circ$	3 Hours

#### 4.2.4 POWER

##### Operational Power

JEM-EF electrical power is supplied at a maximum of 3 kW for main (primary) power and maximum 1.2 kW for auxiliary (survival) power as shown in Figure 4.2.4-1, Electric Power Configuration in the JPM. The normal voltage range for main power is 112.5 to 126 Vdc and for auxiliary power is 110.5 to 126 Vdc.

NOTE: JEM-EF Power is a shared resource for all JEM-EF instruments operating simultaneously on that facility. The maximum design power allowable for any instrument operating on JEM-EF is 500 W. If your proposal exceeds this amount, please contact the ISS Program for additional information and assessment.



**FIGURE 4.2.4-1 ELECTRIC POWER CONFIGURATION IN THE JPM**

Survival Heater

Survival heater may be supplied, also, with a channel separated from the experiment channel, and can provide a maximum 120 W at 120 Vdc.

Figure 4.2.4-1 also illustrates the power and data connections between the JEM-EF facility and the PIU/payload.

**4.2.5 COMMAND AND DATA HANDLING (C&DH)**

Each payload has the following signal interfaces for the supported C&DH functions (see Figure 4.2.5-1, Power and Data Connections).

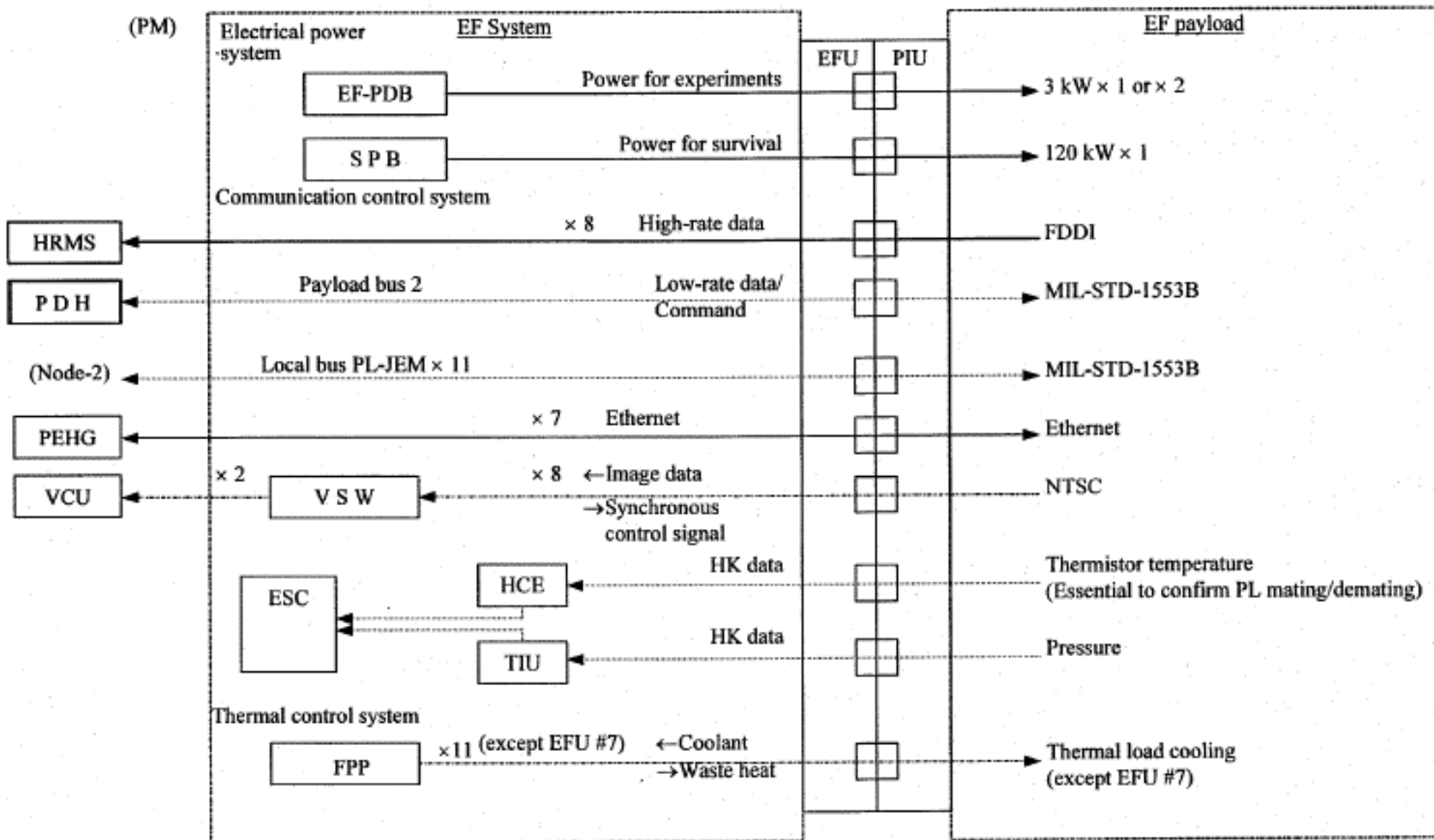


FIGURE 4.2.5-1 POWER AND DATA CONNECTIONS

### Low Rate Data Link

This is an extension of the payload MIL-STD-1553B<sup>14</sup> (20 kbps typical telemetry throughput) data bus primarily used for transmitting the commands to the payload and collecting the low-rate experiment data from the payload. The stub length must be no greater than 2 m, which includes the wiring inside the PIU and the payload equipment. This interface is not available at EFU #7, #10, #11, and #12

### Medium Rate Data Link (Wired)

This interface is part of the MRDL 10/100 Base T network which accommodates both U.S. payloads and JAXA payloads. The JAXA-supplied Layer 2 Ethernet Switch and Multiplexer (LEHX) provide a gateway for science data downlink. The Ethernet frame content conforms with the LEHX HRDL gateway Layer 2 format per SSP 52050 Rev. K, Paragraph 3.3.6.<sup>42</sup> This interface is only available for EFU #1, #2, #3, #6, #9, #11, and #12.

### Medium Rate Data Link (Wireless)

A MRDL path using a wireless Ethernet data link is available for JEM-EF payloads. It consists of a two-way high data rate communications link using RFs per IEEE 802.11n. This EWC system provides two-way data transfer between the payload sites and the PEHG in the USL. Data rates available to the payload are dependent upon the specific JEM-EF location.

*(Although NASA has completed a preliminary coverage map for the EWC System, this information is not included as assumptions made in generating the coverage map may not apply to the JEM-EF external payload utilizing the EWC. External payloads that will utilize the EWC should coordinate with NASA to obtain coverage information. The EWC user should refer to D684-14957-01, International Space Station (ISS) ELC Wireless Comm (EWC) User Guide,<sup>9</sup> for additional information).*

### High-Rate Data Link

This one-way high-rate data transmission path via optical fiber operates at an encoded signaling rate of 100 Mbps. It uses the protocol and varying data rates are achieved by parsing the data with sync symbols. There is one channel provided to each payload with the exception of EFU #7, #10, #11, and #12, where there is no such service provided. This has seen limited use, including the NASA Cloud-Aerosol Transport System (CATS) payload.

### Video System

A video interface is provided to each payload except for EFU #7, #10, #11, and #12. Due to ISS resource limitation, there are only two channels active for video transmission. As such, one channel will be shared by EFU #1, #4, #5, #8, while the other channel by EFU #2, #3, #6, #9. The video signal interface uses EIA-RS-170A, the National Television Systems Committee color television standard.

### Payload Housekeeping Data

There are two analog telemetry monitor channels for each payload interface. Each channel is implemented in primary and redundant signals pair for criticality. They are specifically used for monitoring the temperature and pressure of the payload respectively. The temperature and pressure are critical status monitors when the EF is in preservation mode of operation and/or during the EFU/PIU berthing activities.

#### **4.2.6 WIRELESS CAPABILITY**

Refer to Paragraph 3.1.2 for wireless capabilities.

#### **4.2.7 FIELD OF VIEW (FOV)**

The following provides the proposer a series of fish-eye images of the FOV from those JEM-EF locations available to hosted NASA external payloads, see Figure 4.2.7-1, JEM-EF EFU Locations and Orientations. EFU locations 1 through 6, and 8, through 12 are available for payload use. EFU Location 7 is reserved for system use. For each available payload location, a generic payload volume was used, reference Figures 4.2.7-2, JEM-EF Payload Volume Locations and Orientations and 4.2.7-3, JEM-EF EFU Payload Volume Locations and Orientation. A height (Z-axis dimension for EFU1 through EFU9) of 40 inches and a width (Y-axis dimension for EFU1 through EFU8 and X-axis dimension for EFU9) of 33 inches were used to create the payload volumes. The payload volume dimensions used for the EFU11 payload and the payload volume length (X-axis dimension for EFU1 through EFU8 and Y-axis dimension for EFU-9) are unknown. The viewpoint location for the Forward (ram) images for EFU1 through EFU8 was the center of each payload volume face normal to that direction. The viewpoint location for the Nadir and Zenith images for EFU1 through EFU8 was the point 63.64 inches away from the payload interface plane along the center of each payload volume face normal to the image direction. The viewpoint location for the Forward (ram), Nadir and Zenith images for EFU9 was the point 102.64 inches away from the payload interface plane along the center of each payload volume face normal to the image direction. The viewpoint location for the Forward (ram) image for EFU11 was the center of the payload volume face normal to that direction. These images were generated by the MAGIK Team software tools, at ISS/JSC (see Figures 4.2.7-4 through 4.2.7-18). The solid objects in the FOV remain there at all times while the pink shaded areas in the FOV represent the areas swept by the ISS solar (photovoltaic) arrays as they track the sun. A summary of these fish-eye FOV images is provided in Table 4.2.7-1, Summary of these Fish-Eye FOV Images.

TABLE 4.2.7-1 SUMMARY OF THESE FISH-EYE FOV IMAGES

Carrier	Location	Optimum Viewing Directions	ISS Aft FOV	ISS Forward FOV	ISS Nadir FOV	ISS Zenith FOV
JEM-EF	EFU1	Ram/Nadir/Zenith		✓	✓	✓
JEM-EF	EFU2	Nadir/Zenith			✓	✓
JEM-EF	EFU3	Ram/Nadir/Zenith		✓	✓	✓
JEM-EF	EFU4	Nadir/Zenith			✓	✓
JEM-EF	EFU5	Ram/Nadir/Zenith		✓	✓	✓
JEM-EF	EFU6	Nadir/Zenith			✓	✓
JEM-EF	EFU8	Nadir/Zenith			✓	✓
JEM-EF	EFU9	Ram/Nadir/Zenith		✓	✓	✓
JEM-EF	EFU10	Nadir/Zenith			✓	✓
JEM-EF	EFU11	Ram/Zenith		✓		✓
JEM-EF	EFU12	Zenith				✓

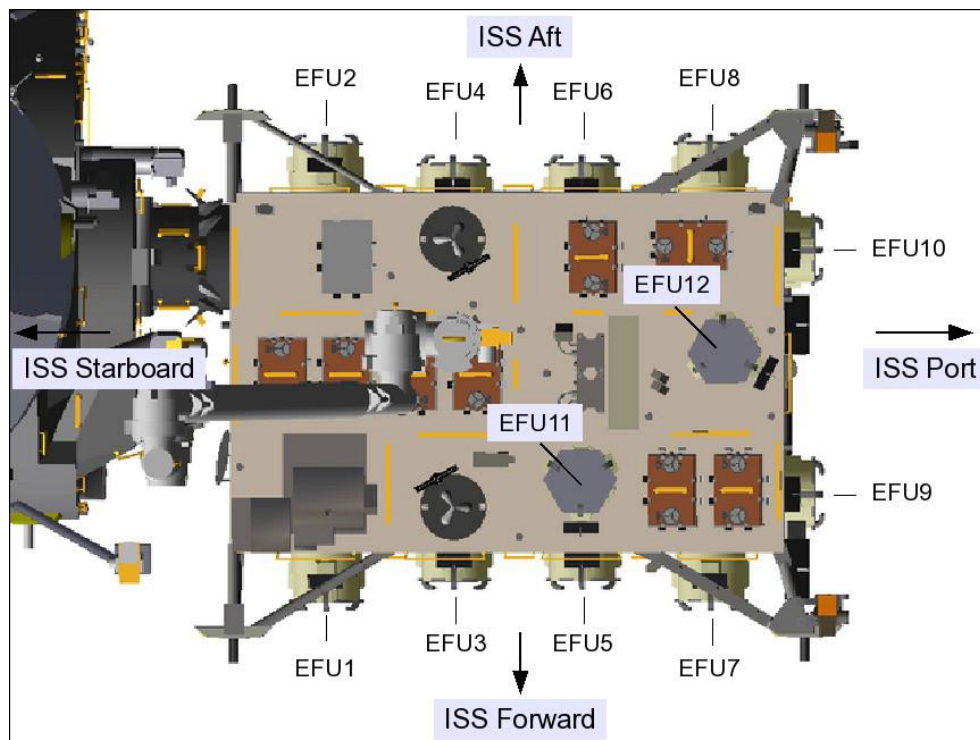


FIGURE 4.2.7-1 JEM-EF EFU LOCATIONS AND ORIENTATIONS

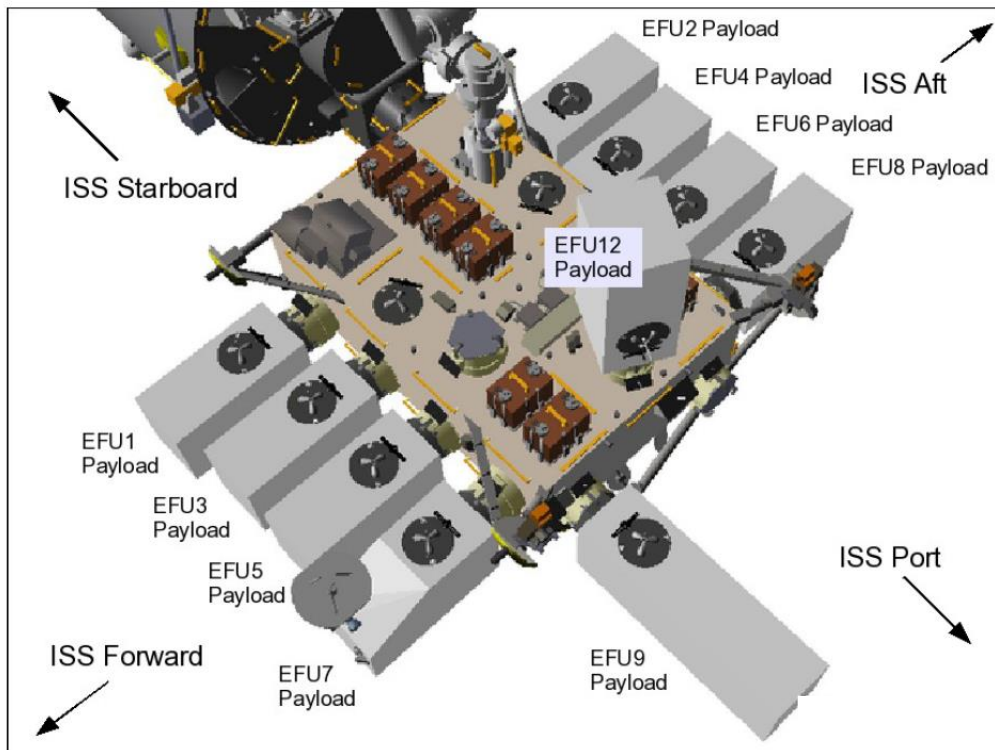


FIGURE 4.2.7-2 JEM-EF PAYLOAD VOLUME LOCATIONS AND ORIENTATIONS

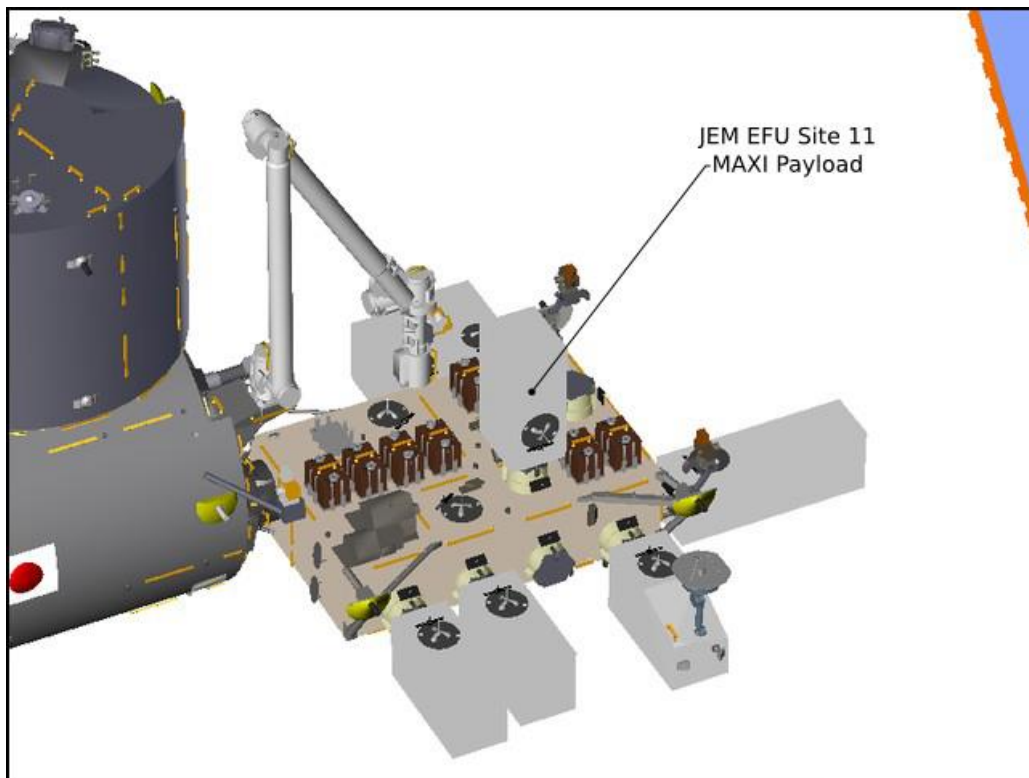
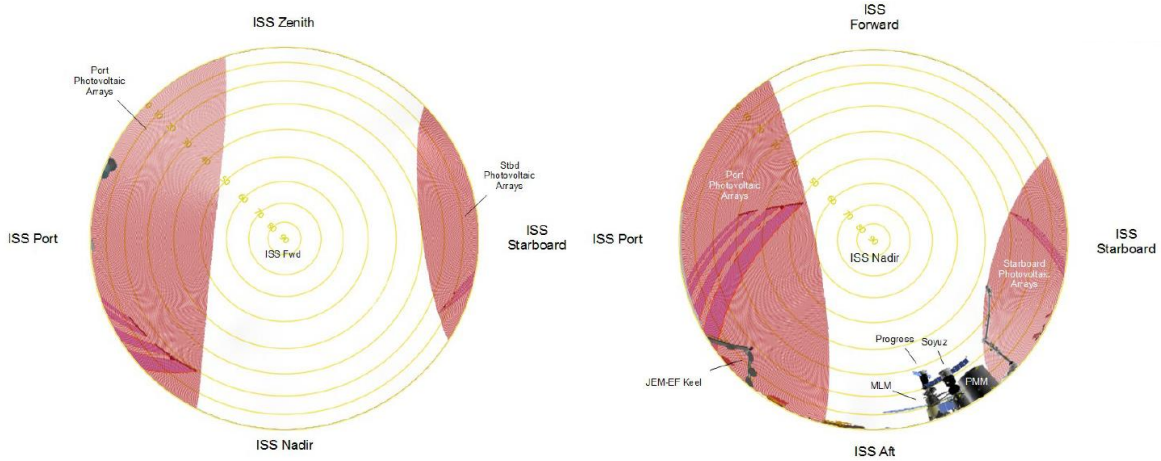
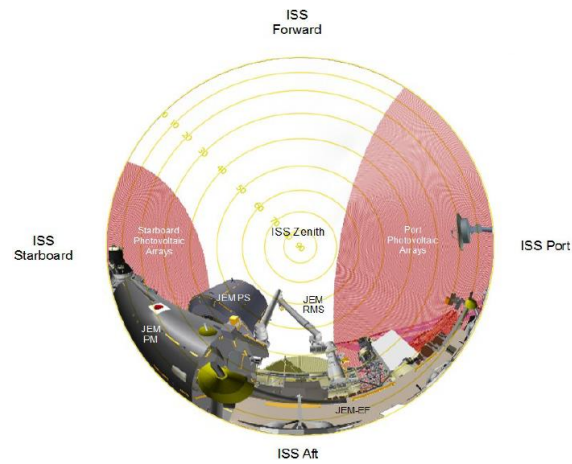


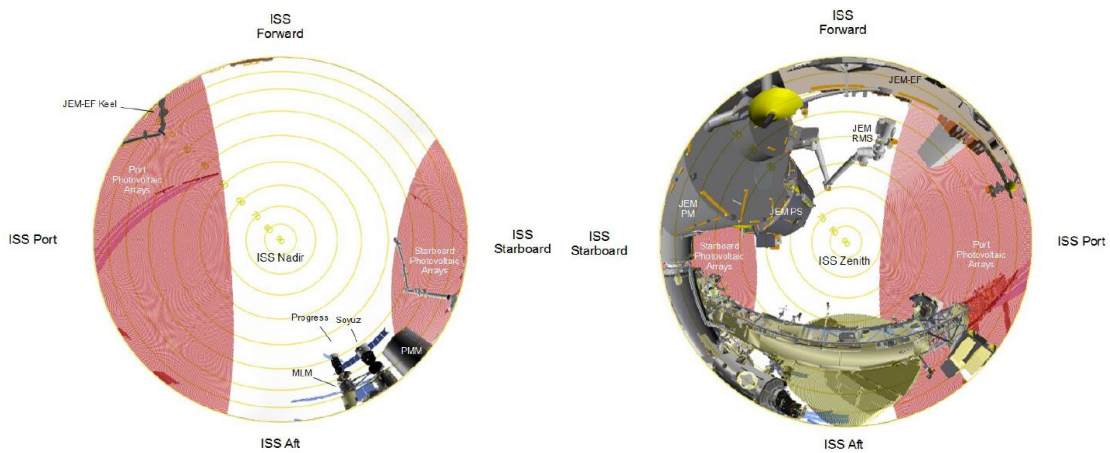
FIGURE 4.2.7-3 JEM-EF EFU PAYLOAD VOLUME LOCATIONS AND ORIENTATION



**FIGURE 4.2.7-4 JEM-EF EFU1 PAYLOAD ACCOMMODATION FORWARD (RAM) AND NADIR)**

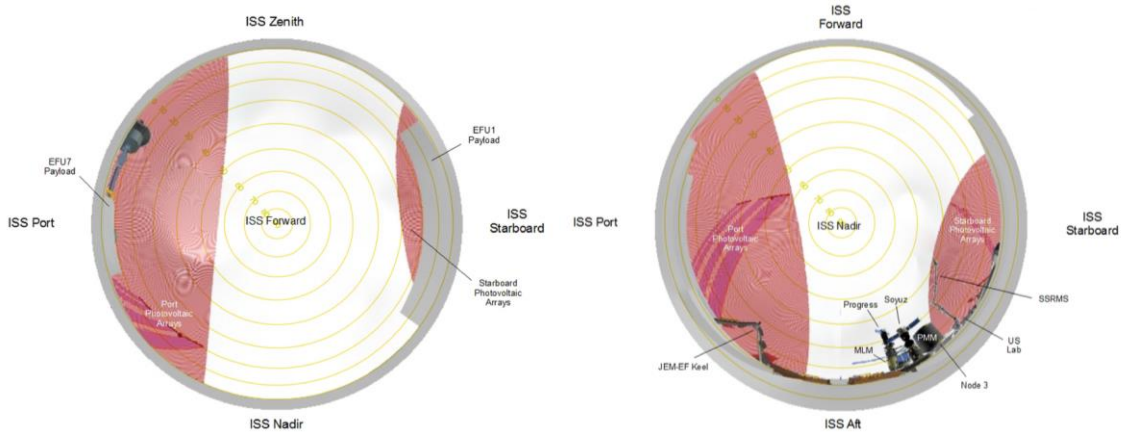


**FIGURE 4.2.7-5 JEM-EF EFU1 PAYLOAD ACCOMMODATION ZENITH**

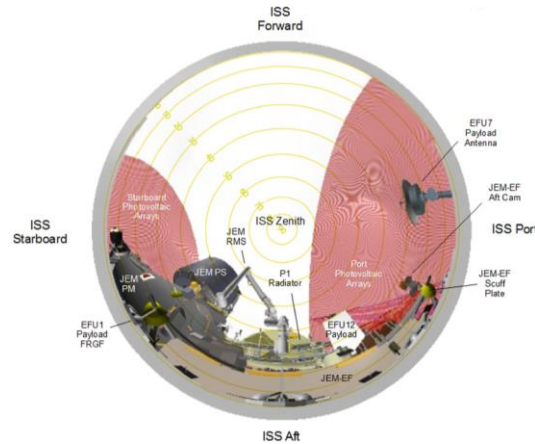


**FIGURE 4.2.7-6 JEM-EF EFU2 PAYLOAD ACCOMMODATION NADIR AND ZENITH**

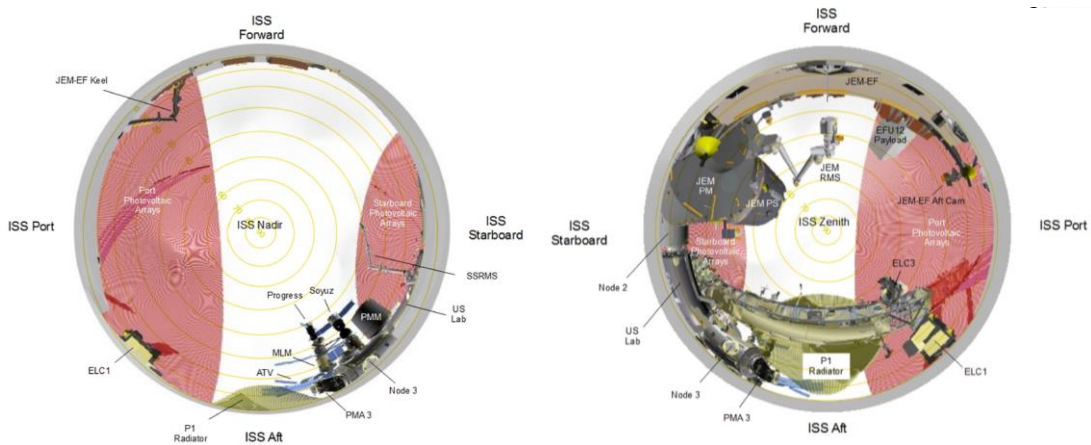




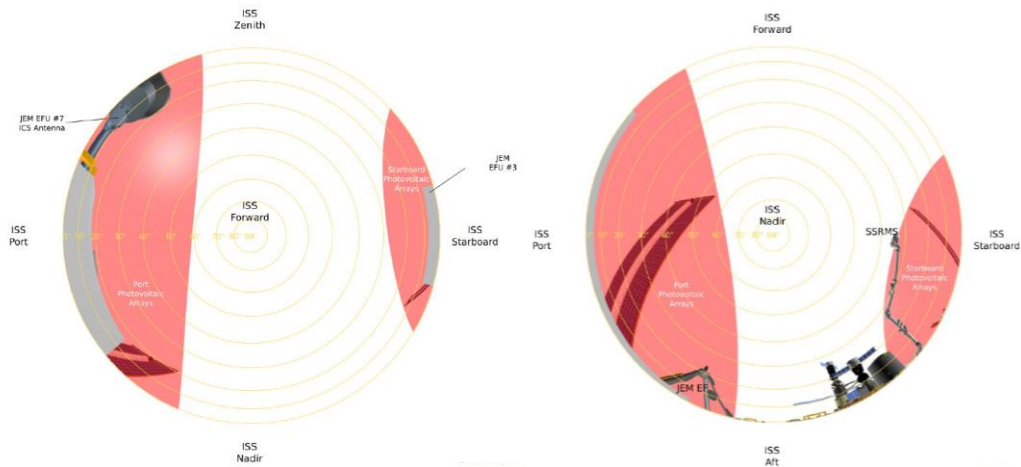
**FIGURE 4.2.7-7 JEM-EF EFU3 PAYLOAD ACCOMMODATION FORWARD (RAM) AND NADIR)**



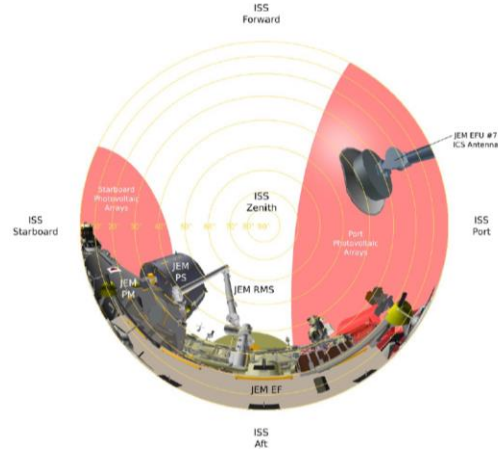
**FIGURE 4.2.7-8 JEM-EF EFU3 PAYLOAD ACCOMMODATION ZENITH**



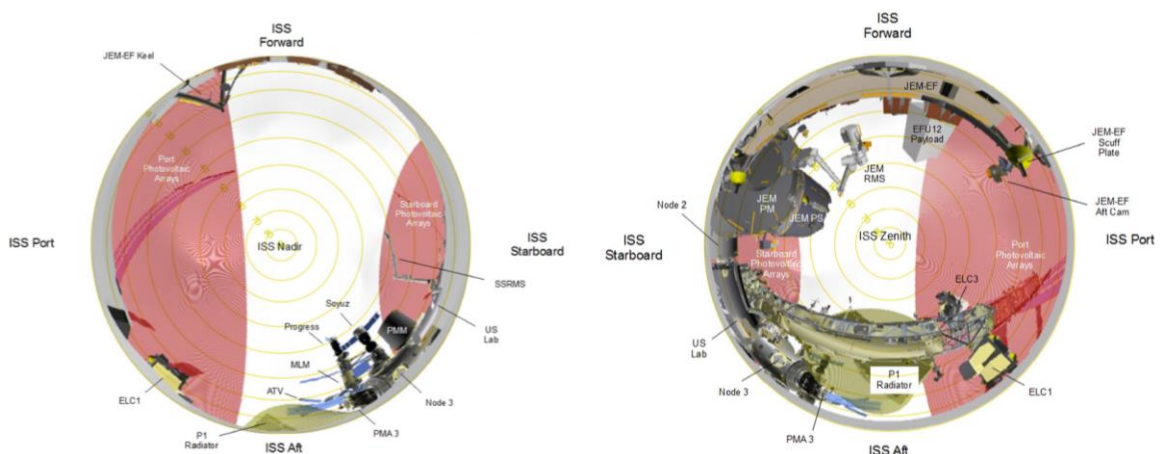
**FIGURE 4.2.7-9 JEM-EF EFU4 PAYLOAD ACCOMMODATION NADIR AND ZENITH**



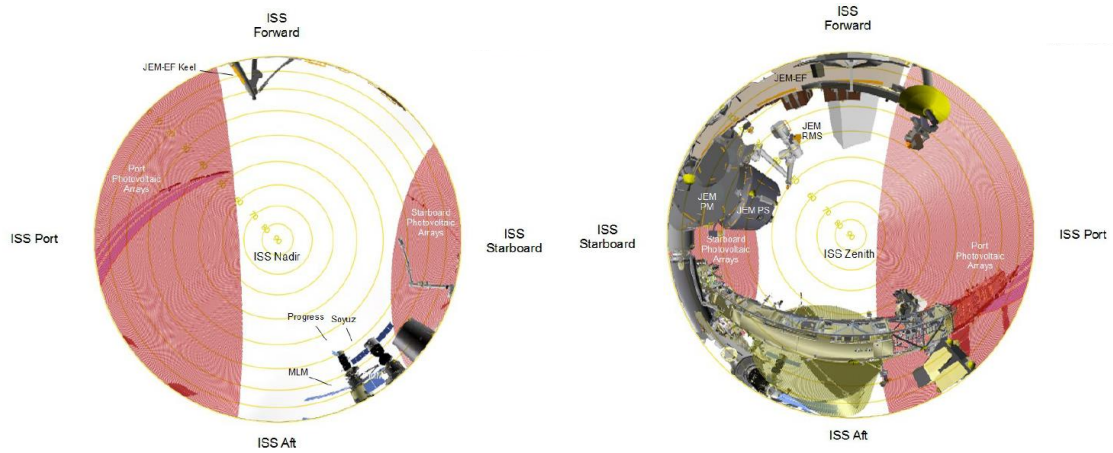
**FIGURE 4.2.7-10 JEM-EF EFU5 PAYLOAD ACCOMMODATION FORWARD (RAM) AND NADIR)**



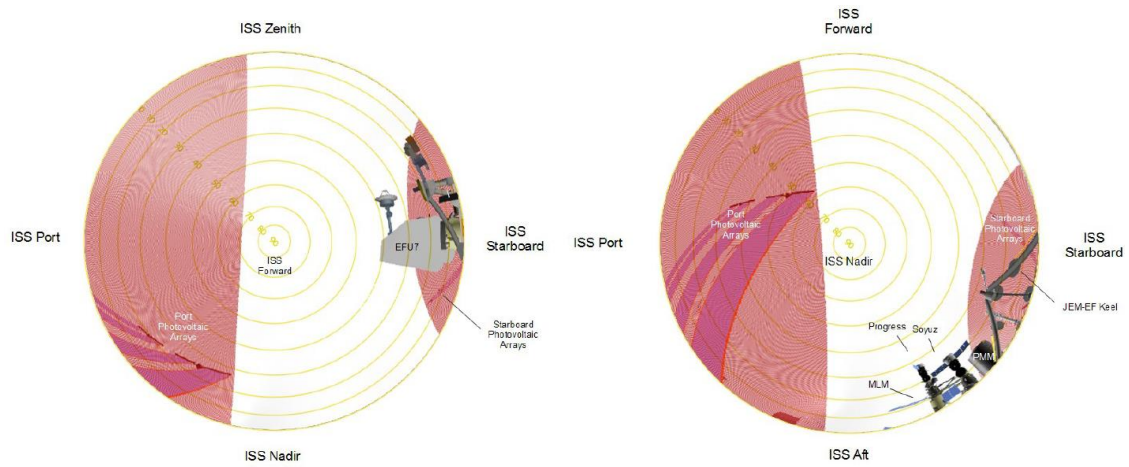
**FIGURE 4.2.7-11 JEM-EF EFU5 PAYLOAD ACCOMMODATION FORWARD ZENITH**



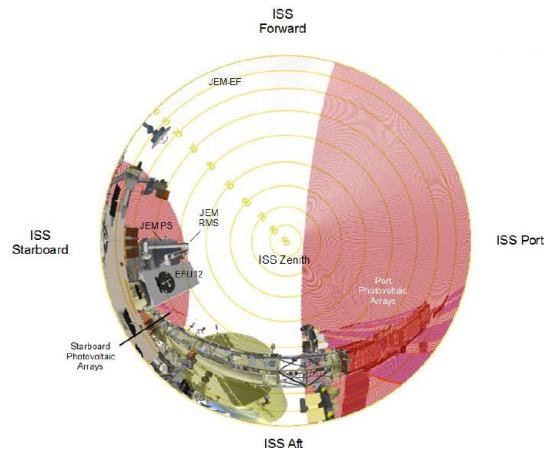
**FIGURE 4.2.7-12 JEM-EF EFU6 PAYLOAD ACCOMMODATION NADIR AND ZENITH**



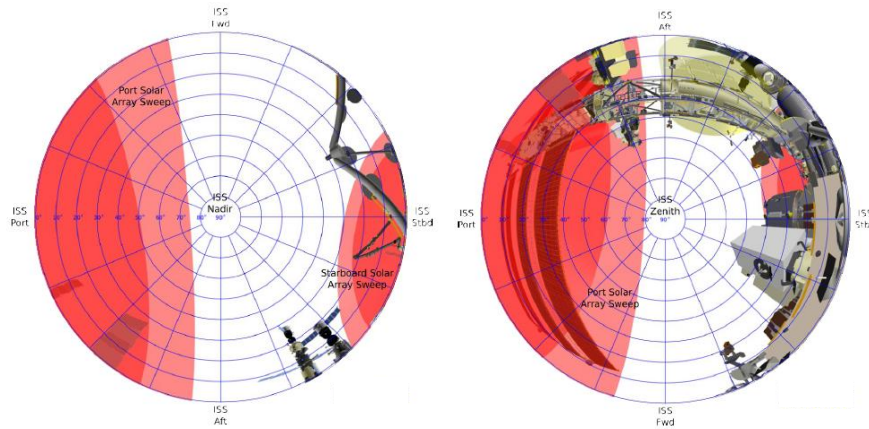
**FIGURE 4.2.7-13 JEM-EF EFU8 PAYLOAD ACCOMMODATION NADIR AND ZENITH**



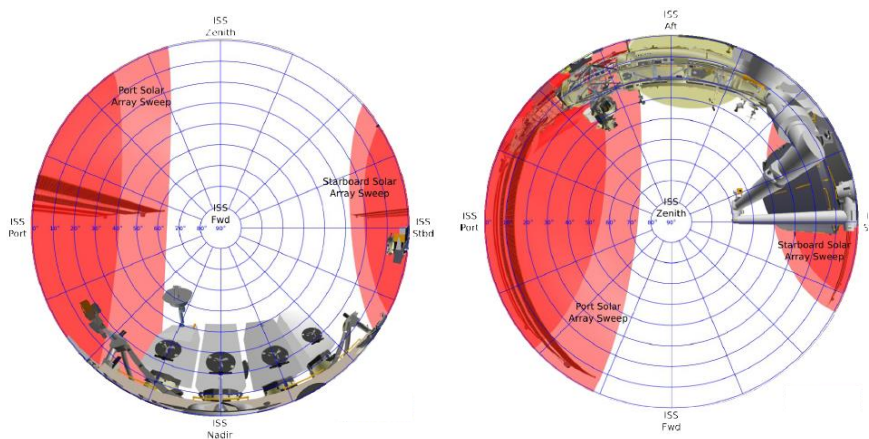
**FIGURE 4.2.7-14 JEM-EF EFU9 PAYLOAD ACCOMMODATION FORWARD (RAM) AND NADIR)**



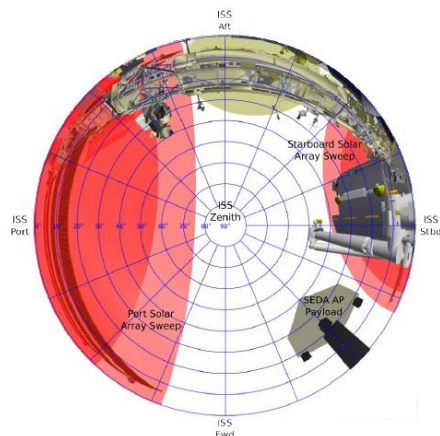
**FIGURE 4.2.7-15 JEM-EF EFU9 PAYLOAD ACCOMMODATION ZENITH**



**FIGURE 4.2.7-16 JEM-EF EFU10 PAYLOAD ACCOMMODATION NADIR AND ZENITH**



**FIGURE 4.2.7-17 JEM-EF EFU11 PAYLOAD ACCOMMODATION FORWARD (RAM) AND ZENITH**



**FIGURE 4.2.7-18 JEM-EF EFU12 PAYLOAD ACCOMMODATION ZENITH**

#### **4.2.8 ELECTROMAGNETIC COMPATIBILITY/ELECTROMAGNETIC INTERFERENCE (EMC/EMI)**

In addition to the information presented in Paragraph 4.1.9, Electromagnetic Compatibility/Electromagnetic Interference (EMC/EMI) of this Guide, PD should be aware that they must also meet the following radiated emissions limit:

- Frequency Range: 23.54 GHz  $\pm$  1 kHz
- Allowable max electrical field density:  $-5.9$  dB  $u$  V/m

Finally, please note that ISS Management Policy Directive (MD-113) applies to all U.S.-funded intentional transmitting and receiving systems for operation on the ISS. This policy provides the authority and requirement to conduct technical reviews in ensuring RF compatibility of the proposed RF system/usage with existing ISS RF operation.

Regarding IP-managed RF payloads for the ISS, the process for coordination of frequency selection and compatibility assurance will be worked through the JSC Spectrum Manager (designated as the ISS Spectrum Manager) as documented in SSP 50423.<sup>39</sup> Additionally, regulatory filing and approval for space operation of an IP-managed RF payloads is the responsibility of the IP, consistent with the applicable domestic regulation and process of the IP. The International filing documentation, at the minimum of API stage, is to be provided to the ISS Spectrum Manager for final validation of ISS onboard compatibility certification. Upon this validation, the payload will be issued an ISS RF Authorization document for Program ICD and IRD requirements closure.

#### **4.3 COLUMBUS EXTERNAL PAYLOAD FACILITY (COLUMBUS-EPF)**

The Columbus-Attached Pressurized Module (APM) is a crew-habitable module attached to the ISS. The location of the APM is illustrated in Figure 4.3-1, Columbus External Payload Sites: SOZ, SOX, SDX, and SDN. The external payload sites are referred to as the EPF.

There are four external payload sites suitable for payloads on the Columbus module, two of which are allocated to NASA at any given time. The four sites are designated SOZ, SOX, SDX, and SDN, where the 'Z', 'X', and 'N' denote zenith, X-axis, and nadir, respectively. These sites are depicted in detail in Figure 4.3-1. Figures 4.3-2a and 4.3-2b, Columbus External Payload Sites, picture the external payload locations. For Earth Science payloads, the sites SDX and SDN, as shown in Figure 4.3-1, are considered optimal. The definitions of the site designations are as follows:

SOZ – Starboard Overhead Zenith; SOX – Starboard Overhead X-Direction; SDX – Starboard Deck X-Direction; and SDN – Starboard Deck Nadir.

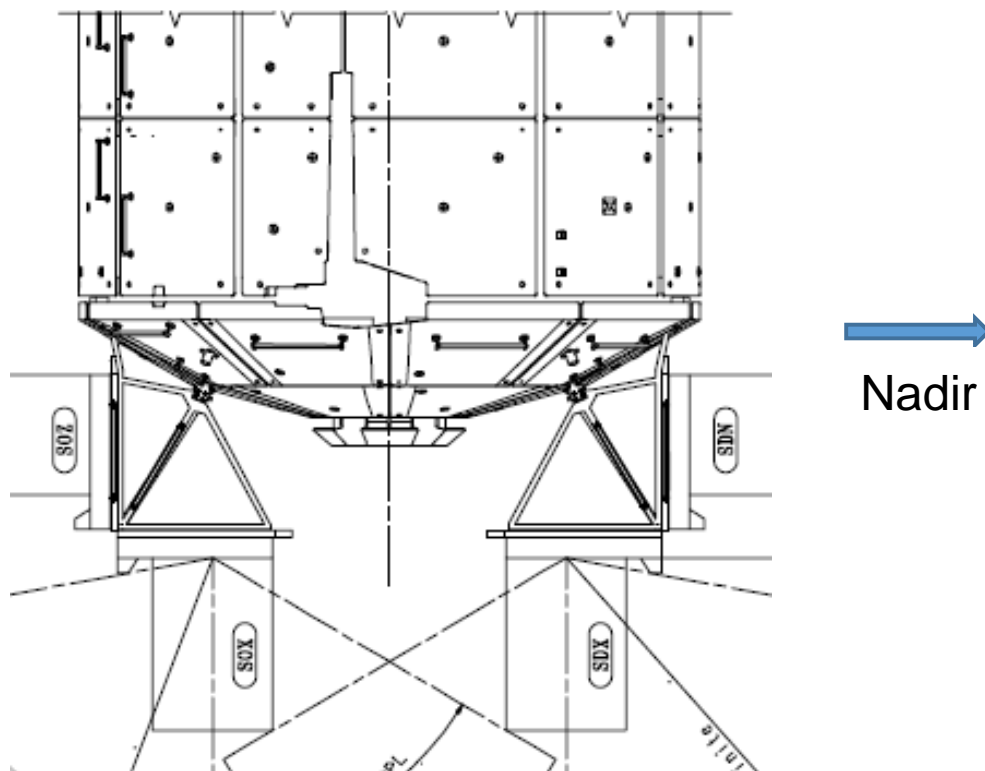
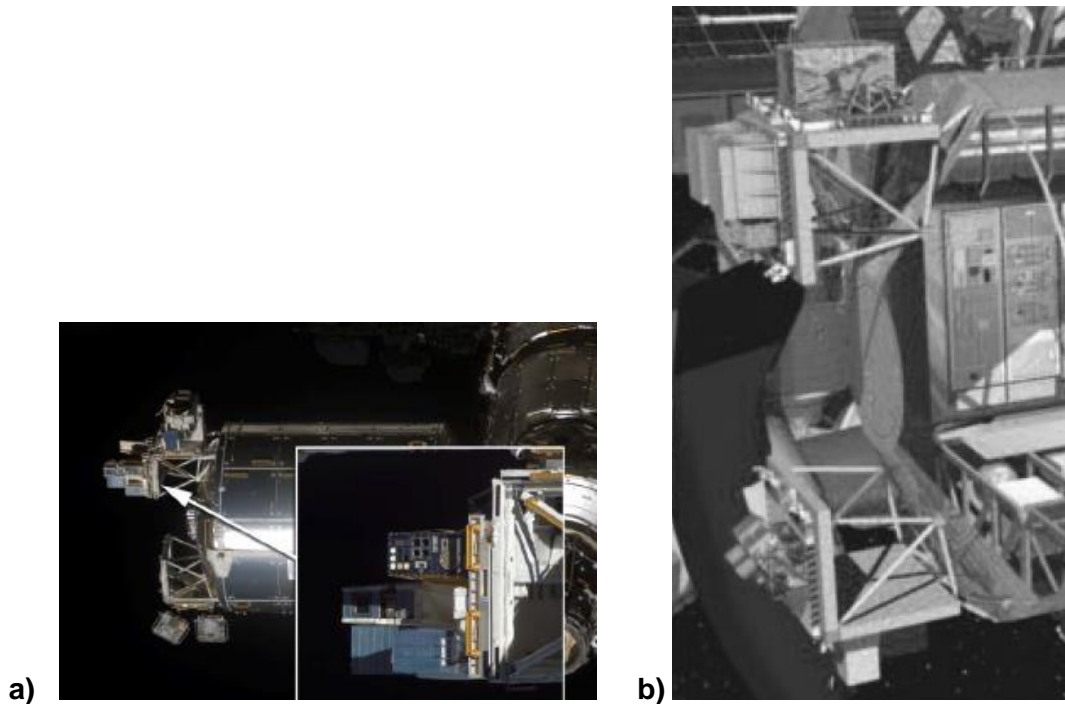
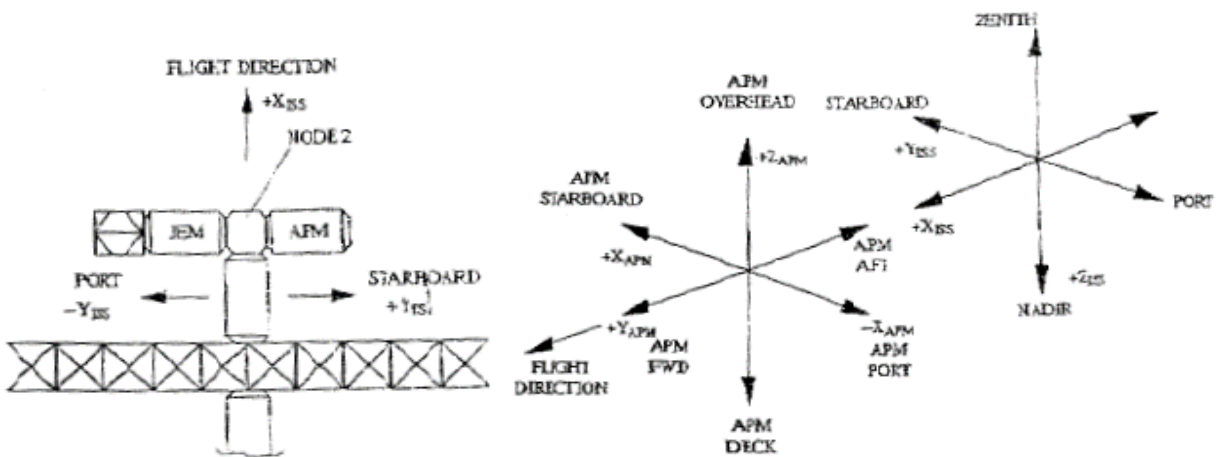


FIGURE 4.3-1 COLUMBUS EXTERNAL PAYLOAD SITES: SOZ, SOX, SDX, AND SDN

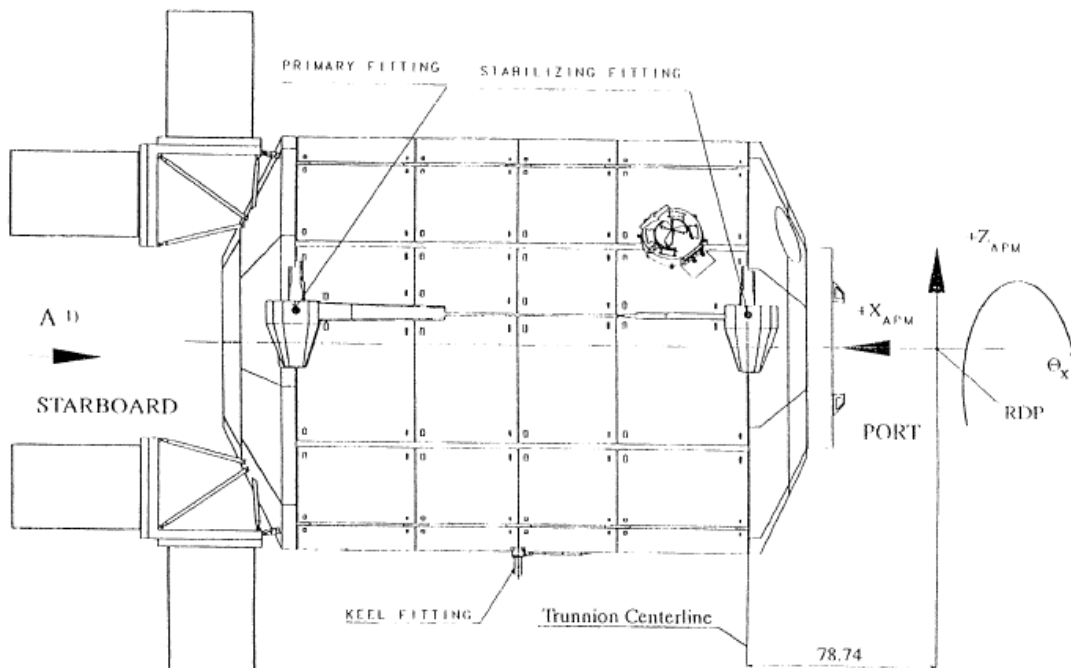


**FIGURE 4.3-2 A AND B COLUMBUS EXTERNAL PAYLOAD SITES**

The Columbus-APM Coordinate System is shown in Figure 4.3-3, APM/ISS Reference Coordinate System and Figure 4.3-4, APM Coordinate System.

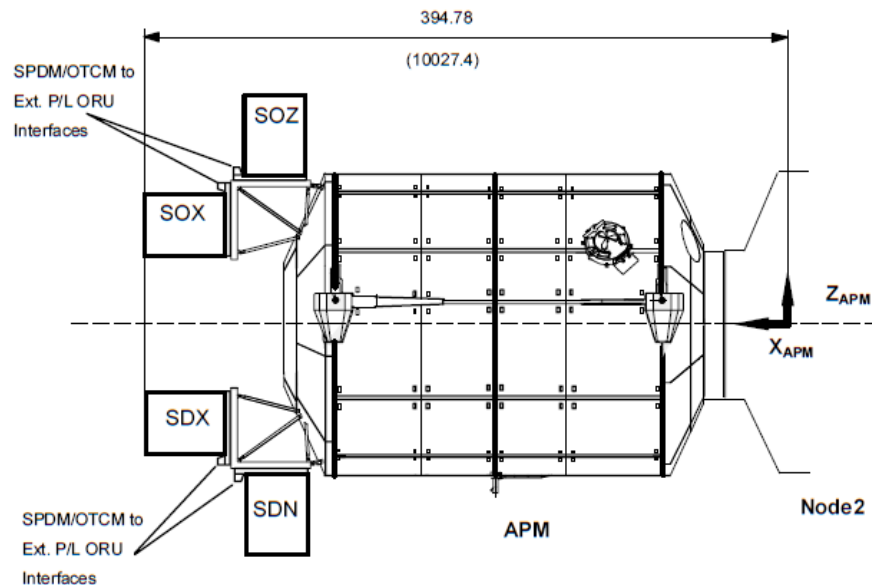


**FIGURE 4.3-3 APM/ISS REFERENCE COORDINATE SYSTEM**



**FIGURE 4.3-4 APM COORDINATE SYSTEM**

Figure 4.3-5, APM with External Payloads and OTCM locations, provides the PD with the external payload locations as they are found on the Columbus-APM. In addition, the OTCM locations are provided, which illustrates the position of the Dextre (SPDM) robotic interfaces. These robotic interfaces are more clearly defined in Paragraph 4.3.2.

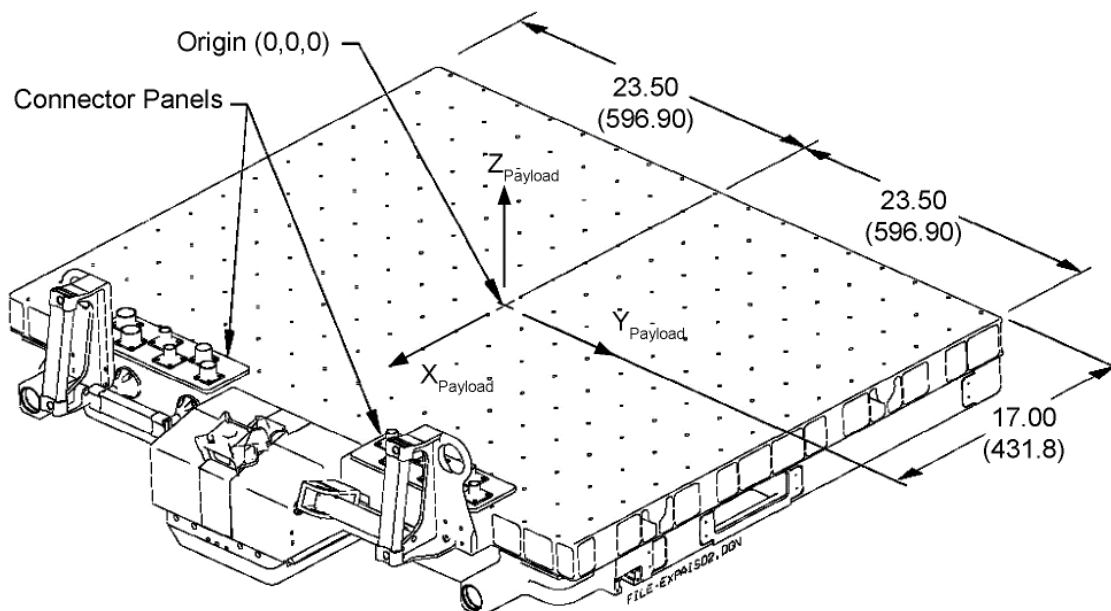


**FIGURE 4.3-5 APM WITH EXTERNAL PAYLOADS AND OTCM LOCATIONS**



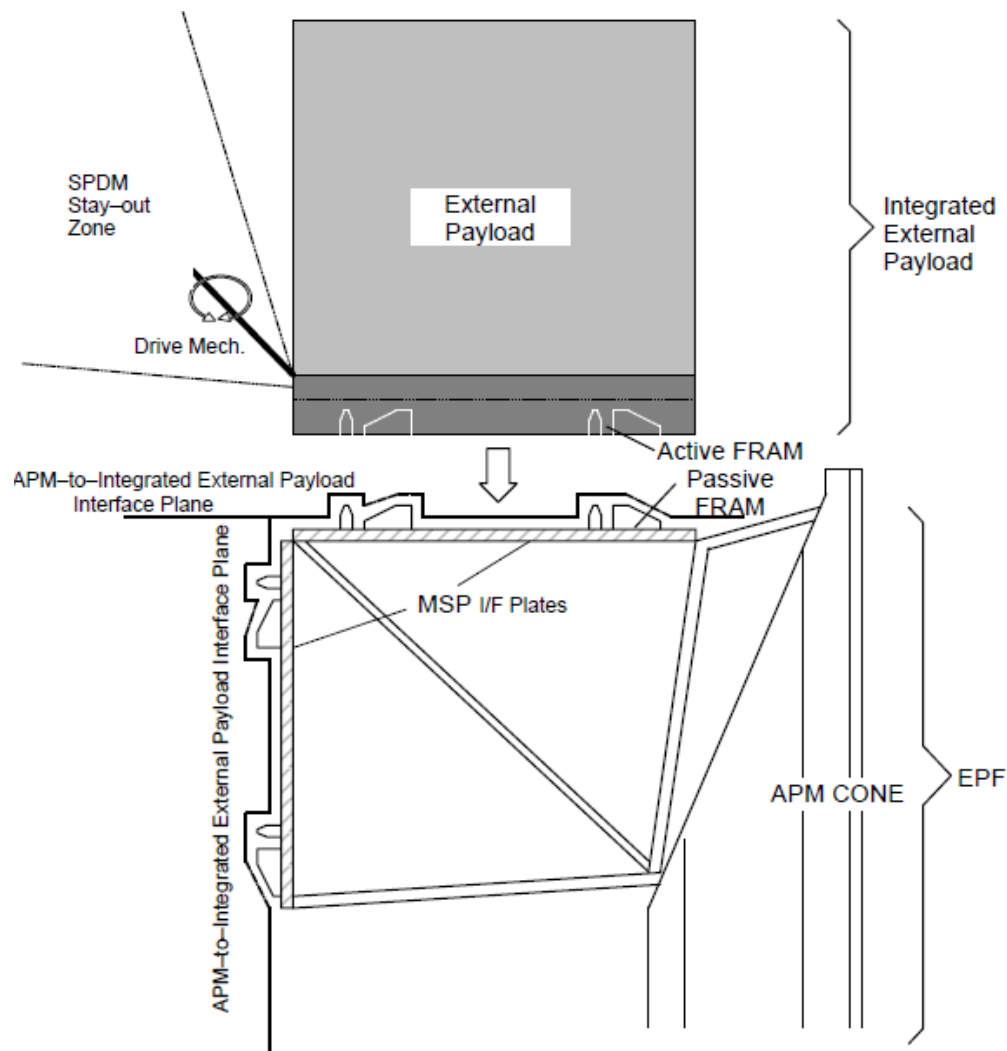
### 4.3.1 PHYSICAL ACCOMMODATIONS

For attachment to the Columbus-EPF, each external payload will be integrated to a Columbus External Payload Adapter (CEPA), similar to the one used on the ELC for the ITA (truss sites), except for the number of power/data connectors. To accommodate a wide variety of payloads, the CEPA assembly provides standard mechanical and electrical/data interface features. In addition, the CEPA assembly provides standardized structural, electrical bonding, and Ground Support Equipment (GSE) interfaces, that are the similar functions provided by the ExPA for the ELC. The CEPA plate configuration provides the required interfaces for integration with the AFRAM. Each AFRAM is a moving mechanical assembly that consists of close tolerance, precision machined components attached to the bottom of an adapter plate. This arrangement is analogous to the ExPA/AFRAM assembly defined for the ELC in Paragraph 4.1. Figure 4.3.1-1, CEPA Isometric View and Coordinate System, provides a CEPA isometric view and coordinate system.



**FIGURE 4.3.1-1 CEPA ISOMETRIC VIEW AND COORDINATE SYSTEM**

The CEPA and AFRAM are compatible with the passive FRAM, which is already contained on the Columbus external payload site. Figure 4.3.1-2, illustrates the mechanical attachment. The CEPA interface contains connectors for the electrical interfaces to the Columbus Module. These interfaces are described in Paragraph 4.3.4. You may also refer to Paragraph 4.1 of the Guide for additional information on the ExPA, including views, configurations, and drawing specifics. The structural attachment interfaces for Columbus payloads are identical to those used by ELC payloads, described in Paragraph 4.1. Please refer to D683-97477-01 Revision D, Columbus External Payload Adapter (CEPA) Assembly Interface Definition Document (IDD),<sup>6</sup> for additional information.



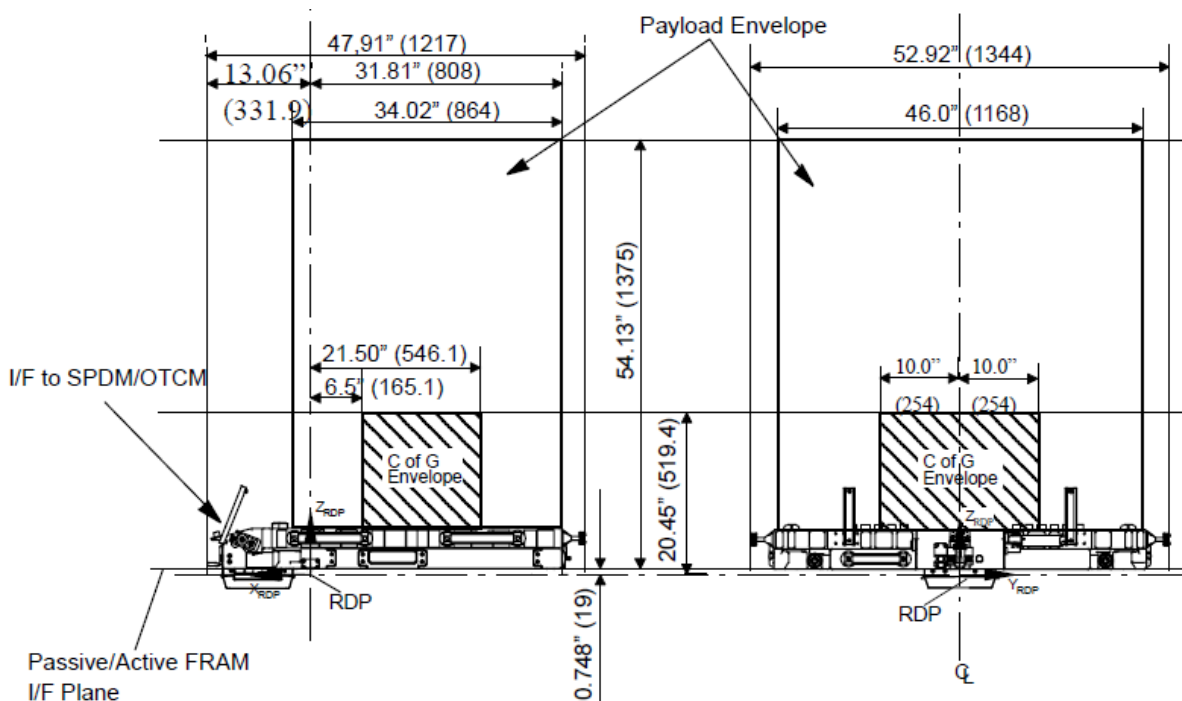
**FIGURE 4.3.1-2 EXTERNAL PAYLOAD TO COLUMBUS ATTACHMENT**

External Payload Mass Allocation

The maximum mass allowed at each External Payload site is 370 kg including the mass of the CEPA and AFRAM. This leaves approximately 230 kg for the payload itself, or roughly 500 lbs, depending on the specific integrated C.G. location for each payload. The proposer should use 500 lbs as their maximum payload weight.

Payload Envelope and C.G. Requirements

The allowable envelope and C.G. for the integrated external payload during on-orbit operation (i.e., after docking to PFRAM) are shown in Figure 4.3.1-3, Integrated External Payload Envelope with a maximum height above the interface plane of  $z = 600$  mm. The maximum payload envelope ( $L \times W \times H$ ) is also shown in Figure 4.3.1-3.



**FIGURE 4.3.1-3 INTEGRATED EXTERNAL PAYLOAD ENVELOPE**

#### 4.3.2 ROBOTICS (SSRMS/SPDM (DEXTRE))

Please review the robotics section contained in Section 3.0, prior to reviewing the specific robotic requirements/accommodations outlined below.

The SSRMS is used in conjunction with the SPDM, or Dextre, to remove a payload from the trunk of a docked visiting vehicle, transfer the payload to the Columbus-APM location, and perform the installation of the payload onto the external payload location.

Dextre can interface directly with a Columbus external payload, by using the attachments contained on the CEPA. The primary purpose of Dextre is to perform dexterous tasks that require fine, minute control. In the past, such tasks have been performed by EVA crewmembers, so being able to perform these tasks with Dextre removes the risk to EVA crewmembers.

The OTCMs attach to specially designed features on the CEPA, and features a retractable, motorized socket wrench used to torque bolts, a retractable umbilical connector used to provide electrical, data, and video connections to payloads, and a camera and lights used for close up viewing and to align the OTCMs with the CEPA-mounted fixtures.

A SpaceX Dragon carrying a Columbus-EPF payload in the Dragon Trunk will be attached at the designated ISS node location. The SSRMs will pick up the Dextre robot, and bring it to near the Dragon. Dextre will reach into the Dragon trunk and an OTCM will engage the fixture on the CEPA (active FRAM portion) of the integrated attached payload. The payload will be released from the Dragon the OTCM driving a bolt with the torque wrench to release the connector and the four clamps, and then Dextre will

remove the payload. After bringing the external payload to the Columbus-APM, it will be installed onto the appropriate external location. After release of the Dragon connector, the payload will have no survival heater power and must be able to survive a minimum of 6 hours without power.

#### 4.3.3 THERMAL

It should be noted that the Columbus external payload sites do not provide active thermal control interfaces, thus the external attached payload will need to be compliant with the following section. The External Payload Site Temperature range with no Payload attached (EPF/PFRAM) will be between  $-72\text{ }^{\circ}\text{C}$  to  $+48\text{ }^{\circ}\text{C}$ . The mechanical functionality of the active and PFRAM design (see Paragraph 4.3.1 for interface plane definition) during berthing and un-berthing will be assured if the PD plans for thermally conditioning the integrated external payload to a temperature range between  $-21\text{ }^{\circ}\text{C}$  ( $-5.8\text{ }^{\circ}\text{F}$ ) to  $+49\text{ }^{\circ}\text{C}$  ( $+120.2\text{ }^{\circ}\text{F}$ ). For analytical integration purposes, the payload should not rely on conductive heat exchange across the integrated payload to EPF interface.

The reflected incident solar and incident infrared (heat) radiation from the integrated external payload onto the surfaces of other on-orbit segments cannot exceed  $30\text{ W/m}^2$ , average on the EPF as a whole and  $60\text{ W/m}^2$ , locally on the EPF, as calculated over the individual area of each node belonging to the ISS TMM for external payload mounted on the Columbus External Payload Facility (CEPF).<sup>48</sup> Peak values during on orbit must not exceed twice the above values for both incident solar energy and heat radiation.

The proposer of an integrated external payload will need to consider their payload being exposed to and must be compatible with the thermal solar constants, albedo and Earth OLR environments as defined for all operational modes in Tables 4.3.3-1, Thermal Environment Parameters and 4.3.3-2, ISS Flight Attitudes.

The proposer should consider induced thermal environments for the integrated external payload. It will be exposed to and must be compatible with the induced thermal environments from vehicle(s) docking and docked with the ISS, and thermal interactions with other on-orbit segments. The analysis of the induced thermal effects on the integrated external payload should be based on the beta angle extremes, orbital altitude, and altitude variation about the ISS vehicle axes are provided in Table 4.3.3-2.

For reference of the thermal interface to the ISS and the EPF, the proposer can use the induced thermal environment determined based on the model definitions in:

- D684-10058-03-02, Integrated ISS Thermal Math Models, Volume 3 Book 2, International Space Station Program, Boeing/ NASA, JSC (R.D. 2.2.9)<sup>8</sup>
- CLT-TN-AI-0038, Issue 6, 24.05.2005 (R.D. 2.2.10), APM Simplified Thermal Mathematical Model Description for ISSA/APM/I/F Thermal Analysis,<sup>10</sup>

The corresponding definition of the overall thermal interface model is provided in:

ISS TMM for External payload mounted on the CEPF,<sup>48</sup> TEC-MCV/2005/3075/In/HFLR,<sup>50</sup> (A.D. 2.1.42). A.D. 2.1.42 should be used for thermal modeling of the integrated external payload induced thermal environment.

### Thermal Models

Key thermal considerations that must be addressed by the external PD are the development and delivery of a thermal model in required format and generation of thermal analyses to demonstrate that the payload will remain safe during LTA, as well as applicable on-orbit stowage sites on the ISS. These models will be provided to support required thermal assessment by the launch vehicle integrator and the ISS vehicle integrator.

The external PD will be required to develop and deliver a thermal model compatible with Thermal Desktop® and TRASYS/SINDA. The model is expected to be comprised of no more than 500 geometric and 500 mathematical nodes that represent all geometric and material properties required for determining critical hardware temperatures. These models will be utilized by the PD to assess the external payload in its on-orbit configuration, including the time periods while stowed in the launch vehicle and on the ISS Columbus-EPF. These models will be provided to the ISS Program in order to support required thermal assessments by the launch vehicle integrator and the ISS vehicle integrator.

### Thermal Analysis

The external attached payload must remain safe during the LTA phase while stowed in the launch vehicle, as well as, during the subsequent phase while it is stowed on an ISS Columbus-EPF when it is exposed to a space sink temperature of 3 K, the thermal environment parameters defined in Table 4.3.3-1, the ISS flight attitudes and solar beta angle ranges defined in Table 4.3.3-2 (similar attitude requirements will be defined for the applicable launch vehicle) and the thermal interactions with all other on-orbit hardware. Verification of safe operation will require PD generated thermal analysis using ISS Program provided launch vehicle and ISS thermal models integrated with a PD developed thermal model of the proposed payload.

**TABLE 4.3.3-1 THERMAL ENVIRONMENT PARAMETERS**

Case	Solar Constant (W/m <sup>2</sup> )	Earth Albedo	Earth OLR (W/m <sup>2</sup> )	Altitude (km)
Cold	1321	0.2	206	500
Hot	1423	0.4	286	278

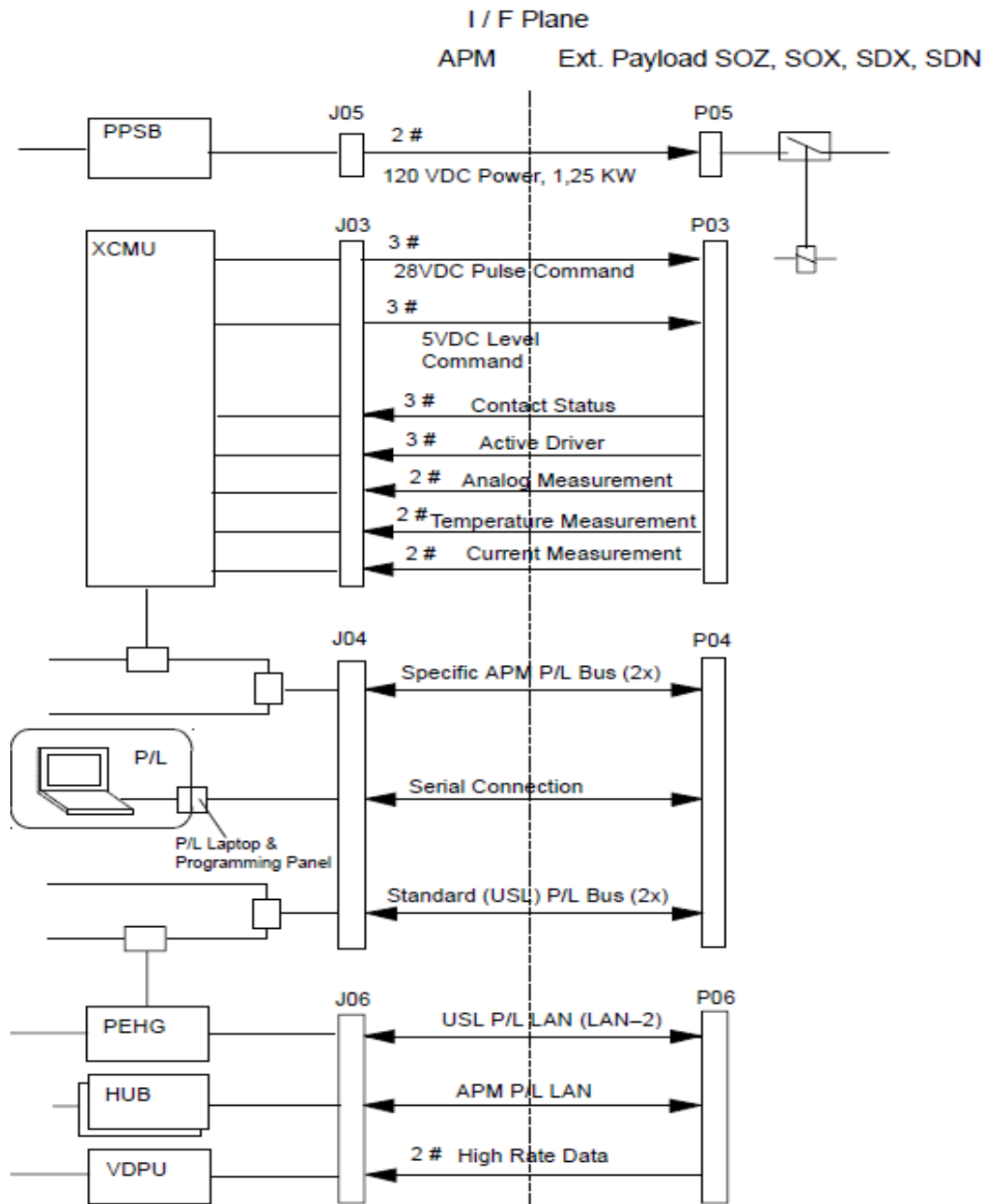
**TABLE 4.3.3-2 ISS FLIGHT ATTITUDES**

ISS Attitude Name	Attitude Reference Frame	Solar Beta Range ( $\beta$ )	Yaw	Pitch	Roll	Time in Attitude
+XVV +Z Nadir	LVLH	$-75^\circ \leq \beta \leq +75^\circ$	$-15^\circ$ to $+15^\circ$	$-20^\circ$ to $+15^\circ$	$-15^\circ$ to $+15^\circ$	No Limit
-XVV +Z Nadir	LVLH	$-75^\circ \leq \beta \leq +75^\circ$	$+165^\circ$ to $+195^\circ$	$-20^\circ$ to $+15^\circ$	$-15^\circ$ to $+15^\circ$	No Limit
+YVV +Z Nadir	LVLH	$-75^\circ \leq \beta \leq +10^\circ$	$-110^\circ$ to $-80^\circ$	$-20^\circ$ to $+15^\circ$	$-15^\circ$ to $+15^\circ$	No Limit
-YVV +Z Nadir	LVLH	$-10^\circ \leq \beta \leq +75^\circ$	$+75^\circ$ to $+105^\circ$	$-20^\circ$ to $+15^\circ$	$-15^\circ$ to $+15^\circ$	No Limit
+ZVV -X Nadir	LVLH	$-75^\circ \leq \beta \leq +75^\circ$	$-15^\circ$ to $+15^\circ$	$+75^\circ$ to $+105^\circ$	$-15^\circ$ to $+15^\circ$	3 Hours
-ZVV -X Nadir	LVLH	$-75^\circ \leq \beta \leq +75^\circ$	$+165^\circ$ to $+195^\circ$	$+75^\circ$ to $+105^\circ$	$-15^\circ$ to $+15^\circ$	3 Hours

#### 4.3.4 POWER (AND ELECTRICAL INTERFACES)

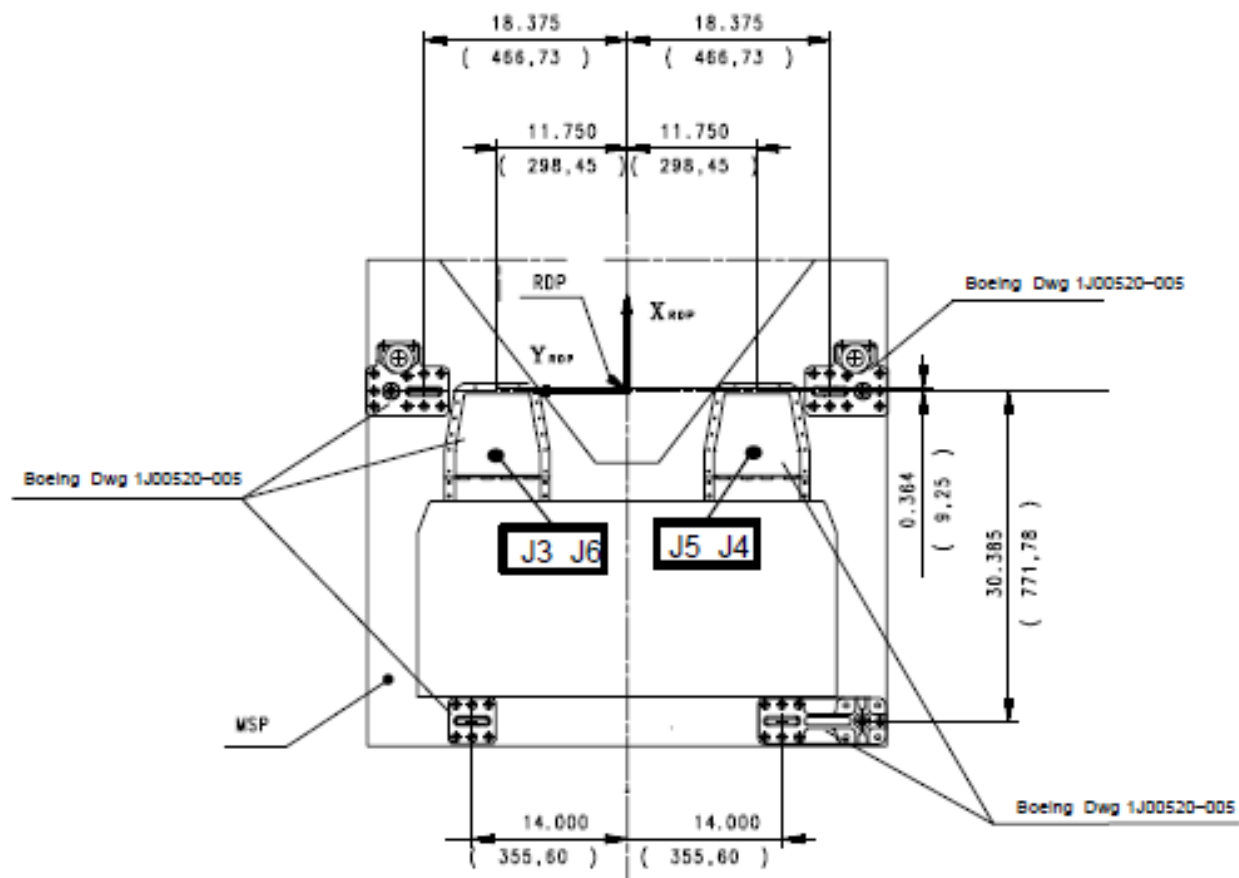
##### Electrical Interfaces

The external payload electrical specific system interfaces are contained in Figure 4.3.4-1, Integrated External Payload System Interfaces.



**FIGURE 4.3.4-1 INTEGRATED EXTERNAL PAYLOAD SYSTEM INTERFACES**

These system interfaces are accommodated by four electrical connectors built into the CEPA shown in Figure 4.3.4-2, Electrical Connectors.



- Notes:
- 1) Interface treatment: Alodine acc. to MIL-C-5541 Class III
  - 2) Bonding: metal to metal

**FIGURE 4.3.4-2 ELECTRICAL CONNECTORS**

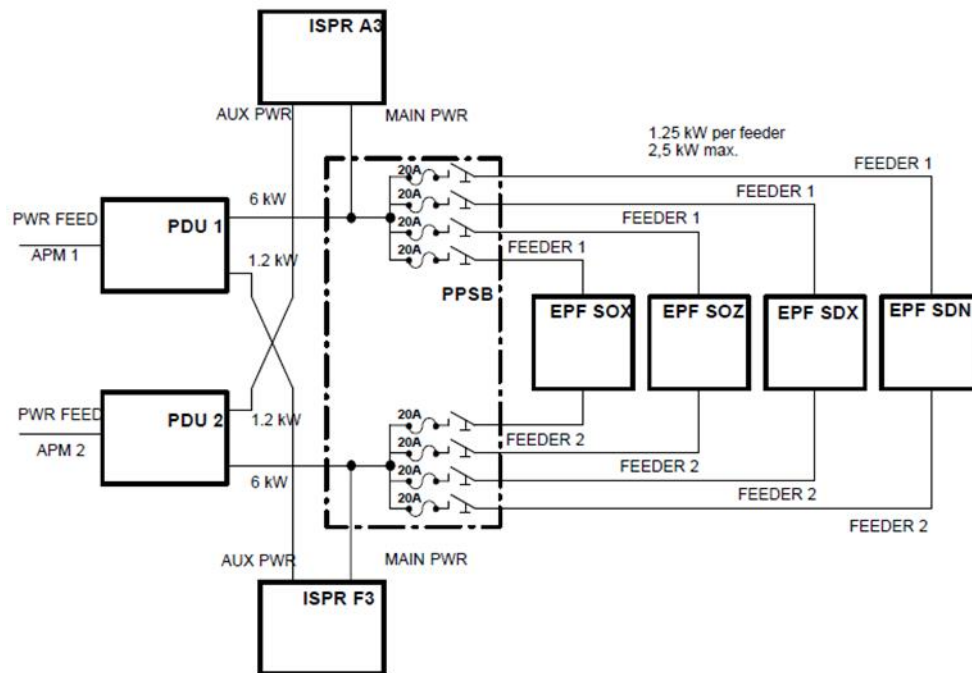
Power

The EPF external attached payloads are provided power (via the electrical connectors, J05/P05) as illustrated in Figure 4.3.4-3, External Payload Power Distribution. Each external payload site is provided two power feeds, Feeder 1 and Feeder 2. Each feed is 1.25 kW with a maximum limit of 2.5 kW. The nominal steady-state voltage range at the external payload interface is 120 Vdc, and ranges from 113 Vdc to 126 Vdc. There are certain limitations and caveats associated with the use of these power feeds. These limitations can be found in the, COL-RIBRE-SPE-0165, Paragraph 3.2, COLUMBUS External Payloads Interface Requirements Document.<sup>4</sup> The referenced section also provides additional detailed information on electrical power characteristics and cable, wire, and connector design requirements.

NOTE: Columbus-supplied power is a shared resource among the Columbus payload complement. The actual power allocated by the ISS Program will be less than that



listed as maximums contained within in this section. Contact the ISS RIO for additional information.



**FIGURE 4.3.4-3 EXTERNAL PAYLOAD POWER DISTRIBUTION**

### Loss of Power

In the event of a total or partial loss of power, regardless of the availability of the second (redundant) power feeder, the integrated external payload should fail safe in accordance with SSP 51700, Payload Safety Policy and Requirements for the International Space Station.<sup>41</sup>

### Inadvertent Power On/Off Sequence

In the event of an inadvertent APM Power Drive Unit International Standard Payload Rack (ISPR) outlet power ON/power OFF sequence, the integrated external payload should remain in a safe condition.

### **4.3.5 COMMAND AND DATA HANDLING (C&DH)**

For each Columbus external payload there are several data interface options available, which are described below. The C&DH interfaces are provided via connectors J3/P3, J4/P4, and J6/P6 (reference Figure 4.3.4-2). The interfaces include a MIL-STD-1553B<sup>14</sup> data bus, Ethernet, high-rate data, and analog and digital (discrete) signals. The specifics of these interfaces are described in the following paragraphs. Detailed C&DH interface characteristics and requirements can be found in the COL-RIBRE-SPE-0165, Paragraph 3.3, COLUMBUS External Payloads Interface Requirements Document,<sup>4</sup>

### Low-Rate Data Link

An extension of the U.S. payload MIL-STD-1553B<sup>14</sup> (20 kbps typical telemetry throughput) data bus will be used for low-rate data transfer, e.g., commanding, time and ancillary data broadcast, file transfer, payload health and status, and payload science data, if chosen. The payload will operate as a RT, and up to 2 U.S. payload RTs are supported. Refer to COL-RIBRE-SPE-0165, Columbus External Payloads IRD, Paragraph 3.3.4.<sup>4</sup>

### Medium Rate Data Link (Wireless)

A MRDL path using a wireless Ethernet data link is available for Columbus-EPF payloads. It consists of a two-way high data rate communications link using RFs per IEEE 802.11n. This EWC system provides two-way data transfer between the payload sites and the PEHG in the USL. Data rates available to the payload are dependent upon the specific Columbus-EPF location. Average payload user data rates of 3 Mbps are easily supportable; higher data rates are possible but require coordination with other payloads.

(Although NASA has completed a preliminary coverage map for the EWC System, this information is not included as assumptions made in generating the coverage map may not apply to the Columbus-EPF external payload utilizing the EWC. External payloads that will utilize the EWC should coordinate with NASA to obtain coverage information. The EWC user should refer to D684-14957-01, International Space Station (ISS) ELC Wireless Comm (EWC) User Guide,<sup>9</sup> for additional information).

### Medium Rate Data Link (Wired)

This interface is part of the MRDL Ethernet 10/100 Base T network. Downlink via the PEHG gateway per SSP 52050 Rev. K, Paragraph 3.3.5.1,<sup>42</sup> is dedicated to U.S. payloads.

### High-Rate Data Link (HRDL)

This one-way high-rate data transmission path operates at an encoded signaling rate of 100 Mbps. It uses the protocol and data rates up to a limit of 32 Mbps can be achieved by parsing the data with sync symbols. Details of this interface are in Paragraph 3.3.6 of the COL-RIBRE-SPE-0165.<sup>4</sup>

### External Command and Monitoring Unit (XCMU) Interfaces

Each EPF payload site is provided from the Columbus Data Management System (DMS) with three contact status inputs, three active driver status inputs, two analog signal inputs, two current measurement inputs, two temperature sensor inputs, three 5 V level commands, and six 28 V pulse commands. NASA payloads may use these interfaces. Detailed interface characteristics may be found in COL-RIBRE-SPE-0165, Paragraph 3.3.7.<sup>4</sup>

Serial Interfaces

The Columbus module provides for each EPF location a 4-wire communication link. This link may be used by the external payload to transmit serial commands and data between a module internal Laptop and the external payload control computer for reprogramming purposes. The payload must supply the Laptop.

**4.3.6 WIRELESS CAPABILITY**

Refer to Paragraph 3.1.2 for wireless capabilities.

**4.3.7 FIELDS OF VIEW (FOV)**

The following provides the proposer a series of fish-eye images of the FOV from those Columbus-EPF ExPA/FRAM locations available to hosted NASA external payloads, reference Figure 4.3.7-1, Columbus-EPF Overview. For each payload location, a generic payload volume measuring 46 x 34 x 49 inches was used, see Figure 4.3.7-2, Columbus-EPF Payload Dimensions. For each payload volume, the 46-inch dimension runs from ISS Forward to ISS Aft. The 49-inch dimension is the height of the payload measure from, and normal to each EPF FRAM mounting surface. The viewpoint location for these images was the center of each payload face normal to the view direction. These images were generated by the MAGIK Team software tools, at ISS/JSC (see Figures 4.3.7-3 through 4.3.7-6). The solid objects in the FOV remain there at all times while the pink shaded areas in the FOV represent the areas swept by the ISS solar (photovoltaic) arrays as they track the sun. A summary of these fish-eye FOV images is provided in Table 4.3.7-1, Index of Columbus-EPF Fish-Eye FOV Images.

**TABLE 4.3.7-1 INDEX OF COLUMBUS-EPF FISH-EYE FOV IMAGES**

Carrier	Location	Optimum Viewing Directions	ISS Aft FOV	ISS Forward FOV	ISS Nadir FOV	ISS Zenith FOV
Columbus	SDN	Ram/Nadir		✓	✓	
Columbus	SDX	Ram/Nadir		✓	✓	
Columbus	SOX	Ram/Zenith		✓		✓
Columbus	SOZ	Ram/Zenith		✓		✓

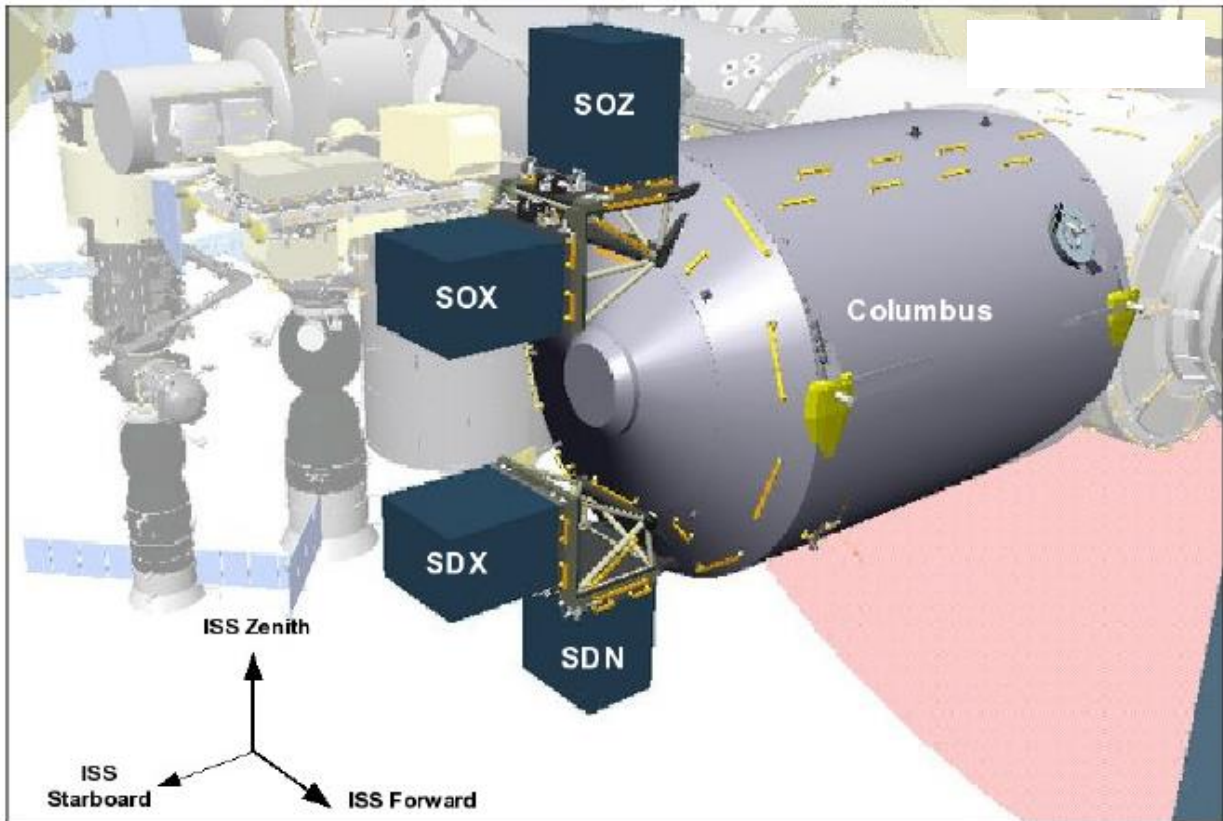


FIGURE 4.3.7-1 COLUMBUS-EPF OVERVIEW

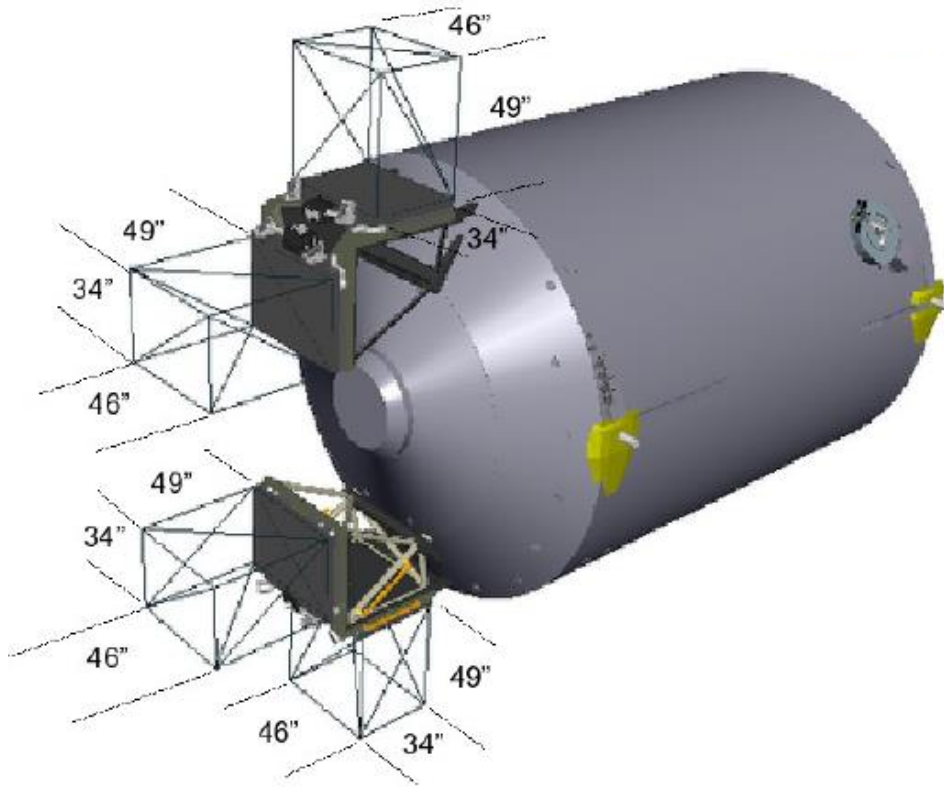


FIGURE 4.3.7-2 COLUMBUS-EPF PAYLOAD DIMENSIONS

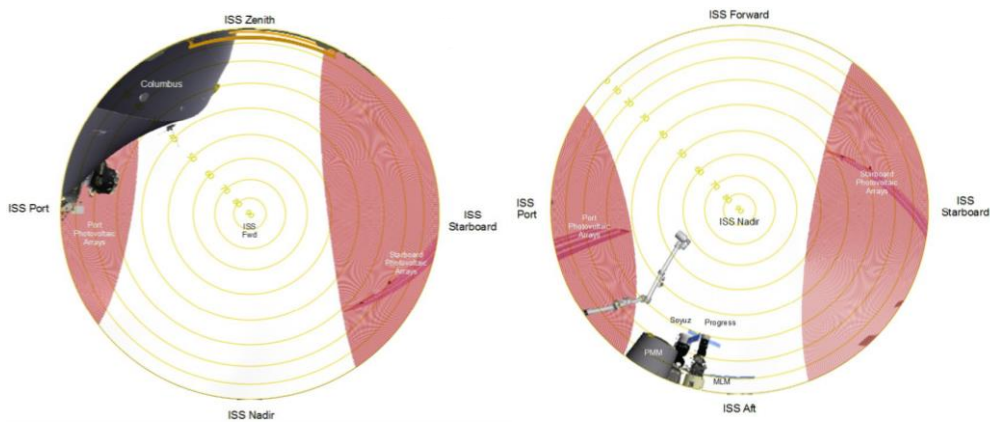
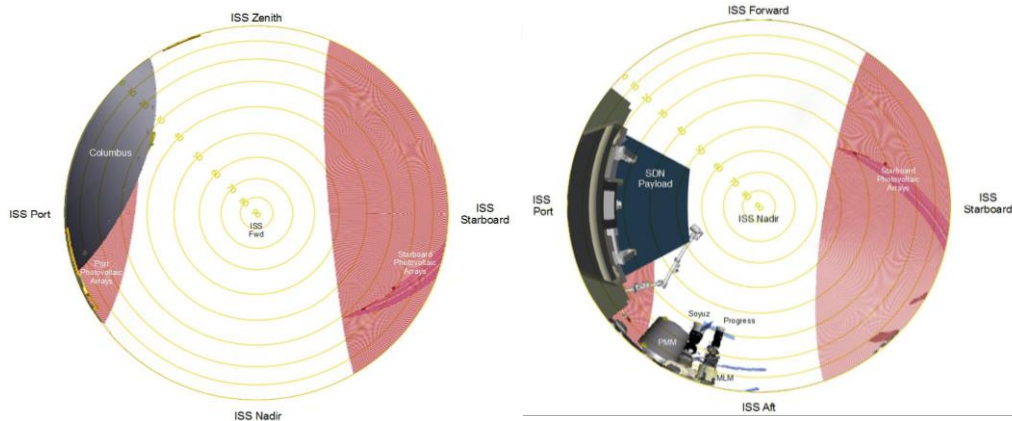
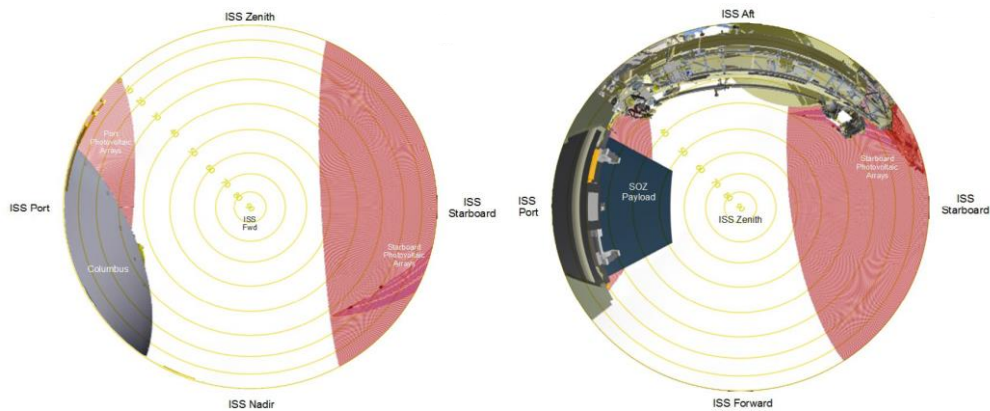


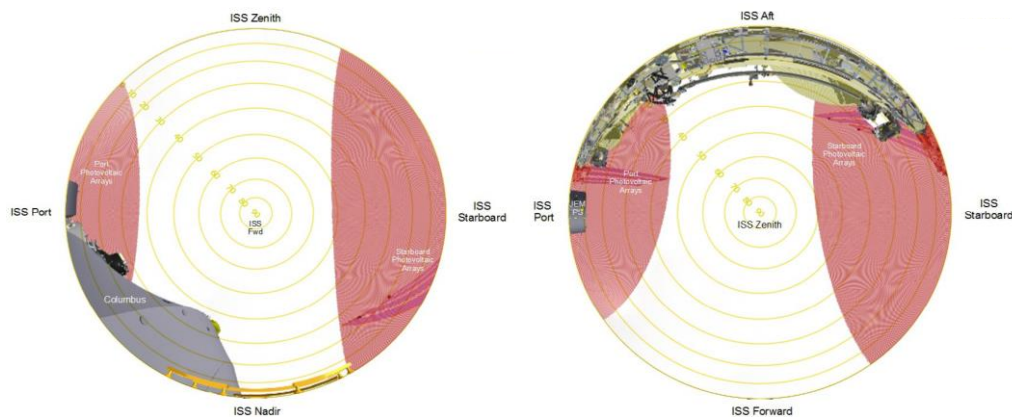
FIGURE 4.3.7-3 COLUMBUS SDN EXPA PAYLOAD ACCOMMODATION FORWARD (RAM) AND NADIR



**FIGURE 4.3.7-4 COLUMBUS SDX EXPA PAYLOAD ACCOMMODATION FORWARD (RAM) AND NADIR**



**FIGURE 4.3.7-5 COLUMBUS SOX EXPA PAYLOAD ACCOMMODATION FORWARD (RAM) AND ZENITH**



**FIGURE 4.3.7-6 COLUMBUS SOZ EXPA PAYLOAD ACCOMMODATION FORWARD (RAM) AND ZENITH**

#### **4.3.8 ELECTROMAGNETIC COMPATIBILITY/ELECTROMAGNETIC INTERFERENCE (EMC/EMI)**

In addition to the information presented in paragraph 3.1.8, the PD should be aware that ESA EMC/EMI requirements are contained in the COL-RIBRE-SPE-0165.<sup>4</sup>

By agreement between NASA and ESA, a payload can show compliance to either the EMI requirements of COL-RIBRE-SPE-0165<sup>4</sup> or SSP 30237.<sup>26</sup>

Finally, it should be noted that ISS Program Management Directive, ISSP-MD-113, applies to all U.S.-funded intentional transmitting and receiving systems for operation on the ISS. This policy provides the authority and requirement to conduct technical reviews in ensuring RF compatibility of the proposed RF system/usage with existing ISS RF operation.

Regarding IP-managed RF payloads for the ISS, the process for coordination of frequency selection and compatibility assurance will be worked through the JSC Spectrum Manager (designated as the ISS Spectrum Manager) as documented in SSP 50423.<sup>39</sup> Additionally, regulatory filing and approval for space operation of an IP-managed RF payloads is the responsibility of the IP, consistent with the applicable domestic regulation and process of the IP. The International filing documentation, at the minimum of API stage, is to be provided to the ISS Spectrum Manager for final validation of ISS onboard compatibility certification. Upon this validation, the payload will be issued an ISS RF Authorization document for Program ICD and IRD requirements closure.

## 5.0 INTEGRATION AND OPERATIONS

The integration and operation of external payloads on the ISS is a vital area that must be evaluated thoroughly by the proposer. Paragraph 5.1, Integration, contains an overview of the integration template, engineering and physical integration processes, and Paragraph 5.2, ISS Operations outlines the operations process. In addition, the safety process is contained in Section 7.0, Flight and Ground Safety Process of the Guide.

The engineering integration and operations areas, for both the ISS and launch vehicle/visiting vehicle, is often underestimated by proposers, but will require a substantial amount of effort during the implementation phase of payload development, and will require a substantial amount of resources. ISS document OZ-10-056, Payload Developers and Principal Investigators Payload Planning, Integration and Operations Primer,<sup>23</sup> is an excellent source for in-depth understanding of the manifesting, integration, and operations processes for the ISS.

### 5.1 INTEGRATION

#### 5.1.1 INTEGRATION TEMPLATE (REFERENCE MILESTONES)

An overview of the ISS critical integration milestones, along with ancillary data, is shown in Figure 5.1.1-1, ISS Integration Template. It is NOT the intent of this Guide to provide detailed explanations of each milestone contained in the Template, nor do you have to familiarize yourself with every nuance contained in the Template. However, it has been incorporated so the proposer may adequately assess the number of data submittals, activities, reviews, and corresponding tasks associated with this critical process, as described in Figure 5.1.1-1.

The documents listed in this section will prove crucial to the successful integration of your payload onto the ISS. However, it is the responsibility of the PD to design the payload to conform to the appropriate set of interface requirements specified by the ISS Program.

As indicated on the integration template, the PD will be responsible for developing numerous data inputs. For example, inputs are required from the PD the Integrated PDR and Integrated Critical Design Review (CDR), which require significant resources.

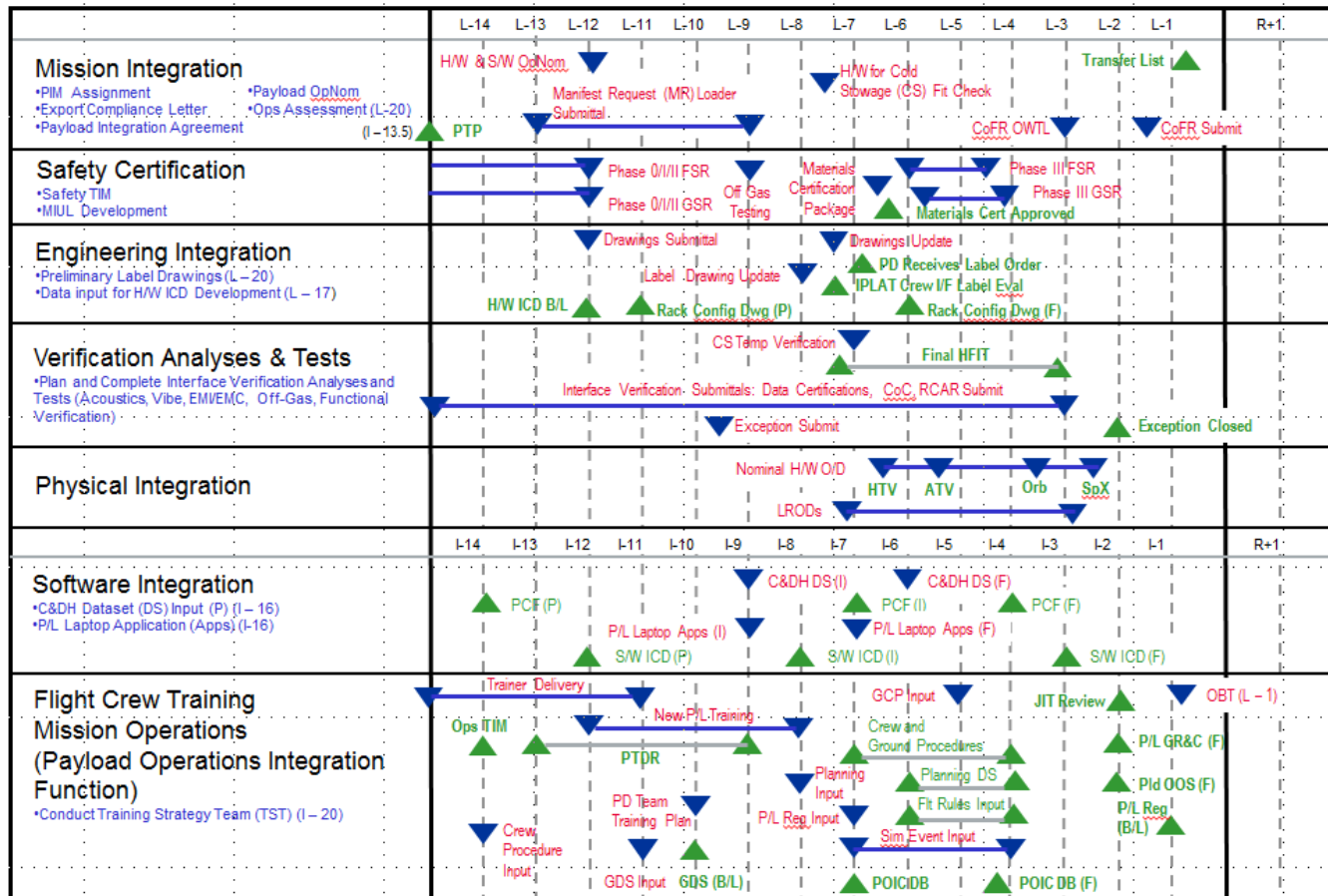
The PIM initializes customer interfacing and the development of a specific Payload Integration Agreement (SSP 57061, Standard Payload Integration Agreement for Attached Payloads),<sup>50</sup> the payload-unique ICD, a tailored schedule of specific events for your payload, and delivery of payload data products that will be used for safety and verification for flight on the ISS.

#### Integration Template

The Payload Integration Template, as defined, involves the integration of a payload with both the ISS vehicle and ground operations. The template is a flight (or increment) driven template in that a payload is assigned a flight on an increment and the PD works



the associated milestones to meet that flight/increment's template. Additional template information can be found in SSP 57004-ELC.<sup>46</sup>



▼ Payload Milestone      ▲ Payload Integration Team Milestone      Reference: SSP 57057 – Payload Integration Template

FIGURE 5.1.1-1 ISS INTEGRATION TEMPLATE

## 5.1.2 ENGINEERING INTEGRATION (EI) PROCESS

This section primarily outlines the ISS engineering integration process. The integration process of each launch vehicle/visiting vehicle is somewhat dependent on which vehicle is eventually selected, so the launch vehicle/visiting vehicle section of the Guide, Section 6.0, Launch Vehicles and Visiting Vehicles Supporting ISS External Payloads provides a summary of a specific launch vehicle integration process for the existing launch vehicle. Finally, the physical integration, while not specifically part of the EI process, is briefly covered in the last portion of Paragraph 5.1.

### 5.1.2.1 ISS INTERFACE REQUIREMENTS (ITA USING THE ELC)

The SSP 57003-ELC, Attached Payload Interface Requirements Document (IRD)-ExPRESS Logistics Carrier,<sup>44</sup> is the principle source of interface design requirements for attached payloads flying on the ELC (ITA sites). In order for an external payload to be certified for integration into the ISS external sites, there must be compliance with the IRD.

The IRD levies design interface and verification requirements on ISS external payloads. These requirements are allocated to an external payload payload through the applicability matrix in the unique payload ICD. The unique payload ICD defines and controls the design of the interfaces between the ISS and the payload, including unique interfaces. Therefore, for external payloads flying on the ELC, the applicable ISS interface requirements document is the SSP 57003-ELC IRD.<sup>44</sup> All requirements defined in the IRD, including physical, functional, and environmental design, and interface compatibility, apply to on-orbit phases of operation. On-orbit requirements apply to all external payloads of the ISS located and mounted on the ITA. Examples of interface requirements elements contained in the SSP 57003-ELC IRD<sup>44</sup> are:

- Structural/Mechanical and Microgravity
- Electrical
- C&DH
- Passive Thermal Control
- Environment
- Materials and Parts
- EVR
- Maintainability and Maintenance
- Nameplates and Product Marking
- EVA

In addition, the PD will also develop an ISS Interface Software ICD, and a Payload-to-Launch Vehicle ICD.

### 5.1.2.2 PD-DEVELOPED INTERFACE CONTROL DOCUMENTS

As described in Paragraph 5.1.2.1, ISS Interface Requirements (ITA using the ELC), the ELC IRD (for ELC proposers) levies design, interface, and verification requirements on ISS external payloads. These requirements are imposed on a payload through an applicability matrix in the PD developed, payload-unique ICDs. The PD must create three payload-unique ICDs for flying on the ISS. The creation of the ICDs is a

significant effort imposed on the PD, and should not be underestimated. The PD will develop a hardware ICD and a software ICD, and a Launch Vehicle ICD, which details the requirements implementation methods.

The payload-unique ICDs define and control the design of the interfaces between the ISS and the payload, and the Launch Vehicle and the payload, and serves to establish commonality with respect to interface design, analytical approaches, models, test methods and tools, technical data and definitions for integrated analysis. The Payload-to-Launch Vehicle ICD is covered in Section 6.0, Launch Vehicles and Visiting Vehicles Supporting ISS External Payloads.

The engineering integration process includes assigning an ISS ICD engineer to work with the PD on ICD development. The ICD documents the payload interfaces to ISS and identifies the applicable requirements from the ISS that the payload has to meet, the verification method, due date, and verification data for each applicable requirement. The payload-unique ICD documents the implementation of the IRD requirements and ensures that they remain within the interface design parameters. ANY exception to the IRDs must be documented in the payload-unique ICDs. The ICDs will document the specific requirement violated, a description of the existing condition, and a rationale for acceptance. Finally, a crucial component of the PD developed ICDs is the verification matrix.

### 5.1.2.3 VERIFICATION

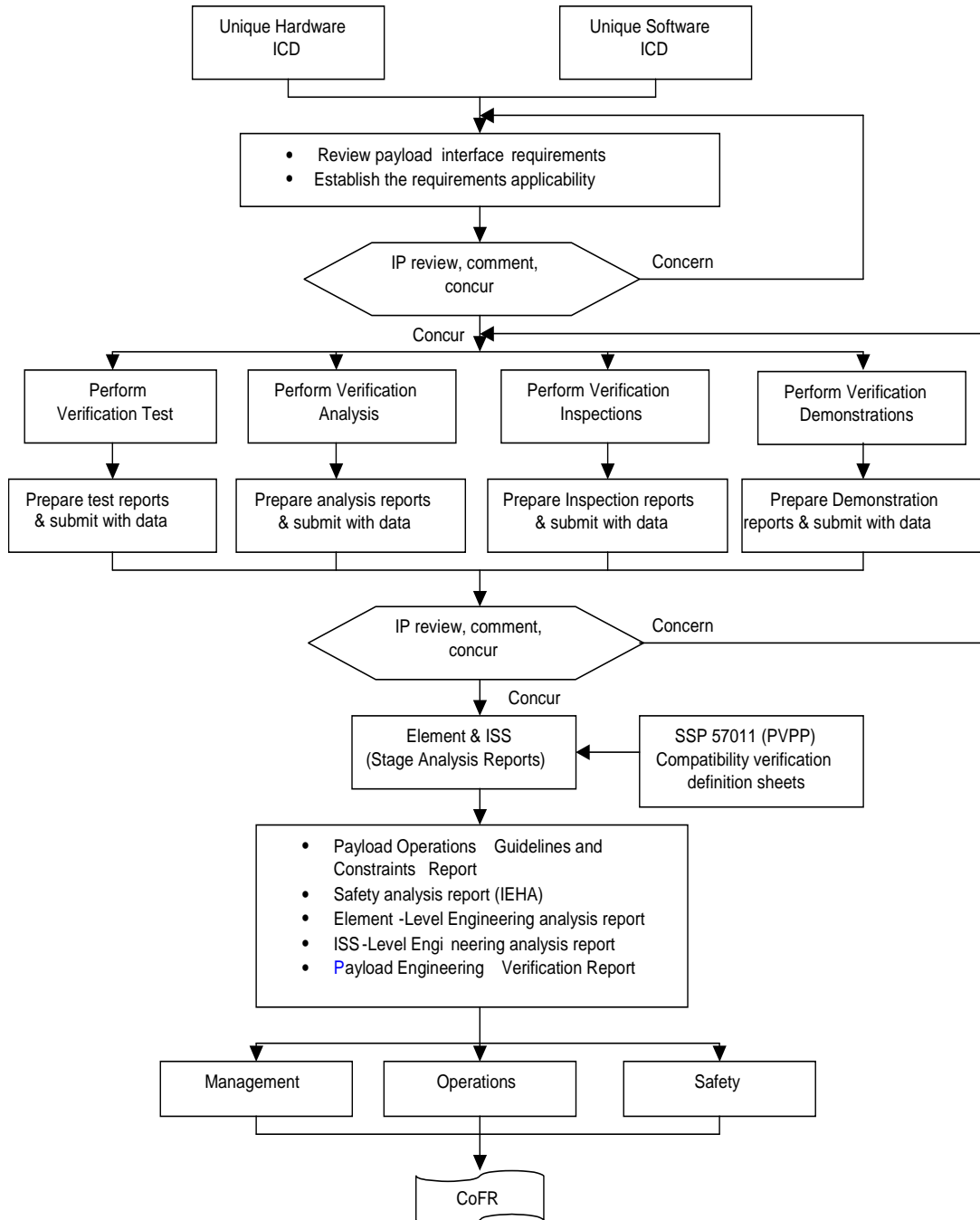
A major task creation of the ICD is the creation and completion of the verification matrix. Subsequent verification data submittals to the ISS team will utilize the verification methods contained in the ICDs. Verification methods will consist of one or more of the following:

- Analysis
- Testing
- Inspection
- Demonstration

Verification submittals based on the PD-defined verification matrix are a critical step to flying on the ISS, and requires a substantial amount of effort by the PD. Each item contained in the ICD has a corresponding requirement in the IRD and must be verified by one of the methods listed above. This is a major element to successful closure of the engineering integration tasks, and a vital point for flying on ISS. Please note that the ICD is usually at a draft state for the payload PDR and is baselined at the payload's CDR.

You will need to use the verification methods outlined in the ICD to provide evidence of verification completion to the ISS Program. The flow chart, Figure 5.1.2.3-1, Summary of Verification Process, provides a summary of the verification process, and is applicable to all ISS external payloads.

During the verification process, the PD will develop a Verification Tracking Log (VTL). The VTL is used for tracking and closing out your payload ICD, system hardware, and safety requirements prior to launch.



NOTE: There are numerous steps included in the total verification process, including performing the actual verification, preparing reports and data submittals, and review of the PDs verification submittals by various ISS organizations, such as operations, safety, and ISS management.

**FIGURE 5.1.2.3-1 SUMMARY OF VERIFICATION PROCESS**

Payload verification data are collected from the PD and reviewed by the ISS Payload Engineering Integration Team initially. After the verification data have been approved, the ISS Payload EI Team creates a verification memo for payloads launching and returning on a specific increment. The ISS will conduct numerous reviews of your verification activities, including conducting two extensive paperwork audits of your

hardware configuration to your payload ICD and applicable ISS payload requirements interfaces. One is a functional configuration audit and the second is a physical conformance audit. Together, they verify all of your payload design, manufacturing, assembly, and testing configurations through design, build, and test documentation.

As you can see, the Certificate of Flight Readiness (CoFR) is the culmination of the verification process. This critical element states that the PD has certified that their payload has passed all verification steps, including hardware and software testing, and is ready for flight. The PD must participate in the CoFR process, which consists of a series of detailed “readiness” reviews. These reviews are performed by NASA, the International Partners, and NASA Contractors.

### **5.1.3 VERIFICATION INTERFACE TESTING (PART OF VERIFICATION PROCESS)**

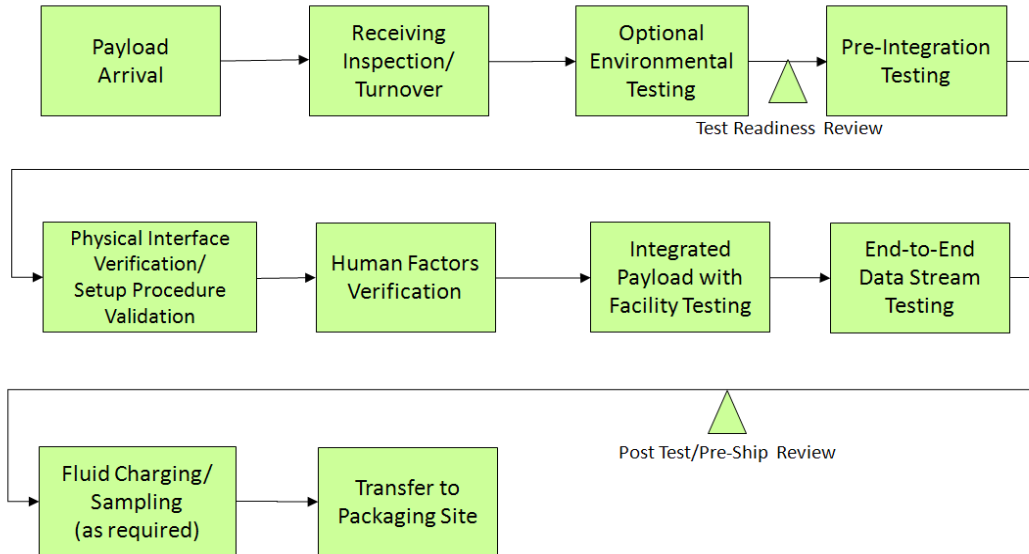
Most of the PD-developed integration products provided to the ISS are analytical in nature; however, there is a significant verification-testing component to the verification process. When a payload must interface with other facilities or payloads on the ISS, integration and interface testing is performed prior to launch. KSC and MSFC provide the infrastructure for this testing.

Testing can be categorized into payload-unique development testing and ISS verification and interface testing. ISS provides hardware to accomplish both testing phases. The ISS-provided simulators for testing are described in more detail in Section 8.0, ISS Program-Provided Hardware.

The determination of flight readiness of a payload is composed of: (1) the certification that each hardware and software element meets specific ISS requirements, and (2) the certification of these elements as an integrated payload. The final, integrated verification is accomplished by testing the payload with ground equipment that is equivalent to the facility on-board the ISS.

Testing is also used to perform final functional ISS interface testing which ensures compatibility between ISS and the payload and joint operations with other payloads, as contained in the applicable ICDs. External ISS payloads testing will generally occur at KSC. This testing will determine the readiness of the payload for flight on the ISS.

The overall generic flow for the testing process is shown in Figure 5.1.3-1. Testing Flow.



**FIGURE 5.1.3-1 TESTING FLOW**

Along with the testing process, the PD will have numerous prelaunch activities, including off-line preparations; payload integration; test and checkout; and Interface Verification Tests. These tasks are generally accomplished at KSC. An Integration Readiness Review/Test Readiness Review will be held prior to integrating the payload into the ISS facility for testing.

NOTE: Please remember that it is the responsibility of the PD to conduct payload-unique software testing during the payload development life cycle phase. Software testing can be accomplished using ISS-provided simulators.

Most integrated payload testing for the ELC is performed via the ELC Simulator, and the Active Common Attachment System Simulator, located at KSC. This hardware is configured and checked out by the ISS to support payload verification testing. Environmental testing such as vibration, EMI, off-gassing, etc. should be performed prior to arrival at the test site. If desired, the PD can make special arrangements to perform environmental testing using KSC or MSFC test facilities.

During the final integration phase, the PD's flight hardware/software is turned over to KSC for testing with ISS flight-equivalent hardware and software. This process encompasses the final verification and interface testing for flight on the ISS. After turnover via formal shipping document (e.g., DD1149), KSC has custodial responsibility for the PD flight hardware. These activities include hardware testing, integration, fluid servicing, inspections, fit-checks, etc., as agreed to by the PD and KSC, and uses ISS-provided equipment and simulators. However, the PD must be prepared to support this effort.

End-to-end data stream testing is also performed to ensure data generated from the payload operating in/with the ISS will be properly displayed on the computer screens at MSFC and the at the PD tele-science centers. KSC and MSFC have implemented the capability to test and verify high-rate data streams using simulators of the ISS external accommodations. These simulators are discussed in Section 8.0 of the Guide.

### 5.1.3.1 PHYSICAL INTEGRATION FACILITIES

The primary area at KSC that the PD may utilize for physical integration is the Space Station Processing Facility (SSPF). External payload ground handling, processing, and ground transportation requirements are specified in KPLHB 50001, Launch Site Accommodations Handbook for Payloads.<sup>13</sup> Laboratories in the SSPF building are class 300,000 clean rooms. All labs are equipped with sinks, hot and cold water, cabinets, vacuum system, compressed air, and some have one-ton crane support. The PD should be prepared to support SSPF processing for at least a week, on site.

If a PD requires non-standard services at KSC, they will be documented in the Payload Interface Agreement (PIA). The PD will provide payload-unique technical requirement inputs for these non-standard requirements that are to be levied on KSC. Non-standard services may require PD funding to implement.

### 5.1.3.2 JEM-EF ENGINEERING INTEGRATION PROCESS

The process for flying on the ISS's JEM-EF is virtually identical to flying on the ELC. However, the interface requirements for JEM-EF are contained within NASDA-ESPC-2900A.<sup>17</sup> The proposer must utilize this document to determine their specific JEM-EF interface requirements for flying on the ISS. A total of four ICDs will be required for use of the JEM-EF facility:

One ICD will be written using NASDA-ESPC-2900A<sup>17</sup> as the requirements document that covers specific interfaces between the payload and the JEM-EF facility. In addition, another ICD will be required between the ISS/JSC and your payload, as described in Paragraph 5.1.2, Engineering Integration (EI) Process. Finally, a Software and Launch Vehicle ICD is also required, as outlined in Paragraph 5.1.2.

Interface testing facilities and simulators are provided by the ISS for JEM-EF payloads, such as the Payload Rack Checkout Unit (PRCU), etc. These ISS-provided simulators are described briefly in Section 8.0.

### 5.1.3.3 COLUMBUS ATTACHED MODULE ENGINEERING INTEGRATION PROCESS

The process for flying on the ISS's Columbus Attached Module is virtually identical to flying on the ISS truss. However, the interface requirements are contained within COL-RIBRE-SPE-0165.<sup>4</sup> The proposer must utilize this document to determine their specific Columbus interface requirements for flying on the ISS.

A total of four ICDs will be required for utilization of the Columbus facility. One ESA hardware ICD will be written as the requirements document that covers specific interfaces between the payload and the Columbus facility, including, but not limited to data, power, cooling, thermal, and C&DH. Also, additional ICDs will be required between the ISS/JSC and your payload, as described in Paragraph 5.1.2. Finally, a Software ICD and Launch Vehicle ICD are also required, as outlined in Paragraph 5.1.2.

Interface testing facilities and testing simulators are provided by the ISS for Columbus Attached Module payloads, such as the PRCU, etc. These ISS-provided simulators are described briefly in Section 8.0.



### 5.1.3.4 PAYLOAD-TO-LAUNCH VEHICLE/VISITING VEHICLE INTEGRATION

Launch vehicle/visiting vehicle processing requirements and launch site support may vary with the selected launch vehicle. However, the PD must develop another ICD that complies with the requirements established in the Launch Vehicle IRD. An overview of the launch vehicles'/visiting vehicles' process is outlined in Section 6.0.

## 5.2 ISS OPERATIONS

The multinational ISS operations and management functions, including basic functions of the different organizations, are represented in Figure 5.2-1, ISS Operations and Management.



FIGURE 5.2-1 ISS OPERATIONS AND MANAGEMENT

### 5.2.1 OVERVIEW – ISS INTEGRATED MISSION ELEMENTS

Typically, the integrated mission elements for an ISS external payload include the ISS platform, which will host the Instrument Payload, the Tracking and Data Relay Satellite System (TDRSS) which transmits instrument data from the ISS to the White Sands Complex (WSC), the MCC-H at JSC which manages the American Segment of ISS, The POIC at MSFC which manages all NASA payloads on ISS, and the Payload Developer Payload Operations Center (PD-POC) and data processing facilities provided by the instrument teams. Together, these elements or mission segments ensure successful execution of the mission.

#### ISS Communications

The ISS utilizes the TDRSS Network to command, control, and maintain ISS subsystems and payloads on board the station. The network facilitates the routing of payload data to the different control centers around the world. The communication

system provides two-way voice, data, and video communications between the ISS, the MCC-H, the POIC, and payload facilities such as the PD-POC.

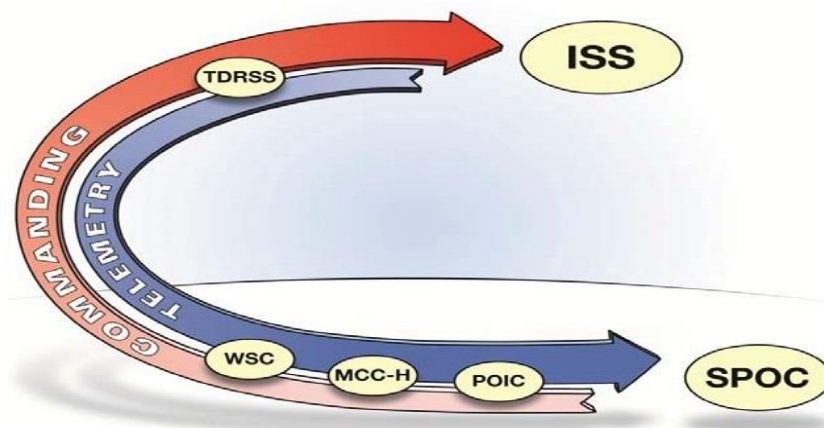
ISS communications consists of the TDRSS, the White Sands Ground Terminal, the NASA Integrated Services Network, NASA Communications System, and Internet Voice Distribution System. These resources are primarily transparent to payload operations.

### Telemetry

The POIC, located at MSFC, coordinates the transfer of telemetry, and provides short-term (up to 2 years) payload data storage for all payloads. The PD-POC then receives the telemetry in near real-time via bent-pipe approach from the POIC.

### Commanding

Commanding of payloads on the ISS requires several steps. First, the PD-POC transmits commands to the POIC. The POIC then transfers the commands to the MCC-H for uplink to the ISS. The MCC-H integrates all ISS commands, including that of the POIC, and sends them to WSC where they are uplinked to the ISS via S-band. Once on-board, the commands are identified by on-board ISS processors and sent to the instrument payload, and the commands are verified through command responses and telemetry. In the event of a failure of the command link between a remote site and the POIC, the POIC may provide backup command capability if necessary. This backup command capability is limited and is provided by the Payload Operations Integration Function (POIF) Cadre. POIF is the Flight Control Team in charge of ISS Payload Operations. A typical command and telemetry path is provided in Figure 5.2.1-1, Typical Command and Telemetry Path.

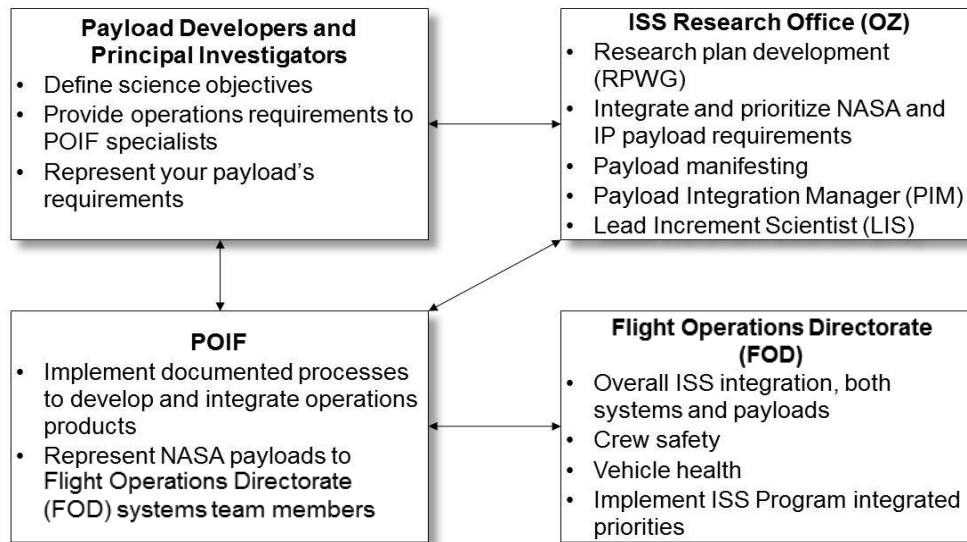


**FIGURE 5.2.1-1 TYPICAL COMMAND AND TELEMETRY PATH**

## **5.2.2 PAYLOAD OPERATIONS INTEGRATION FUNCTION (POIF)**

The POIF is a combined civil service and contractor team tasked to perform payload operations integration for all NASA payloads, located at NASA's MSFC, that coordinates, integrates, and manages payload operations planning, crew training operations products, payload safety, and ground personnel training. The POIF staffs the flight control team positions in the POIC control center, whereas the POIC Operators are responsible for facility interfaces and internal facility data system

operations. The POIF and POIF Flight Control Team (FCT) provide 24-hour a day, 7-day a week (24/7) ISS operations support for real-time command and control of NASA ISS payloads and support systems. Figure 5.2.2-1, ISS Payload Operations Organizational Interfaces, provides an overview of the interfaces between the Payload Development Team and the ISS RIO, the Flight Operations Directorate (FOD), and the POIF.



**FIGURE 5.2.2-1 ISS PAYLOAD OPERATIONS ORGANIZATIONAL INTERFACES**

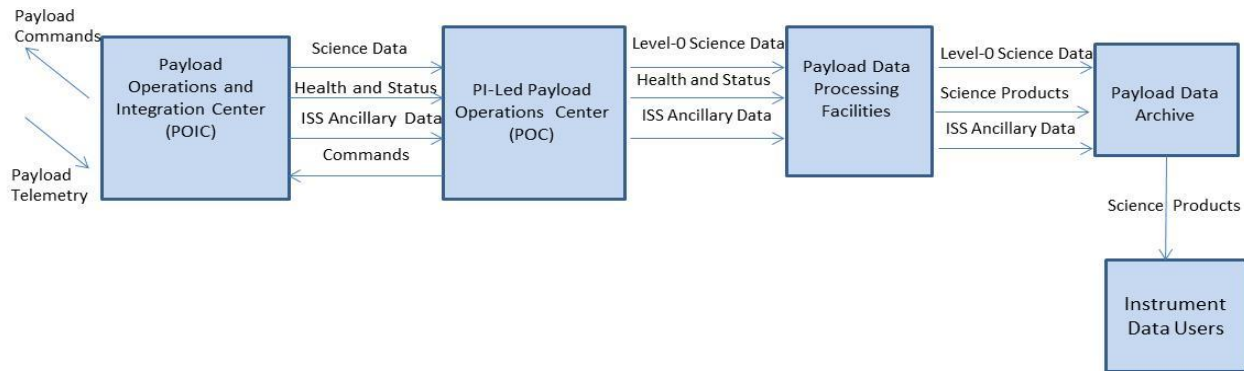
The POIF manages all NASA payloads on board the ISS. POIF responsibilities include managing ISS payload commanding, monitoring Health and Safety (H&S) of the payload, and collecting, processing, and routing of payload data to payload control centers. A POIC Customer Service Team (CST) member will be assigned to provide an early understanding of all Huntsville Operations Control Center (HOSC) ground data services.

The POIC CST is responsible for supporting the development of your Ground Data Service (GDS) needs:

- Provide detailed explanation of the POIC's ground services.
- Work with the customer to provide a "best fit" set of POIC ground support services that satisfy the customer's ground operations concept.
- Assist the customer with documenting their GDS needs in the appropriate Program Level and POIC requirement documents.
  - PIA Letter
  - Ground Data Service Blank Book
- Provide cost impacts to optional services or other unique customer GDS needs.
- Coordinate the creation and integration of all the customer GDS needs with customer's host support facilities.
- Ensure Payload Operations team training on POIC GDS.

- Provides a POIC single point-of-contact for GDS needs for the full life cycle of the experiment's operations.
  - Pre-mission
  - Mission
  - Post-mission

The POIC sends payload commands to the MCC-H for transmission to the ISS. The PD is responsible for the generation of payload commands, which are typically generated at the PD-POC; however, ultimate authority to command the payload will come from the POIF. Figure 5.2.2-2, typical POIF to PD-POC Interface and Data Flow, provides a typical interface diagram and data flow for an ISS payload.



**FIGURE 5.2.2-2 TYPICAL POIF TO PD-POC INTERFACE AND DATA FLOW**

The POIF provides command anomaly resolution support for any failed or lost payload commands, and monitors the H&S of all payloads 24/7 (with a smaller, minimal operations team during the off shifts). The POIF will notify Payload Operations Center (POC) operators if an out-of-limits situation is detected or if the payload must be placed into survival mode. The POIC has the ability to store all unprocessed payload telemetry and science data for up to 2 years, and has the ability to transmit real-time science to the POC and perform Level-0 processing on all data.

### 5.2.3 MISSION OPERATIONS FUNCTIONS

Typically, mission engineering and planning operations for external payloads will be carried out at the PD-POC with support from the POIF for mission-critical functions. The level of autonomy, and thus the level of manpower, required to support on-orbit operations, will determine complexity of both the ground system and ultimately cost of operations. ISS payload operations support requirements for typical ISS external payloads range from 8 to 5 to 24/7 depending on the science requirements and level of ground system autonomy.

#### Mission Planning

Operations planning is performed by PD operations team. Once again, the level of on-board autonomy will determine the level of effort required for mission planning. An instrument payload with significant on-board autonomy will allow for minimal mission planning during nominal operations.

Typically, PD-POC operators develop and utilize mission-planning aides to perform functions such as determining when science observations may be scheduled. Before every increment, the PD coordinates with the POIF's Payload Planning Managers (PPM) for inputs into the On-board Operations Summary and the Increment specific Execute Planning Ground Rules and Constraints (Gr&C). During the increment, the PD-POC works with the PPMs to develop inputs into the Weekly Look-head Plan and the Short Term Plan that includes commanding and data downlink times and durations. The PD-POC also coordinates with the POIF regarding ISS events such as visiting vehicles, microgravity timelines, and collision avoidance, which may impact the ability to perform science on the ISS.

#### Flight and Ground Software Management

Typically, instrument flight software and the ground processing software are managed and maintained by the PD at the PD-POC, including any modification and testing of the software. All PD-managed software must be under CM control throughout the mission life cycle.

#### Instrument Payload Commanding

POC operators plan and develop all command loads for the instrument payload. Command loads are developed and tested at the PD-POC prior to being transmitted to the POIC for uplink to ISS. The command loads are typically developed and tested the week prior to transmitting it to the POIC. The frequency of this process is largely dependent on the science mission and instrument design. For a typical mission, command loads are transmitted to the POIC for transmission to the ISS via the MCC-H and TDRSS.

#### Status Monitoring and Trending

The PD-POC is responsible for analyzing real-time spacecraft H&S data, and performing long-term trending of housekeeping data. Typical PD-POC tools will automatically select, store, trend, display, and report spacecraft housekeeping data. The PD-POC telemetry monitoring system notifies payload operators whenever an out of limit situation occurs.

#### Anomaly Ground Response

The first line of ground response for an ISS external payload is the 24/7 POIF/POIC team where the operator's action is authorized in the Payload Regulations for pre-defined anomalies. Once an anomaly has been identified, the next step is to assure the safety of the instrument (or take immediate action to safe the instrument) and then perform an initial report, including logging it into a Nonconformance Reporting System. The PD then develops a recovery plan (if required) and performs the necessary actions to recover the payload to an operational state. The POIF/POIC operators are notified of any instrument or ground issues via red or yellow alarms or ground system displays.

#### Training

Flight operations personnel receive training on the processes and procedures necessary to conduct the mission activities successfully. The typical training program

will begin approximately 1 year prior to launch. The PD and POIF are obligated to develop and administer training on their respective systems prior to launch. Integration and testing activities and the training program begins prior to L-1 year.

### Communication

ISS uses TDRSS for its communication, which allows for real-time communications; however, approximately 30% of the time there is no communication with ISS. To ensure no communication is lost due to communication limitations, the PD may decide to include a data recorder in the instrument package or accept some additional risk and elect to use the Ku Comm Unit recording capability for Loss of Signal (LOS) recording.

### **5.2.4 PAYLOAD DEVELOPER REQUIREMENTS FOR OPERATIONS**

Throughout the mission life cycle, the PD will work closely with the POIF team to develop the necessary processes, procedures, and operations products necessary to ensure the H&S of the payload, and success of the mission. The key processes and procedures required for a successful launch and payload operations include Gr&C, Flight Rules, Payload Regulations, Ground Command Procedures, Command and Telemetry Databases, and Crew Training Package and are described below.

### Ground Rules and Constraints (Gr&C)

Gr&C list specific payload planning requirements, constraints, or other basic ground rules which are crucial for experiment success and the H&S of the payload. They are distributed to PD teams by email for *Informal* review at L-2.25 months and for *Final* delivery at ~L-1 month. Gr&C are incorporated into the ISS Increment Specific Execute Planning Gr&C which includes ESA, JAXA, and NASA/CSA payloads for each increment. The Gr&C requirements and processes are further described in the Payload Operations Handbook, Volume 1, Paragraph 7.2,<sup>51</sup> Payload Increment-Specific Gr&C Development.

### Flight Rules

Flight Rules are published by the ISS Flight Director Office, enforced in real-time by the Flight Director, and are adhered to by all partner control centers. The Flight Rules, unique to each payload, are defined primarily to maintain crew safety, ISS and visiting vehicle integrity, and document mission success criteria. Flight Rules and requirements for the PD teams are further discussed in SSP 58311, Payload Operations Integration Center Payload Operations Handbook, Volume 1: Pre-/Post-Increment Operations<sup>50</sup>.

### NASA Payload Regulations

NASA Payload Regulations are rules and constraints designed to maximize payload mission success and minimize conflicts between/among payloads. Payload Regulations are published by POIC and adhered to by POIC and NASA PD teams. Payload regulations and requirements for the PD team are discussed in SSP 58311<sup>50</sup>.

### Flight Rules/Payload Regulations Publication

Flight Rules are updated periodically, but not necessarily on a flight-by-flight basis. The POIF collects payload Flight Rule candidates starting at L-7 months. The Payload Operations Directorate will coordinate with the Flight Operations Directorate (FOD) to

publish the updated payload-specific Flight Rules. The PD team can expect to begin development of Payload Regulations at L-7 months. The deadline for Payload Regulations is L-2 months. Payloads launching on flights not corresponding to increment boundaries, will have their Payload Regulations incorporated at the logical increment mark, or updated by Operations Concept Review.

Flight Rules updates and Payload Regulations are further discussed in SSP 558311<sup>50</sup>.

#### Ground Command Procedures (GCPs)

GCPs contain detailed step-by-step instructions for POIF operations personnel to control and monitor payloads and the ISS systems supporting those payloads. The GCP Book Manager will work with the PD team and Operations Lead to develop new or update existing GCPs to support the mission. GCPs are under strict configuration control, updates for new payloads are controlled by the Engineering Change Request (ECR) process. The GCP Book Manager submits the ECR at L-3 months.

Inputs required by the PD team include but are not limited to:

- Safing procedures
- Commands delegated to the POIF
- Station resources that may be required
- H&S parameters to be monitored and associated steps to respond
- Unique resources or systems configurations

GCPs and PD team requirements relative to the development and/or update of GCPs are further discussed in SSP 58311<sup>50</sup>.

#### Payload Command and Telemetry(C&T) Databases

Payload C&T databases are built by the POIF using PD team inputs entered in the C&DH data set. C&T database builds are generated on an increment basis; data for the first revision of a database must be in Payload Data Library (PDL) at ~L-8 months.

Preliminary versions are provided to the PD team and the POIF/POIC FCT for testing at ~L-7. Depending on the payload development, integration and test, or operations test schedules, the C&T database may be required prior to L-7. If the C&T database is required for testing earlier than L-7, the PD team must request and coordinate dates through the Payload Software Control Panel All C&T database changes/corrections resultant from testing must be updated in the C&DH Data Set. Data for the flight rev of the databases must be in PDL by L-5 months and available for use/testing at L-4 months. During increment operations, transitions to new databases are pre-coordinated, then scheduled and executed. The POIF Database Lead is the primary point of contact for C&T database questions.

C&T databases and PD team requirements are discussed in detail in SSP 58311.<sup>50</sup>

#### Payload Training

Payload Training for the POIF FCT is conducted by the POIF. The POIF Operations Lead builds the payload training materials which can be in the form of either a computer-based training or an operations summary. The PD team will provide

information for the development of training materials during the training package development and baseline phase. Refer to SSP 58311<sup>50</sup> for additional detail.

### 5.2.5 DATA FLOW PLANNING

Data flow planning is performed by the Data Management Coordinator (DMC) Team and coordinated with the mission elements including the POIF and the PD team. Data latency requirements are typically defined in a payload's Level-1 requirements and are within the ISS specification for data downlink and latency.

Payloads share bandwidth with ISS systems data downlink requirements. The planned routings and configurations of the on-board data, including ISS payload data, are defined in ISS Data Flow Plan which is used by the DMC to manage these systems for real-time execution.

Data flow analysis is performed real-time and contains the initial plan for data and video system configurations, including start/stop times of data and video producing activities, TDRSS coverage, and recorder management. To plan the routings and configurations for U.S. payloads accurately, payload data and video requirements must be reviewed and understood by the DMC Team during the increment preparation.

### 5.2.6 DATA DOWNLINK CAPABILITY

The summary of the current ISS data downlink capability and parameters are provided below, which should be helpful to the PD in assessing and designing their payload data capabilities.

- Current throughput pipe allocated to science data: The system is sized for 259 Mbps (after overhead has been taken into account). Out of that 259 Mbps, about 100 Mbps is typically allocated to systems. The remainder (currently 159 Mbps) is used for science data downlink. This is for all ISS payloads (excluding Russian payloads). Out of that payload available bandwidth 12% is allocated to JAXA payloads; 8% of it is allocated to ESA payloads; the remainder is for NASA payloads.
- ISS onboard storage size, data rate recording and downlink rate: The sustainable record rate for ISS Ku Communication LOS recording is around 100–120 Mbps. At this rate with appropriate reserved playback bandwidth the system can record and playback continuously. If there were that much recording occurring, it would need something on the order of 45–60 Mbps reserved just for playbacks based on 70% Ku coverage and 30% LOS (record time). Current trends show requirements for recording much lower than that (about 5–30 Mbps is the typical range as of early 2015). The required recording rates vary with the complement of activities scheduled for operations on ISS.

The Recording capacity is 300 GB of space. This space is currently divided ~ 20/80 to systems/payloads activities. This division is configurable based on coordination in planning between systems and payload operations teams to determine where space is needed to support scheduled operations.

- Frequency and percentage of data from the ISS onboard recorder that is downlinked from ISS when TDRSS is available: The Ku Communication Unit



recorder is a Communications Outage Recorder. This means its design was based on recording data gaps (during LOS) only. During nominal operations POIC utilizes what is called “Auto Ops” mode recording which automatically stops recording during communication coverage windows and starts recording when communication coverage is lost.

If necessary due to failures of the on board communication system, TDRSS, or ground systems, POIC can place the Communication unit in manual record for the duration of the issue or until storage runs out. To date there has never been any incident where the onboard storage ran out of space due to high rates, or a failure.

ISS science data recorded during LOS is downlinked during every viable Ku coverage window. In practice, this means anything recorded typically reaches the ground within 3 hours. The vast majority is downlinked in the first viable pass after it is recorded (typically within 30–45 minutes).

- Amount of science data (on average) within a 24-hour period: It averages out to be around 25–30 Mbps stream of actual throughout on a given day as of Early 2015. This is subject to the complement of experiments going on at any given time. There is also a significant discrepancy between the actual rates observed and the required rates that are scheduled. For example, at present, based on requirements POIC probably has more like 50–75 Mbps scheduled support on average.
- Typical latency for science data from ISS to a Principal Investigator’s location: The round trip for the JSL-2 (HOSC Payload Ethernet Gate (HPEG)) is approximately 700 ms. The one-way trip should be about half of that, so the latency is about 350 ms.
- Typical daily estimate of Ku (TDRSS) coverage: A realistic Ku coverage estimate is about 70% on average. During high beta it can drop to as low as 50%. During crew wake periods, it is often as high as 85%.
- Health and Status data downlink summary:
  - Health and Status data is always in the downlink and is transmitted immediately once Ku coverage is resumed.
  - Payload Health and Status is currently limited to 256 kbps (from all active Payloads connected to Payload local buses). Payload health and status is downlinked at 1/sec
  - Health and Status latency time from ISS to Principal Investigator’s location is approximately 270 ms

### 5.2.7 ADDITIONAL OPERATIONAL CONSIDERATIONS – RESOURCE SHARING

The PD should be aware of limitations during ISS operations. For example, JEM-EF power and thermal conditioning resources are shared among the JEM-EF payload complement during on-orbit operations. Although the capability exists to receive the entire power and thermal allocation at a specific JEM-EF location, this allocation is divided among all the payloads at the JEM-EF site. The same scenario for on-orbit operations also exists for the Columbus external payload complement. The operational

power for Columbus is shared among the entire Columbus external payload complement.

Therefore, the PD should provide accurate predicted operational power requirements (JEM-EF and Columbus external sites) and thermal (JEM-EF only) during their proposal process, so that the ISS Program can assess the feasibility of the requested resource accommodation for that payload.

### 5.2.8 EVA OPERATIONS

EVA operations: It is inevitable that EVAs occur during your time on the ISS. These operations, unless for an emergency, are typically planned in advance, and you will be aware of when they occur. But, the EVAs have the potential to interrupt your operations. It is highly advisable that you maintain vigilance for EVAs and be prepared to plan around them. Figure 5.2.8-1, ISS U.S. Past and Predicted EVAs provides both an historical record of EVAs, and a predictive aspect for EVAs that may occur between 2016 and 2019. In total, this figure will provide you with valuable information on the number of EVAs that affect your payload operations.

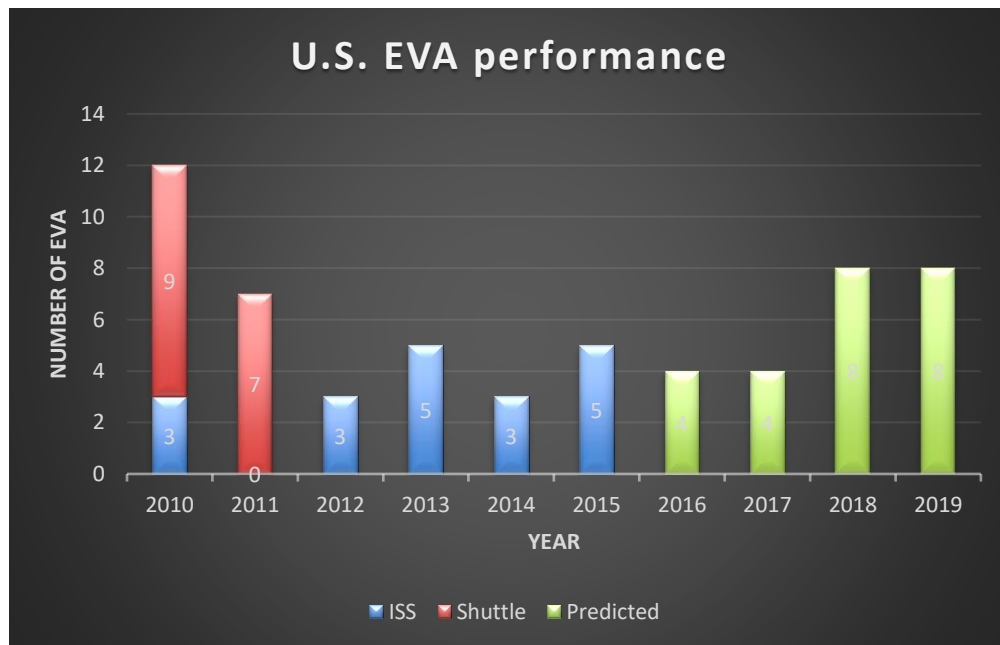


FIGURE 5.2.8-1 ISS U.S. PAST AND PREDICTED EVAS

### 5.2.9 CONTINGENCY EVA (AS REQUIRED)

For external payloads, only contingency EVA is available, and the PD should not expect contingency EVA to restore mission success. Contingency EVA would normally only be performed to address major issues, such as the case of ISS robotic failure, and other issues concerning vehicle and/or crew safety. In any case, EVA safety requirements must be addressed for your payload design.

### 5.2.10 VISITING VEHICLE TIMELINE

The operation of the ISS is defined and planned in increments — characterized by time between major events such as spacecraft docking and undocking. Payloads will be required to operate across multiple increments and must plan science and payload operations across multiple docking events. The PD should define an operational procedure which includes these events, which may include, but not limited to, closing a payload aperture door, ceasing LIDAR operations for a short period, etc. The visiting vehicle profile (Figure 5.2.10-1, Visiting Vehicles) provides the currently planned number of visiting vehicles to fly to ISS, though FY 2019. It must be noted that this profile will most assuredly change in the coming months from the published date of The Guide.

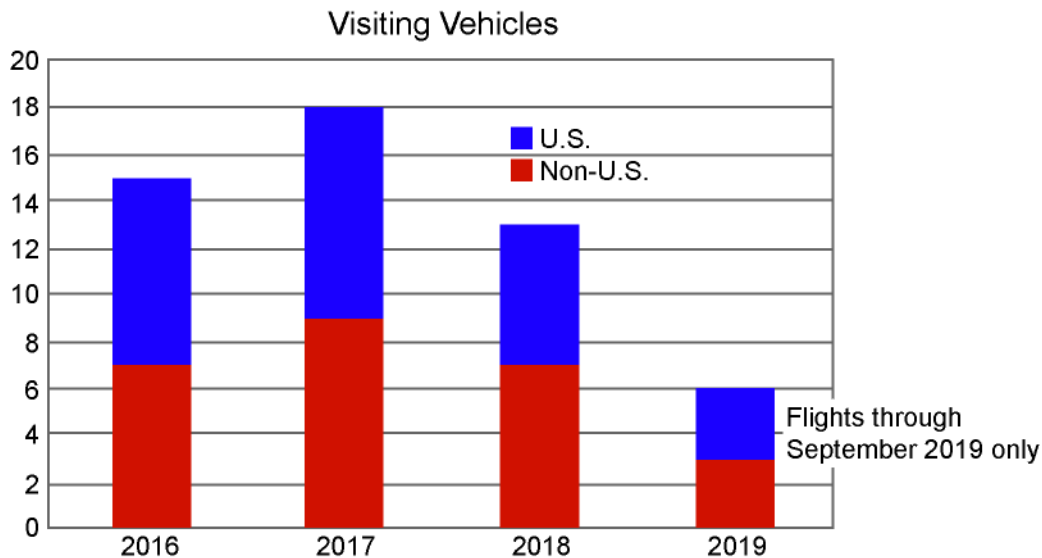


FIGURE 5.2.10-1 VISITING VEHICLES

### 5.2.11 OPERATIONS PRODUCT SUMMARY

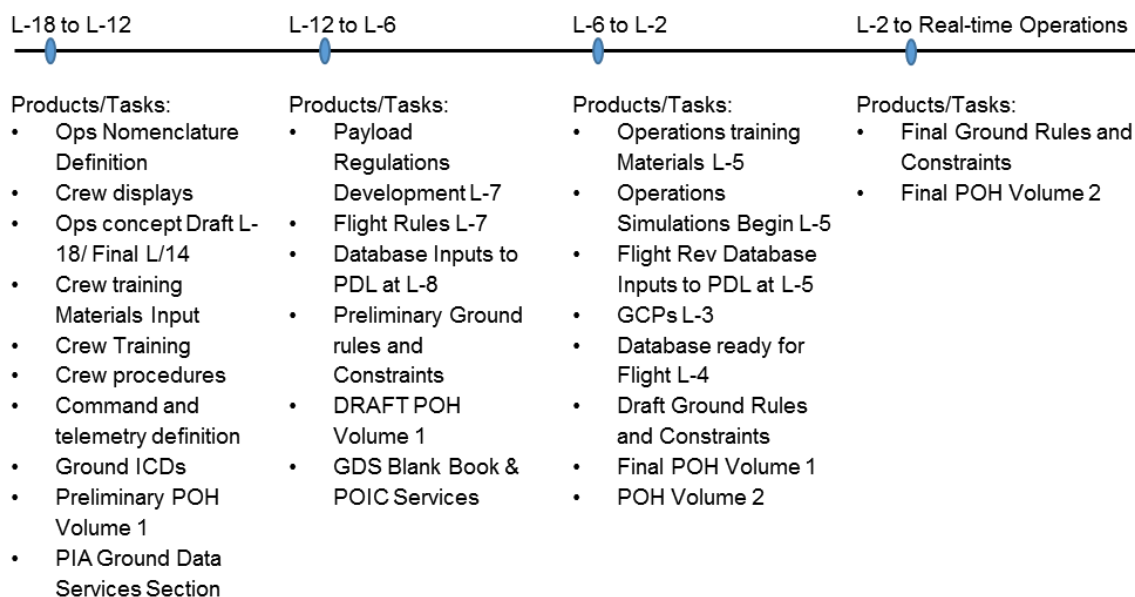
In summary, the PD team works closely with the POIF and POIC in the development of operations products for testing and on-orbit operations. As such, it is crucial that the PD team provide timely inputs to operations products such as:

- Planning data set
- Crew procedures
- Displays
- Crew training requirements
- Ground command procedures

- Payload regulations

The POIF is the PD team’s interface to the ISS Program during increment preparation, ground testing, and real-time operations. It is crucial that the PD team work with POIF and POIC personnel to understand fully the operations concepts, hardware, software, and payload specifics including system Interfaces, commands, data, video, unique resources, and hazard controls. The PD team must provide a GDS HOSC CST Representative to identify ground support service needs and GDS Blank Book completion as well as GDS support from the payload’s host operating location(s). This support service includes network management, systems management, IT Security, and ground services testing.

Figure 5.2.11-1, Operations Products Timeline, provides a list of data input products, and a relative time schedule for tasks/product completion.



**FIGURE 5.2.11-1 OPERATIONS PRODUCTS TIMELINE**

### 5.2.12 END OF MISSION

A payload will have a finite lifetime on-orbit, determined by ISS manifesting priorities and payload science value.

Generally, a payload will be removed from its position either shortly before or after arrival of the visiting vehicle that is bringing the replacement payload, according to the ISS manifest. A payload is required to return within the payload’s launch envelope. If a malfunction can prevent the payload from returning to within launch envelope by command, the payload is required to have robotic interfaces (hex head bolt(s), micro-square or micro-conical(s), target(s) which will enable an EVR-assisted configuration for disposal of the payload.

Once the payload is configured for disposal and commanded off (and relying on contingency heaters), the removal process begins. Removal is the reverse of the installation procedure, and ends with the payload configured for disposal in the visiting

vehicle. However, the order is typically to remove the old payload, set it in a temporary parking position, retrieve the new payload from the visiting vehicle and install it, then retrieve the old payload from its temporary position and configure the payload for disposal in the visiting vehicle. After reinstallation of the payload into the visiting vehicle, the vehicle will reenter the atmosphere, and burn up, based on the current return vehicle capabilities.

## 6.0 LAUNCH VEHICLES AND VISITING VEHICLES SUPPORTING ISS EXTERNAL PAYLOADS

### 6.1 OVERVIEW

Currently, only one vehicle provides launch services to the ISS for ISS external payloads: the SpaceX Falcon 9 (see Figure 6.1-1, SpaceX Falcon 9). (The HII Transfer Vehicle, jointly developed by JAXA and Mitsubishi Heavy Industries, is launched once a year and unlikely to transport external payloads to the ISS. For this reason, it is not included in the Guide.) SpaceX issued a new Users Guide, Falcon 9 Launch Vehicle Payload User's Guide, Rev. 2,<sup>52</sup> in October 2015. This Guide should be consulted for interface and accommodations data for the Falcon 9 launch vehicle. The SpaceX guide may be found at:

[http://www.spacex.com/sites/spacex/files/falcon\\_9\\_users\\_guide\\_rev\\_2.0.pdf](http://www.spacex.com/sites/spacex/files/falcon_9_users_guide_rev_2.0.pdf).<sup>52</sup>

In addition, PDs may also need to refer to the latest version of SpaceX document C3-1 Dragon Interface Definition Document Appendix: Dragon Cargo Flight Environments (only).<sup>53</sup>



**FIGURE 6.1-1 SPACEX FALCON 9**

The ISS Program has just completed a procurement for additional ISS flights, as of the time this version of The Guide was developed. This follow-on contract, referred to as the Commercial Resupply Services (CRS)-2 contract, has resulted in three contractor organizations and their corresponding vehicles being selected for future flights to the ISS. The contractor selectees were: the SpaceX Falcon/Dragon, Orbital ATK Antares/Cygnus, and the Sierra Nevada Dream Chaser. The CRS-2 flights will begin at the conclusion of the CRS-1 contract. It has not been determined if additional capabilities for flying external payloads will accompany these additional vehicles. Therefore, the selection of a visiting vehicle COULD change for future ISS flights. Please confer with the ISS Payloads Office for the most current vehicle availability.

#### **6.1.1 FALCON 9 LAUNCH VEHICLE**

The Falcon 9 launches the CRS from KSC in Cape Canaveral, Florida (see Figure 6.1.1-1, Falcon 9 Liftoff). This contract between NASA and SpaceX guarantees at least 18 launches to the ISS and is currently underway. The Falcon 9 itself is a two-stage

vehicle with an eight-engine configuration in the first stage and a single engine in the second stage. It is integral to note the first stage can still perform to mission standard even with two engines non-functional during an anomaly. Eventually, the Falcon 9 will be completely reused, as all stages will land autonomously to be serviced.



**FIGURE 6.1.1-1 FALCON 9 LIFTOFF**

For payloads launched on a SpaceX vehicle, the payload's launch-site ground processing requirements will be levied and controlled by the SpaceX flight-specific launch-site support document. Payload ground processing requirements at the SpaceX launch complex shall be negotiated between the PD and the ISS. Requests for power and/or data during transport on the SpaceX vehicle shall be documented in the PIA. In general, SpaceX will provide a payload processing facility (PPF) and launch site. In general terms, the unpressurized cargo owner will arrive at PPF and be moved into facility where PD can perform short duration offline work. Upon completion, the payload will be turned over to SpaceX who will integrate payload into trunk. Currently, vehicle flight-support equipment manufacturing begins at L-18 months. PD hardware must be delivered to KSC at L-3 months for ISS inspections, and then must be delivered to SpaceX at L-2 months, and payloads will be loaded and integrated onto the vehicle at about L-9 days. Late-load accommodations are also available.



## 6.1.2 DRAGON

Dragon is a fully autonomous spacecraft with both pressurized and unpressurized sections (see Figure 6.1.2-1, Dragon). Dragon is composed of two main elements: the pressurized cargo module, or “capsule,” and the unpressurized cargo module, or “trunk.” The capsule performs all the functions of a service module. It includes a pressurized section, a service section, and a nosecone, and contains all the structure and subsystems required for transport of pressurized cargo to the ISS. The trunk is an aluminum welded and riveted structure that provides external cargo capability in addition to serving as the adapter between the Dragon capsule and the Falcon 9 launch vehicle.



**FIGURE 6.1.1-2 DRAGON**

The trunk also serves as a platform for the Dragon solar arrays and radiator. The trunk remains attached to Dragon throughout launch and ISS attached operations but jettisoned shortly before reentry. Unpressurized cargo that is both mounted directly or by FRAM, can be accommodated by the cargo rack within the trunk. Disposal cargo may be stowed in the trunk for jettison prior to reentry.

Volume available for cargo in the trunk, accounting for static and dynamic clearances, is shown in Figure 6.3.1-2, Dragon Major Components. Total volume is 601 cu ft. (17.0 m<sup>3</sup>). The volume is defined from the trunk cargo rack; the cargo rack is not included in the volume. Allowable payload volume is shown in gray. Keep-out zones are denoted in purple and inside the dashed lines. A detailed CAD model of the trunk is available for volumetric assessments on NASA CAD Model team website/Enterprise Document Management System.

The only service provided by the Dragon, excepting structural attachments, is survival power, listed in Table 6.1.2-1, Dragon Overview. Currently, there is no command and data capability, or other services, for external payloads available in the Dragon capsule

trunk. NOTE: This list DOES NOT include all payload constraints for the vehicles. Other conditions, such as vibrations, acoustics, and pre-launch environments can be obtained through the launch vehicle/visiting vehicle User's Guides, ISS document SSP 57012<sup>48</sup> and by contacting the sponsoring organization, and your PIM.

Dragon trunk will nominally provide no more than an average of 200 W for the total external cargo manifest. Overall external cargo mass shall not exceed 3000 kg.

**TABLE 6.1.2-1 DRAGON OVERVIEW**

	Dragon
Height	5.1 m
Payload volume	Unpressurized: 14 m <sup>3</sup>
Payload mass	Unpressurized: 3,000 kg (total, including ISS resupply)
Power output	20 W
Flight thermal	≤93 °C (200 °F)
Data	N/A in Dragon trunk
Attachment Capabilities	Can use ExPA/FRAM, JEM-EF attachment or mission-specific attachment mechanism

In addition, as ISS external payload is contained within the Dragon, PDs will also need to refer to the latest version of SpaceX document C3-1 Dragon Interface Definition Document Appendix: Dragon Cargo Flight Environments (only).<sup>53</sup> As this document is updated regularly, it is important that the PD contact the ISS RIO for the latest version. As the Dragon Interface Definition Document (IDD) is updated frequently, no interface loads and accommodations are included in the ISS Proposers Guide.

In addition, the proposer should be aware of the contamination environment within the Dragon capsule. Special provisions or designs may be required from SpaceX or the PD in meeting specific payload contamination requirements. The PD should inquire about the latest contamination environments applicable to Dragon.

## 6.2 LAUNCH AND INTEGRATION OVERVIEW

### 6.2.1 GENERAL LAUNCH MILESTONES

Important milestones, such as dates by which critical documents must be submitted to organizations, can be found in Paragraph 5.1.1, Integration Template, or OZ-10-056.<sup>23</sup> Table 6.2.1-1, Major Launch Vehicle Milestones, provides a top-level view of important milestones. However, each launch vehicle/visiting vehicle has different milestones depending on the type of payload and specific mission details. The milestones listed above are representative of general launch vehicle milestones. These milestones may change, to some degree, based on unique flight parameters.

**TABLE 6.2.1-1 MAJOR LAUNCH VEHICLE MILESTONES**

Baseline and Procure Launch Services	~L-3-2 years
Launch Site Operations	~L-6 months to L-10 days
Launch	~L-10 days to Launch
Post-Launch	~To L+3 months

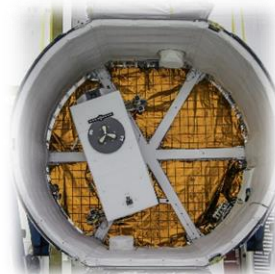
**6.2.2 INTEGRATION SCHEDULE**

A typical Falcon 9 integration schedule (starts at ~L-59 days) is contained below:

1. Payload is vertically integrated at a PPF Cape Canaveral, for example.
2. Payload and vehicle adaptor are attached over a “break-over” fixture at the PPF.
3. The payload is rotated horizontally and encapsulated by the fairing. At this point, the payload is no longer fully accessible, and can only be accessed by an 18 x 18-inch door on the bottom of the fairing.
4. The encapsulated payload is transported to the launch complex. During this process, it remains completely horizontal for easier integration.
5. The payload and launch vehicle/visiting vehicle are integrated mechanically inside the hangar. Mechanical integration is done first to ensure payload meets the physical constraints of the vehicle and launch procedure.
6. Once the mechanical mating is confirmed, the electrical umbilical connections are established between the payload and the second stage. If necessary, electrical connections are also made between the ground support equipment and the payload.
7. The electrical interface is reassessed. Once it is verified again, the launch vehicle/visiting vehicle is transferred to the launch pad and put into a vertical position. At this point, the payload can no longer be accessed. For a short time during this process, conditioned air will be unavailable as new connections are made.
8. At L-7 days, the Flight Readiness Review (FRR) takes place to ensure no major problems in the launch procedure.
9. Final connections between ground support, vehicle, and launch pad are verified.
10. The pre-launch environmental controls are terminated and the vehicle is launched.

**6.2.3 MISSION PROFILE**

The following images represent a typical mission profile of the Falcon/Dragon launch to the ISS, in sequential order.



**2. Launch Processing:** After handover to SpaceX, all Launch Site Processing for

1. Delivery of integrated payload to SpaceX PFF or launch site LC-40.



Payload including integration to Cargo Rack in Dragon Trunk.



3. Launch: Launch of Dragon carrying Payload on Cargo Rack in Dragon Trunk.

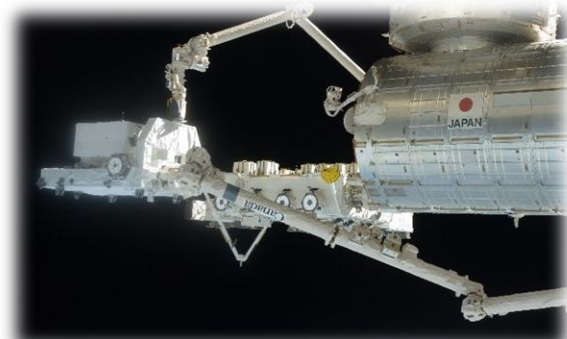


4. Free Flight to ISS: Dragon Free Flight carrying Payload to ISS on Cargo Rack in Dragon Trunk.



5. Berthing: Dragon berthing to ISS carrying Payload on Cargo Rack in Dragon Trunk.

6. On-orbit Extraction: Dextre extracting Payload from Cargo Rack in Dragon Trunk.



7. Cargo Work Site Operation: Payload transported to ISS location by SPDM or SSRMS. (This phase does not involve SpaceX or Dragon.)

8. Payload Disposal: Payload transported back in Dragon Trunk for disposal.



9. De-berthing: Dragon de-berthing from ISS.



10. Departure: Dragon departure from ISS and Free Flight.



11. Reentry: Dragon reentry, disposal of Dragon Trunk.



12. Recovery: Dragon recovery.

#### 6.2.4 IMPORTANT INFORMATION REGARDING DOCKING

Vehicles flying towards the ISS will park ~10 m from the ISS. The two vehicles that physically dock with the ISS are the Dragon, deployed from the Falcon 9, and Cygnus, which is deployed by the Antares launch vehicle. (However, only Dragon can currently carry external payloads to the ISS.) The ISS robotic arm SSRMS will grab the vehicle and attach it to a designated attachment site. There are three available attachment sites: Node 1 Nadir, Node 2 Nadir, and Node 2 Zenith. The ISS robotic arm will then transfer the payload from the vehicle to the destination attachment site. During this time, the payload must be able to survive without electrical and thermal accommodations. This process may take 6 hours for robotic transfer to the ELC or Columbus-EPF from the Dragon. However, transfer of a payload from a visiting vehicle to the JEM-EF attachment sites may take 7 hours because it requires a handoff from the SSRMS robotic arm to the JEM robotic arm.

The payload must be able to survive these times without power as a condition for flight.

## 6.3 CUSTOMER ACCOMMODATIONS

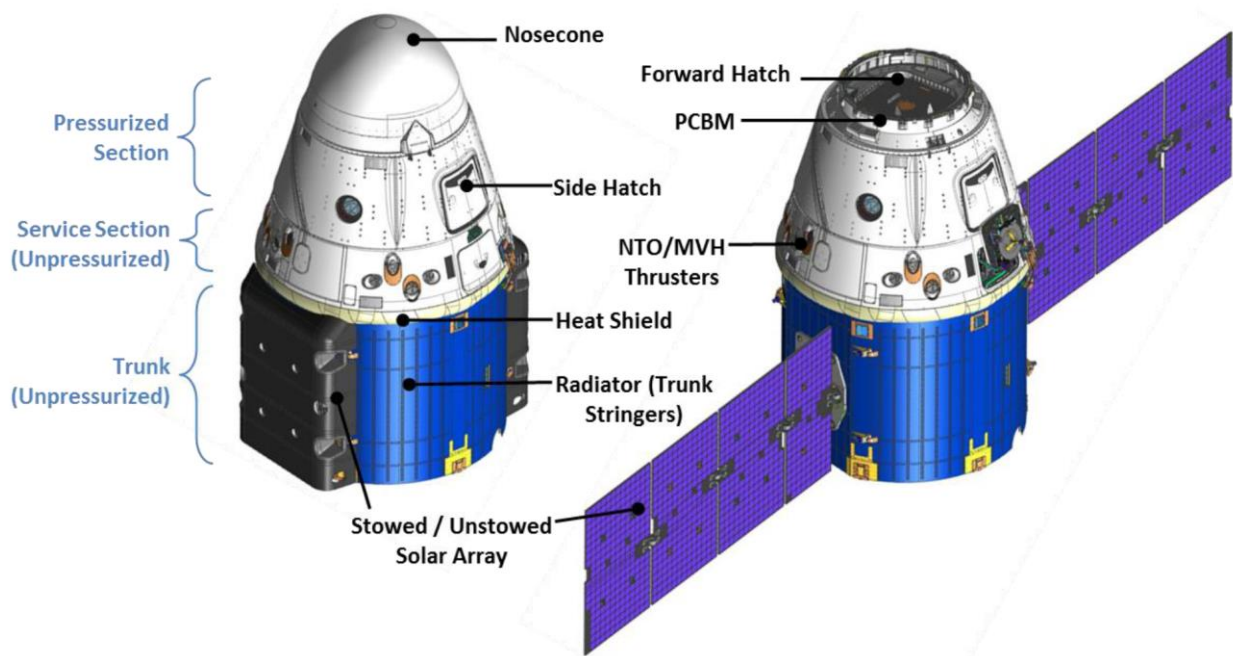
### 6.3.1 CARGO INTERFACE

Figure 6.3.1-1, Dragon Compartments, provides a quick look at the major components of the Dragon compartments.

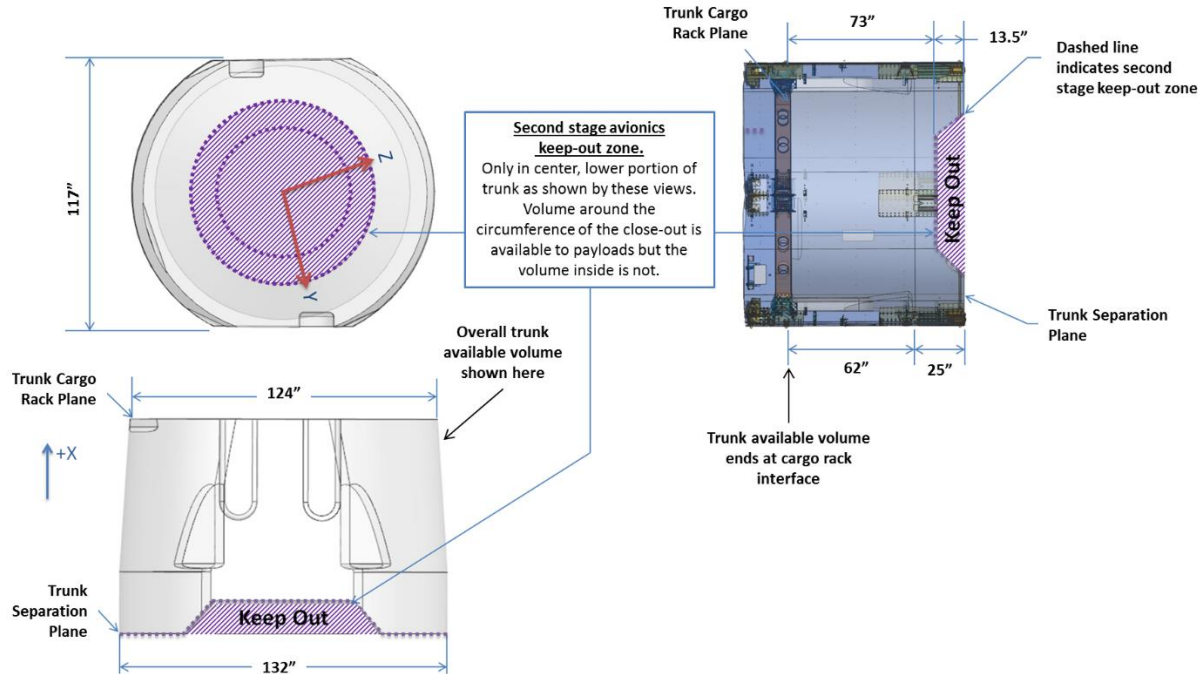
The types of Cargo interfaces to the Dragon include:

- (a) ExPA and CEPA payloads.  
Example: High Definition Earth Viewing, Optical Payload for Lasercomm Science. The Space Test Program – Houston 4 (STP-H4)
- (b) JEM-EF payloads (Direct Mount Cargo).  
Example: CATS.
- (c) Other direct mount unpressurized cargo (see Figure 6.3.1-2).  
Example: Bigelow Module

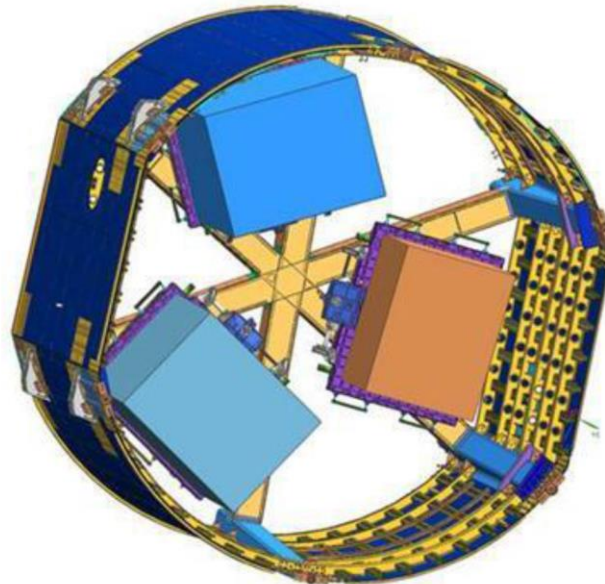
Figure 6.3.1-3, Three FRAM-Based Unpressurized Cargo Items, provides an illustration of three FRAM (ELC)-based payload items attached to Dragon external payload interface points.



**FIGURE 6.3.1-1 DRAGON COMPARTMENTS**



**FIGURE 6.3.1-2 DRAGON MAJOR COMPONENTS**



**FIGURE 6.3.1-3 THREE FRAM-BASED UNPRESSURIZED CARGO ITEMS**

### 6.3.2 POWER ACCOMMODATIONS

The Dragon visiting vehicle provides power accommodations in the trunk area of the visiting vehicle. This is where external payloads will be located. The power available, primarily for survival power, is up to 100 W continuous for all payloads at 120 V<sub>dc</sub> (+6/7 V) and 500-W peak at 28 V<sub>dc</sub>. This accommodation is defined in SSP 57012,<sup>48</sup> the Falcon 9 Launch Vehicle Payloads User Guide, Rev. 2, 2015<sup>52</sup> and applicable C3-1

Dragon Interface Definition Document Appendix: Dragon Cargo Flight Environments (only).<sup>53</sup>

Thermostats for power/payload heaters will only turn on when the temperature is below  $-30\text{ }^{\circ}\text{C}$  ( $-22\text{ }^{\circ}\text{F}$ ), based on accommodations defined in SSP 57012,<sup>48</sup> the Falcon 9 Launch Vehicle Payload Users Guide, Rev. 2, 2015<sup>52</sup> and applicable Dragon IDD.<sup>53</sup>

#### 6.4 ANALYTICAL DATA PRODUCTS

Range safety requirements are contained in the Range Safety Manual in the Air Force Manual 91-710, Range Safety User Requirements Manual.<sup>1</sup> In addition, the SpaceX safety process consists of (primarily) a “checklist,” which requires the PD to provide proof that safety requirements have been met. Although the SpaceX safety process is less rigorous than the ISS safety process some of the inputs used in the ISS safety process may also be used in the SpaceX process. However, the safety process for Falcon 9 launches is still evolving, so the PD should meet with their PIM and SpaceX personnel, as soon as the PD’s schedule allows to discuss more specific Falcon 9 safety information and requirements. Some additional information for safety requirements can also be found in Falcon 9 Launch Vehicle Payload User’s Guide, Rev. 2, 2015, Section 7.<sup>52</sup> In addition, the PD must develop a launch vehicle/visiting vehicle ICD with the launch services provider. In current cases, the ICD will be written between the PD and SpaceX. Specific, detailed interfaces will be contained within the Launch Vehicle ICD. At this time, the PDs should also continue to use SSP 57012,<sup>48</sup> for interface requirements to the launch vehicle/visiting vehicle.

#### 6.5 SPACEX PROVIDED HARDWARE

SpaceX provides specific hardware and equipment that is designed specifically for the payload-to-Dragon interface. This interface hardware includes:

- SpaceX Passive Flight Support Equipment (PFSE), including mounting attachments, serves as the interface between the payload and launch vehicle for JEM-EF payloads. This hardware is provided and installed by SpaceX at launch site.
- Zero Force Connector, which provides the electrical interface between the payload and launch vehicle for JEM-EF payloads. This connector provides payload heater power during launch and prior to robotic extraction from the Dragon capsule. In addition, an active connector is generally delivered to the PD for installation on their payload prior to delivery to the launch site, and is used to connect to the connector that is already contained within the Dragon capsule.
- The hardware that provides an attachment between the ExPA and CEPA structures is mounted into the Dragon capsule. This Dragon trunk-mounted cargo rack provides the primary mounting structure for the ExPA and CEPA payloads. These standard items are attached via FRAMs, and are released on-orbit using the robotics scenarios defined in Section 3.0. Refer to Figure 6.3.1-3.



## 7.0 FLIGHT AND GROUND SAFETY PROCESS

The single most important process that a PD will utilize and go through is the ISS Payloads Safety Review process. The Payloads Safety Review process combines both ground and flight safety reviews that ensures the safety for the human-rated ISS and the safety of ground support personnel, and equipment are fully complied with. This section outlines the ISS safety process, while Section 6.0, launch and visiting vehicles, describes the launch vehicle/visiting vehicle process for safety.

Once a PD starts the Payload Integration Process, the PD should request, through their PIM, an early safety assessment for their payload. Subsequent to that meeting, three required flight payload safety and one ground safety reviews will be scheduled for that payload. During the payload design/development process, the PD will be required to produce a Safety Data Package (SDP) by performing a safety analysis of their payload and GSE in parallel with their design review milestones. During the safety process, a Payload Safety Engineer (PSE) will be assigned to the payload that will assist the PD through the process.

The PD has two major safety elements that will require a substantial amount of resources. These elements are flight safety and ground safety. SSP 57061<sup>50</sup> provides additional primer information on the safety process.

### 7.1 ROLES AND RESPONSIBILITIES

The PD's key to the overall process is early contact with the ISS Payload Safety Review Panel (IPSRP) Executive Officers. Once a candidate payload is identified and requesting IPSRP review, a PSE is assigned, who will advise the PD through the entire safety process. The PD is responsible for completion of all SDP submittals, and providing verification that all safety data requirements have been met.

#### 7.1.1 FLIGHT SAFETY

The IPSRP is an ISS Safety Review Panel (SRP) located at JSC, and performs the following functions:

- Assist the PD in the interpretation of safety requirements.
- Conduct safety reviews during appropriate phases of the payload development.
- Evaluate hazard assessment revisions resulting from payload modifications that may affect a safety-critical subsystem or create potential hazards to the crew, ISS, or ISS visiting vehicles.
- Evaluate the safety analyses, safety reports, and waiver/deviation requests.
- Ensure the resolution of payload safety issues.

Although it is the responsibility of the IPSRP to audit the PD safety assessments, the PD is responsible for the safety of the payload for all mission phases. The PD is also responsible for not compromising the safety of other payloads, launch vehicle/visiting vehicle that are used to transport the payload, ISS transfer, and ISS operations.

### 7.1.2 GROUND SAFETY

The Ground Safety Review Panel (GSRP) is the ISS SRP located at KSC. The purpose of the GSRP is to ensure that all ground safety requirements are met and that all applicable ground requirements are met.

The GSRP process parallels that of the IPSRP and is described in NSTS/ISS 18798, Interpretation of NSTS/ISS Payload Safety Requirements.<sup>22</sup> The significant difference between the panels is that the GSRP generally only requires one safety review. The key to this process is early contact with the Lead Ground PSE for the flight assigned.

### 7.1.3 GROUND SAFETY AT INTERNATIONAL PARTNERS LAUNCH SITES

The process described in this section applies to processing at KSC only. If the payload is to be launched to the ISS from an International Partner Launch Site (French Guiana, Japan, Russia), compliance with those launch site's process is required. NASA will assist the PD in completing the appropriate process.

### 7.1.4 GROUND SAFETY AT NON-KSC U.S. LAUNCH SITES

For launch at non-KSC U.S. launch sites, the PD shall provide data to the launch vehicle/visiting vehicle provider. If the PD requires processing at a non-KSC launch site, NASA will assist in completing the appropriate process.

## 7.2 FLIGHT SAFETY

As pointed out in Paragraph 5.1.1, Integration Template, a PD will provide a flight SDP, with updates, at each of the following milestones:

- Concept design phase (Phase 0): PDs should include a Phase 0 safety review (hazard causes defined) in their payload's schedules. This Technical Interchange Meeting is completely optional. If a PD would like to have one, the assigned PSE will schedule it as requested, but it is left up to the PD to decide if it is desired.
- PDR (Phase I): PDs should complete the Phase I safety review activities (hazard causes refined and hazard controls defined with preliminary verifications). In many cases, Phase 0 and Phase I may be combined into a single package, due at PDR, based on specifics of the payload design. The Phase I review should be completed within 1 month of the instrument scheduled PDR.
- CDR (Phase II): PDs should complete the Phase II safety review to identify any design changes, new hazard causes and controls, and well-defined safety verification methods. The Phase II review should be completed within 1 month of the instrument scheduled CDR.
- 30 days prior to delivery (Phase III): The final flight safety review is called Phase III and must be completed 30 days prior to delivery of the payload, Airborne Support Equipment, and GSE to the launch site. The flight certificate of safety compliance shall be submitted at least 10 days prior to the Stage Operations Readiness Review. The Phase III review is focused on completion of hazard report safety verification method.

- Post Phase III Safety Review and Safety Verification Tracking Log: When the flight certification statement is submitted, it shall be included with an updated payload safety verification tracking log that documents the closeout of all required safety verification, and includes all post-Phase III safety activity.

Guidelines for the development of the critical Safety Packages can be found in JSC 26943, Guidelines for the Preparation of Flight Safety Data Packages and Hazard Reports.<sup>11</sup>

### 7.3 GROUND SAFETY

The PD's major effort for ground safety will be developing the Ground Safety Data Package. The GSRP recognizes that the initial submission may be difficult, but the PSE will work with the PD to correct any errors and missing information in order for the PD to complete the review process successfully.

The timing of ground safety review is critical to the start of ground operations. According to NSTS/ISS 13830, Rev. C, Payload Safety Review and Data Submittal Requirements,<sup>20</sup> submission of the SDP is due 45 days prior to the safety review. The safety review must be completed 30 days prior to the start of ground operations. This means that the package must be submitted 75 days prior to ground operations.

Additionally, the payload's flight safety reviews must be completed 30 days prior to the start of ground operations. Failure to do so will result in the delay of operations and possible launch date impact.

### 7.4 SAFETY DATA PACKAGES

The SDP contains two parts:

- Part one describes the payload, its systems, sub-systems, and interfaces, as well as flight and ground operations. It also summarizes hazard analyses used in the identification and control of payload hazards.
- Part two contains a series of hazard reports. The hazard report is used to summarize controls and verifications to ensure compliance to safety requirements. Elements of a hazard report include technical requirement references, description, and category of each hazard, and the hazard's cause, controls, and safety verification methods.

The primary objectives of the safety review process are to identify the potential payload hazards, including its flight, GSE, and ground operations, and to assure that the hazard controls and verifications (including on-orbit verification of hazard controls where applicable) comply with the safety requirements.

The following list provides examples of previously identified flight hazards:

- contamination,
- corrosion,
- electrical shock,
- explosion,
- fire,
- injury and illness,

- loss of vehicle capability, etc.

This list is NOT exhaustive, but provides a sense of the importance of flight safety.

The following are basic hazard groups applicable to ground operations:

- structural failure of support structures and handling equipment;
- collision during handling;
- inadvertent release of corrosive, toxic, flammable, or cryogenic fluids;
- inadvertent activation of ordnance devices;
- ignition of flammable atmosphere/material;
- electrical shock/burns;
- personnel exposure to excessive levels of ionizing or nonionizing radiation;
- use of hazardous GSE materials; etc.

In all cases, the PD should use established analytical techniques, such as preliminary hazard identification, sneak circuit, fault tree, operational hazard, and failure modes and effects analyses to obtain the data necessary to complete, present, and support payload hazard reports. The analysis is comprehensive and must consider hardware design, verification, testing, and flight/ground operations.

The PD's assigned PSE will assist throughout the development of the SDPs and corresponding analysis.

## 7.5 REQUIREMENTS

### 7.5.1 FLIGHT

The Payload Safety Process requirements are contained in NSTS/ISS 13830, Rev. C,<sup>20</sup> which further defines the deliverables and safety review activities, and provides excellent detailed information of developing your SDPs, and submittal requirements. The safety requirements are too numerous to be listed in their entirety, so more specific technical requirements for flight safety can be found in the following:

- NSTS 1700.7B, ISS Addendum, ISS Addendum, Safety Policy and Requirements for Payloads Using the ISS,<sup>21</sup>
- NSTS/ISS 18798, Interpretation of NSTS/ISS Payload safety Requirements,<sup>22</sup>
- SSP 50021, ISS Safety Requirements Document,<sup>37</sup>
- SSP 30599, Safety Review Process.<sup>34</sup>

NSTS 1700.7B, ISS Addendum,<sup>21</sup> contains the ISS payload safety technical requirements, and provides ISS references for the applicable core NSTS 1700.7B<sup>21</sup> requirements.

### 7.5.2 GROUND

KHB 1700.7, Space Shuttle – Payload Ground Safety Handbook (10 Aug 1999),<sup>12</sup> details the ground processing requirements for ISS payloads. There are two key data packages related to the ground safety process that must be completed by the PD. The first is the Ground Certificate of Safety Compliance, where the PDs certify that they are in compliance with the Ground Safety Requirements and the second is the Ground SDP, which provides the data supporting the certification.

Upon approval of the SDP and acceptance of the Certificate of Compliance, the GSRP will issue letters of approval for the start of operations. Sometimes, at this point, the PD will have a Safety Verification Tracking Log (VTL) with open items that are constraints to ground operations. The PD needs to work closely with the PSE to ensure the proper operations are constrained and that the items are closed in a timely manner.

## 7.6 SAFETY IDENTIFICATION AND ANALYSIS

The PD is responsible for performing safety analysis for each payload, its GSE, related software, and ground and flight operations to identify hazardous subsystems and functions. A safety assessment report documents the results of this analysis, including hazard identification, classification, resolution, and a record of all safety-related failures. This report shall be prepared, maintained, and submitted in support of the safety assessment reviews.

Hazards are classified as either critical or catastrophic:

- Critical hazards can result in damage to ISS equipment, or a non-disabling personnel injury.
- Catastrophic hazards can result in the potential for a disabling or fatal personnel injury, loss of the ISS, ground facilities, or equipment.

Fault tolerance may also be a cost driver for the PD. It should be noted that catastrophic hazard mitigation requires 2-fault tolerance for the system, subsystem, or elements identified as such. In all cases, the PD's major goal throughout the design phase shall be to ensure safety through the selection of appropriate design features. Damage control, containment, and isolation of potential hazards shall be included in design considerations.

Actions for reducing hazards should be conducted in the following order of precedence:

- Design for Minimum Hazard – The PD should develop appropriate design features, including damage control, containment, and isolation of potential hazards.
- Safety Devices – Hazards that cannot be eliminated through design shall be made controllable through the use of automatic safety devices as part of the system, subsystem, or equipment.
- Warning Devices – When it is not practical to preclude the existence or occurrence of known hazards or to use automatic safety devices, devices shall be employed for the timely detection of the condition and the generation of an adequate warning signal, coupled with emergency controls of corrective action for operating personnel to safe or shut down the affected subsystem. Warning signals and their application shall be designed to minimize the probability of wrong signals or of improper reaction to the signal.
- Special Procedures – Where it is not possible to reduce the magnitude of a hazard through design or the use of safety and warning devices, special procedures shall be developed to counter hazardous conditions for enhancement of personnel safety.

It must be stressed that designing for hazard elimination or reduction is the preferred method, by far, of hazard mitigation.

### **7.7 SUMMARY**

The PD should always have the safety process foremost in their minds and in their designs for the payload, ground equipment, airborne support equipment, etc. The safety process is rigorous and necessary, and no payload will be flown until ALL safety requirements, data submittals, and certification has been completed and approved by the respective safety boards.

## 8.0 ISS PROGRAM-PROVIDED HARDWARE

### 8.1 ISS-PROVIDED HARDWARE

The ISS Program provides accommodation hardware to PDs for attaching and interfacing to the ISS.

The ISS payload adapters and interface units are GFE and are part of the standard services provided by ISS, and are generally provided to the PD at no cost.

These include:

- ExPA for flight on the ISS truss (ELC), including the FRAM
- CEPA – similar to the ExPA
- PIU for flight on JEM-EF

Table 8.1-1, ISS Hardware Available as GFE, provides a comprehensive list of ISS-provided hardware.

Additional hardware MAY be available, but must be negotiated with the ISS Program.

**TABLE 8.1-1 ISS HARDWARE AVAILABLE AS GFE**

FRAM Fit-Check Plate	Payload Interface Unit (PIU) (JEM-EF)
ExPA – GOLD (Limited, subject to availability)	CEPA J5 28 VDC
ExPA – latest revision	CEPA J7 APM P/L Bus
FRAM Horizontal EVA Handrails	CEPA J8 USL P/L Bus
FRAM Rear EVA Handrails	CEPA J9 APM LAN/HRD
FRAM Front Horizontal EVA Handrails	CEPA J10 USL LAN
FRAM Vertical EVA Handrails	CEPA J11 P/L CMD/MON
CEPA – GOLD (limited, subject to availability)	CEPA J12 P/L CMD/MON
CEPA – latest revision	ExPA J1 120 VDC Connector
Flight Releasable Grapple Fixture	ExPA J3 120 VDC Contingency Power Connector
Flight Releasable Grapple Fixture GSE Drill Template	ExPA J4 28 VDC Heater Power Connector
Dextre H-Fixture Kit	ExPA J5 28 VDC Operational Power Connector
Micro Square Fixture	ExPA J7 Payload 1553 & Ethernet Connector
Micro Conical Fitting	ExPA J8 1553 RT2/Ethernet Interface 2
Modified Truncated Cone Target	ExPA J9 Analog Signal Connector
CEPA J1 120 VDC	ExPA J10 Analog Signal Connector
CEPA J2 120 VDC	ExPA J11 Discrete Signal Connector
CEPA J3 120 VDC	ExPA J12 Discrete Signal Connector
CEPA J4 28 VDC	

### 8.2 ISS-PROVIDED SIMULATORS

To assist in the development of the payload, the ISS Program can provide small test equipment that emulates the ISS side of the interface, specifically for payload

development. These systems are portable and can be shipped to the PD's location. These systems are referred to as the Suitcase Test Environment for Payloads (STEP) and may be shipped to the PDs facility (see Figure 8.2-1, Portable Test Environment for Development and Testing of ELC Payloads and Figure 8.2-2, ELC Suitcase Simulator). The STEPs are generally utilized at no cost to the PD.



**FIGURE 8.2-1 PORTABLE TEST ENVIRONMENT FOR DEVELOPMENT AND TESTING OF ELC PAYLOADS**



**FIGURE 8.2-2 ELC SUITCASE SIMULATOR**

An ELC Functional Equivalent Unit is a rack-mounted, high-fidelity functional unit of the ELC, and is located at MSFC. It is used by the Payload Software Integration Test Facility to verify ELC flight software and payloads during the verification phase of your project schedule. It may be used at no cost to the PD.



The ELC Simulator simulates the ELC interfaces and is located at KSC (see Figure 8.2-3, ELC Simulator). This unit is used for final verification of a payload's C&DH and power to the ISS. The ELC is used at no cost to the PD, and is operated primarily by ISS personnel.



**FIGURE 8.2-3 ELC SIMULATOR**

### **8.3 INTERNATIONAL PARTNER FACILITIES**

Columbus payloads MAY elect to be tested using the standard U.S. facilities or the Rack Level Test Facility in Bremen Germany. However, the Rack Level Test Facility will not generally be used by NASA PDs.

JEM-EF payloads are tested using the standard U.S. facilities or at the JAXA launch facility in Tanegashima, Japan. As is the case with Columbus payloads, the JAXA facility will not generally be used by NASA PDs.

In addition, various commercial options are available or in development for use in place of the ELC STEP (suitcase simulators). The Boeing Company has also developed a software simulator known as Remote Advanced Payload Test Rig, which is available for use by PDs.

### **8.4 SUMMARY**

When ISS test facilities or capabilities are requested, approval and scheduling the use of these valuable assets must be negotiated with your assigned PIM.

All in all, the ISS Program now provides excellent interfacing tools, hardware, and software simulators, and on-orbit interfacing equipment that will prove to be invaluable in your payload life cycle. Consider the use of these valuable tools during your payload's schedule of events, both during development and verification.

## 9.0 PAYLOAD DEVELOPER-PROVIDED HARDWARE

Items typically the responsibility of the PDs are items that are generally considered unique to the payload and are not included in either the ISS standard or coordinated services outlined in Section 8.0, ISS Program-Provided Hardware. These items are generally the responsibility of the PDs to provide, and examples are outlined below.

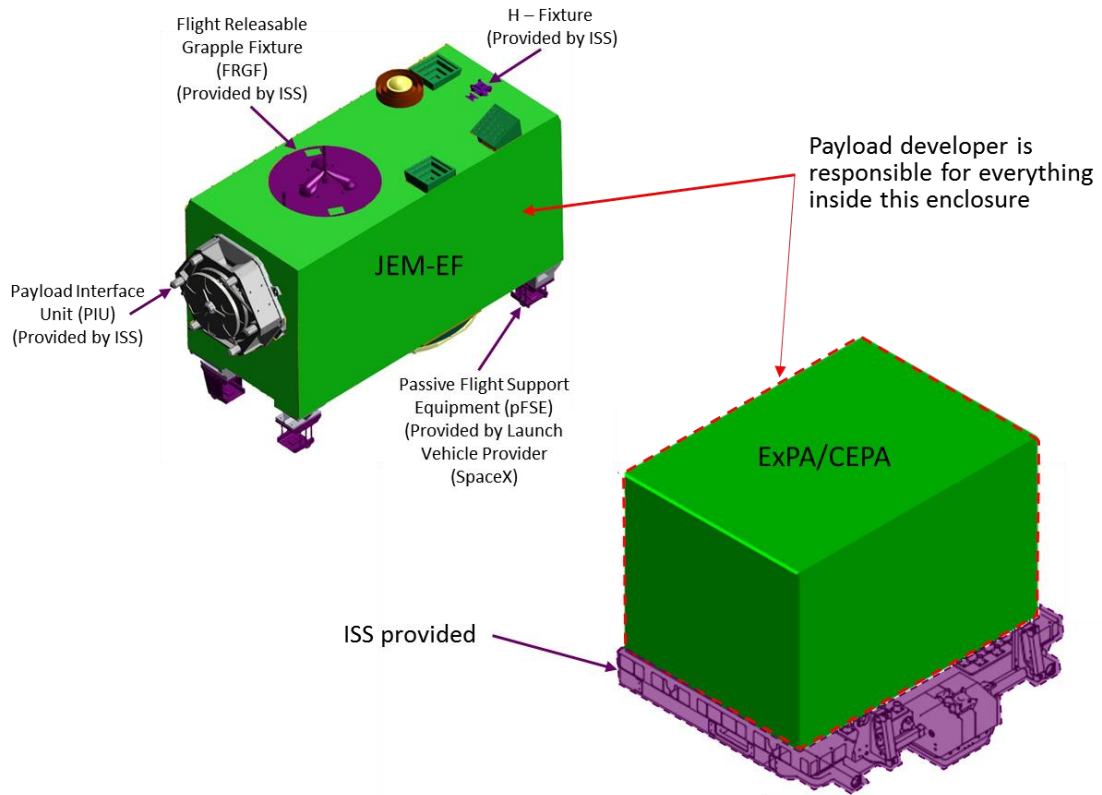
Typical PD-funded Items for ISS interfacing include:

- Simple attach plates, and fasteners, connecting a payload to the ExPA or CEPA
- Hardware that attaches the payload to fluid lines and power connections from the JEM-EF PIU, including payload-internal plumbing, valves, quick/disconnects, and other connections on the payload-side of the PIU interface (the PD must procure the electrical, mechanical, fluid loop connectors on their side of the interface)
- Test plates and test platforms, such as an ELC used for payload testing, etc. (ISS provides flight-unit ELC, PIUs, and CEPAs only)
- JEM-EF platform or “box” containing the experiment, the ISS funded PIU, and attachment mechanisms/feet, grapple fixture, etc. included
- Electrical connectors that attach to the ISS-provided halves of ELC, CEPA, and JEM-EF connections
- JEM-EF attachment test unit
- Payload shipping containers
- Blankets (thermal)
- Battery charging equipment
- Payload processing in other than SSPF, or international partner facilities, to accommodate payload requirements that cannot be met at the Space Station Processing Area
- Specific requirements for environmental and/or contamination control that are non-standard for each of the KSC processing facilities
- Large quantities of consumables (i.e., gaseous nitrogen)
- On-orbit recording capability – data latency capability – with subsequent downlink, if required beyond that of ISS-provided services

This list is not exhaustive, and should be used for initial planning purposes only as a rule of thumb. As your payload design and development matures, coordination with your PIM is essential. During this process, the details of what you may require outside of ISS-provided hardware, and the example items list above, will become more focused.

The “typical” hardware listed above may vary widely in costs. However, the fluid connections, on the payload side of the JEM-EF interface, could be substantial. These items should be carefully evaluated and included in your proposal.

Figure 9.0-1, PD-Provided Hardware Interface Plane, graphically depicts the interface plane between the ISS-provided hardware and the PD-supplied hardware.



**FIGURE 9.0-1 PD-PROVIDED HARDWARE INTERFACE PLANE**

## 10.0 ACRONYMS/ABBREVIATIONS

AFRAM	Active Flight Releasable Attach Mechanism
AO	Announcement of Opportunity
AP	Access Points
API	Advanced Publication Information
APM	Attached Pressurized Module
APS	Automated Payload Switch
ATCS	Active Thermal Control System
BAD	Broadcast Ancillary Data
BC	Bus Controller
BFC	Broadcast Frame Count
C&C	Command and Control
C&DH	Command and Data Handling
C&T	Command and Telemetry
C.G.	Center of Gravity
CAD	Computer Aided Design
CATS	Cloud-Aerosol Transport System
CBE	Current Best Estimate
CCSDS	Consultative Committee for Space Data Systems
CDR	Critical Design Review
CEPA	Columbus External Payload Adapter
CEPF	Columbus External Payload Facility
CLA	Camera/Light Assembly
CLPA	Camera/Light/Pan-Tilt Assembly
CMG	Control Moment Gyroscopes
CoFR	Certificate of Flight Readiness
Columbus-EPF	Columbus-External Payload Facility
CRS	Commercial Resupply Services
CSA	Canadian Space Agency
CST	Customer Service Team
CTRS	Conventional Terrestrial Reference System
CV	Continuous Vulcanizing
DMC	Data Management Coordinator
DMS	Data Management System
ECR	Engineering Change Request
EEU	Equipment Exchange Unit
EF	Exposed Facility
EFU	Exposed Facility Unit
EIRP	Equivalent Isotropically Radiated Power
ELC	ExPRESS Logistics Carrier
ELM	Experiment Logistics Module
EMC	Electro-magnetic Compatibility
EMI	Electro-magnetic Interference
EMR	Electro-magnetic Radiation

EOTP	Enhanced ORU Temporary Platform
EP	Exposed Pallet - Multi-Purpose
EPF	External Payload Facility
EPMP	Environmental Protection and Management Plan
ESA	European Space Agency
ESD	Electrostatic Discharge
ESMP	Earth Systematic Missions Program
ESP	External Stowage Platform
ESSP	Earth Science Systematic Program
EV	Earth Venture
EVA	Extravehicular Activity
EVR	Extravehicular Robotics
EWC	External Wireless Communication
ExPA	ExPRESS Payload Adapter
ExPCA	ExPRESS Pallet Control Assembly
ExPRESS	Expedite the Processing of Experiments to the Space Station
FCT	Flight Control Team
FGB	Functional Cargo Block
FOD	Flight Operations Directorate
FOV	Field of View
FP	Floating Potential
FRAM	Flight Releasable Attach Mechanism
FRGF	Flight Releasable Grapple Fixture
FRR	Flight Readiness Review
FSE	Flight Support Equipment
GCP	Ground Command Procedures
GDS	Ground Data Services
GF	Grapple Fixture
GFE	Government Furnished Equipment
GN&C	Guidance, Navigation and Control
GPS	Global Positioning System
Gr&C	Ground Rules and Constraints
GSE	Ground Support Equipment
GSFC	Goddard Space Flight Center
GSRP	Ground Safety Review Panel
H&S	Health and Safety
HOSC	Huntsville Operations Support Center
HPEG	HOSC Payload Ethernet Gate
HRDL	High-Rate Data Link
ICD	Interface Control Document
ICS	Inter-Orbit Communication System
IDD	Interface Definition Document
IEEE	Institute of Electrical and Electronics Engineers
INS	Inertial Navigation System
IP	International Partner
IPSRP	ISS Payload Safety Review Panel

IRD	Interface Requirements Document
ISPR	International Standard Payload Rack
ISS	International Space Station
ITA	Integrated Truss Assembly
ITS	Integrated Truss Segment
JAXA	Japan Aerospace Exploration Agency
JEM-EF	Japanese Experiment Module-Exposed Facility
JEM-PM	Japanese Experiment Module-Pressurized Module
JEM-RMS	Japanese Experiment Module-Remote Manipulator System
JSC	Johnson Space Center
JSL	Joint Station Local Area Network
KSC	Kennedy Space Center
L	Launch
LAN	Local Area Network
LaRC	Langley Research Center
LEE	Latching End Effector
LEHX	Layer 2 Ethernet Switch and Multiplexer
LIS	Lead Increment Scientist
LEO	Low Earth Orbit
LOS	Loss of Signal
LP	Linear Polarization
LRDL	Low-Rate Data Link
LTA	Launch-To-Activation
LVLH	Local Vertical Local Horizontal
MA	Main Arm
MAGIK	Manipulator Analysis Graphics and Interactive Kinematics
MBS	Mobile Base System
MCC-H	Mission Control Center – Houston
MCF	Micro-Conical Fitting
MDM	Multiplexer/Demultiplexer
MDP	Maximum Design Pressures
MEDIC	MSFC Electromagnetic Compatibility Design and Interference Control
MEV	Maximum Expected Value
MIMO	Multiple-Input and Multiple-Output
MISSE	Materials International Space Station Experiment
MLI	Multi-Layer Insulation
MM	Momentum Manager
MRDL	Medium Rate Data Link
MSFC	Marshall Space Flight Center
MSS	Mobile Servicing System
MTC	Modified Truncated Cone
OLR	Outgoing Long-Wave Radiation
OPT	ORU Temporary Platform
ORU	Orbital Replacement Units
OTCM	ORU/Tool Change Out Mechanism

OTVC	Optical Thermal Vacuum Chamber
OZ	ISS Research Office
P/L	Payload
P/N	Part Number
PCS	Personal Computer System
PD	Payload Developer
PDGF	Power and Data Grapple Fixture
PDL	Payload Data Library
PD-POC	Payload Developer Payload Operations Center
PDR	Preliminary Design Review
PEHG	Payload Ethernet Hub Gateway
PFRAM	Passive Flight Releasable Attach Mechanism
PFSE	Passive Flight Support Equipment
PIA	Payload Interface Agreement
PIM	Payload Integration Manager
PIU	Payload Interface Unit
PM	Pressurized Module
POC	Payload Operations Center
POIC	Payload Operations and Integration Center
POIF	Payload Operations Integration Function
PPF	Payload Processing Facility
PPM	Payload Planning Manager
PRCU	Payload Rack Checkout Unit
PSE	Payload Safety Engineer
PSRP	Payload Safety Review Panel
PTCS	Passive Thermal Control System
PUI	Payload Unique Identifiers
PVGF	Power and Video Grapple Fixture
RF	Radio Frequency
RHCP	Right-Hand-Circular Polarization
RIO	Research Integration Office
RMCT	Robot Micro-Conical Tool
RMS	Remote Manipulator System
RNP	Rotation, Nutation and Precession
ROST	Robotic Offset Tool
Roscosmos	State Space Corporation
RPWG	Research Plan Working Group
RS	Radiated Susceptibility
RT	Remote Terminal
RTV	Room-Temperature Vulcanizing
SARJ	Solar Alpha Rotary Joint
SDN	Starboard Deck Nadir
SDP	Safety Data Package
SDX	Starboard Deck X-Direction
SET	Socket Extension Tool
SFA	Small Fine Arm

SIGI	Spacecraft Integrated GPS/Inertial Navigation System (INS)
SOX	Starboard Overhead X-Direction
SOZ	Starboard Overhead Zenith
SPDM	Special Purpose Dexterous Manipulator
SRP	Safety Review Panel
SSPF	Space Station Processing Facility
SSRMS	Space Station Remote Manipulator System
STEP	Suitcase Test Environment for Payloads
STP	Space Test Program
TBS	To Be Supplied
TCP	Transmission Control Protocol
TDRSS	Tracking and Data Relay Satellite System
TEA	Torque Equilibrium Attitude
THA	Tool Holder Assembly
TQCM	Thermally controlled Quartz Crystal Microbalances
U.S.	United States
USB	Universal Serial Bus
USL	United States Laboratory
UTC	Universal Time Coordinated
VLAN	Virtual Local Area Network
VTL	Verification Tracking Log
WAP	Wireless Application Protocol
WSC	White Sands Complex
XCMU	External Command and Monitoring Unit



## 11.0 REFERENCE

- |    |   |  |
|----|---|--|
| 1  | AFSPCMAN 91-710   | Range Safety User Requirements Manual  |
| 2  | ASTM E1559  | Standard Test Method for Contamination Outgassing Characteristics of Spacecraft Materials  |
| 3  | CLT-TN-AI-0038,<br>Issue 6, 24.05.2005<br>(R.D. 2.2.10) | APM Simplified Thermal Mathematical Model<br>Description for ISSA/APM/I/F Thermal Analysis   |
| 4  | COL-RIBRE-SPE-<br>0165                                  | Columbus External Payloads Interface Requirements Document   |
| 5  | COL-RIBRE-SPE-<br>0165-1C                               | ISS TMM for external P/L mounted on the Columbus External Payload Facility (CEPF),   |
| 6  | D683-97477-01<br>Revision D                             | Columbus External Payload Adapter (CEPA) Assembly Interface Definition Document (IDD)  |
| 7  | D683-97497-01<br>Revision E                             | ExPRESS Payload Adapter (ExPA) Interface Definition Document (IDD)   |
| 8  | D684-10058-03-02,<br>October 31, 1999                   | Integrated ISS Thermal Math Models Volume 3, Book 2 International Space Station Program, Boeing/ NASA, JSC (R.D. 2.2.9)  |
| 9  | D684-14957-01,<br>2015                                  | External Wireless Communications User Guide  |
| 10 | JFX-2000073   | The Exposed Facility Payload Thermal Math Model Requirements for JEM Element Integration Thermal Analysis  |
| 11 | JSC 26943   | Guidelines for the Preparation of Flight Safety Data Packages and Hazard Reports   |
| 12 | KHB 1700.7C,<br>August 10, 1999                         | Space Shuttle - Payload Ground Safety Handbook   |
| 13 | KPLHB 50001   | Launch Site Accommodations Handbook for Payloads   |
| 14 | MIL-STD-1553B   | Digital Time Division Command/Response Multiplex Data Bus, <a href="https://assist.dla.mil/online/start/">https://assist.dla.mil/online/start/</a>                   |
| 15 | NASA Reference<br>Publication 1368                      | Marshall Space Flight Center Electromagnetic Compatibility Design and Interference Control (MEDIC) Handbook, <a href="http://ntrs.nasa.gov">http://ntrs.nasa.gov</a> |
| 16 | NASDA-ESPC-2563   | JPAH Vol. 3, Exposed Facility/Payload Standard Interface Control Document  |
| 17 | NASDA-ESPC-2900A  | JEM Payload Accommodations Handbook Vol. 3 Exposed Facility Payload Standard Interface Control Document  |
| 18 | NASDA-ESPC-2901   | JPAH Vol.4: JEM Manipulator / Payload Interface Control Document   |
| 19 | NASDA-ESPC-3122   | Payload Interface Unit Product Specification   |
| 20 | NSTS/ISS 13830<br>Revision C,<br>July 13, 1998          | Payload Safety Review and Data Submittal Requirements  |

21	NSTS 1700.7B	International Space Station (ISS) Addendum, "Safety Policy and Requirements for Payloads Using the ISS,"
22	NSTS/ISS 18798	Interpretation of NSTS/ISS Payload safety Requirements
23	OZ-10-056	Payload Developers and Principal Investigators Payload Planning, Integration and Operations Primer
24	POIF-1004	Payload Operations Handbook, Volume 1
25	SSP 30219 2008	Space Station Reference Coordinate Systems
26	SSP 30237	Space Station Electromagnetic Emission and Susceptibility Requirements
27	SSP 30240	Space Station Grounding Requirements
28	SSP 30242	Space Station Cable/Wire Design and Control Requirements for Electromagnetic Compatibility
29	SSP 30243	Space Station Requirements for Electromagnetic Compatibility
30	SSP 30245	Space Station Electrical Bonding Requirements
31	SSP 30425	Space Station Program Natural Environment Definition For Design - International Space Station Alpha
32	SSP 30426 Revision D	Space Station External Contamination Control Requirements
33	SSP 30573	Space Station Program Fluid Procurement and Use Control Specification
34	SSP 30599	Safety Review Process
35	SSP 41000	System Specification for the International Space Station
36	SSP 41175-02, 2004	Software Interface Control Document (ICD) Station Management and Control to International Space Station, Book 2, General Software Interface Requirements
37	SSP 50021	ISS Safety Requirements Document,
38	SSP 50304 Baseline, May 1, 1998	Payload Operations and Integration Center (POIC) Capabilities Document
39	SSP 50423	ISS Radio Frequency Coordination Manual
40	SSP 50540	Software Interface Definition Document Broadcast Ancillary Data
41	SSP 51700	Payload Safety Policy and Requirements for the International Space Station
42	SSP 52050 Rev. K	International Standard Payload Rack to International Space Station, Software Interface Control Document Part 1
43	SSP 57003	Attached Payload Interface Requirements Document
44	SSP 57003-ELC	Attached Payload Interface Requirements Document - Expedite The Processing of Experiments to Space

	Station (Express) Logistics Carrier (ELC) Cargo Interface Requirements
45	SSP 57004 Attached Payload Hardware Interface Control Document Template
46	SSP 57004-ELC Attached Payload Interface Control Document Express Logistics Carrier (ELC) Cargo Interface Control Document Template
47	SSP 57011 Payload Verification Program Plan
48	SSP 57012 ISS FRAM Based Payload Common Launch Interface Requirement Document (IRD)
49	SSP 57021 Rev. A, September 2002 Attached Payloads Accommodation Handbook
50	SSP 57061 Standard Payload Integration Agreement for ISS External Payloads
51	SSP 58311 Payload Operations Integration Center Payload Operations Handbook Volume 1: Pre-/Post-Increment Operations
52	No number Falcon 9 Launch Vehicle PAYLOAD USER'S GUIDE, Rev. 2, 2015
53	SpX-00001047 C3-1 Dragon Interface Definition Document Appendix: Dragon Cargo Flight Environments (only)

**Points of Contact:**

\*Lowell Primm  
GSFC/Earth Systematic Missions Program Office  
Greenbelt, Md. 20771  
(301) 286-7124  
[Lowell.E.Primm@nasa.gov](mailto:Lowell.E.Primm@nasa.gov)

Kenol Jules  
ISS External Payloads Portfolio Manager  
ISS Research Integration Office  
NASA Johnson Space Center  
Houston, TX 77058  
Phone: (281) 244-5516  
[Kenol.Jules-1@nasa.gov](mailto:Kenol.Jules-1@nasa.gov)

\*Contributor to the development of this document.